

MAT 126

Final Exam

December 14, 2016

Name: _____ ID: _____ Rec: _____

Question:	1	2	3	4	5	6	7	8*	9*	10*	11*	12*	Total
Points:	10	10	10	15	15	20	20	20	20	20	20	20	180
Score:													

There are 12 problems on 10 pages in this exam. Make sure that you have them all.

Note that you should **cross out one of problems 8–12**, and not do it.

Do all of your work in this exam booklet, and cross out any work that the grader should ignore. You may use the backs of pages, but indicate what is where if you expect someone to look at it. If you read these instructions, write the phrase pi is yummy at the bottom of this page and I will give you 2 points of extra credit on the exam. **Books, calculators, extra papers, and discussions with friends are not permitted. No electronic devices may be used AT ALL.** Since we studied complex numbers, conferring with imaginary friends is allowed, provided you do so quietly. Conferring with enemies (real or imaginary) is not recommended (nor is it permitted).

Points will be taken off for writing mathematically false statements, even if the rest of the problem is correct.

Leave all answers in exact form (that is, do *not* approximate π , square roots, and so on.)

You might find it helpful to remember the following:

$$\begin{aligned} \sin^2 \theta + \cos^2 \theta &= 1 & \tan^2 \theta + 1 &= \sec^2 \theta \\ \sin^2 \theta &= \frac{1}{2}(1 - \cos(2\theta)) & \cos^2 \theta &= \frac{1}{2}(1 + \cos(2\theta)) \\ \sin(2\theta) &= 2 \cos \theta \sin \theta & \cos(2\theta) &= \cos^2 \theta - \sin^2 \theta \\ e^{i\theta} &= \cos \theta + i \sin \theta & e^{i\pi} + 1 &= 0 \end{aligned}$$

Or maybe not. Who can tell?

You have 2 hours and 30 minutes to complete this exam.

Name: _____

Id: _____

10 pts

1. Calculate the integral $\int_{-1}^1 x^3 + 3x^2 - \frac{1}{1+x^2} dx$.

If the integral is improper and it does not converge, write "Diverges" (and justify).

10 pts

2. Calculate the indefinite integral $\int we^{2w} dw$.

10 pts

3. Calculate the integral $\int_1^{\infty} \frac{du}{(2u-1)^2}$.

If the integral is improper and it does not converge, write "Diverges" (and justify).

Name: _____

Id: _____

15 pts 4. Calculate the indefinite integral $\int \frac{3dx}{(2x+1)(x-1)}$.

15 pts 5. Calculate the indefinite integral $\int \sin^4(2t) \cos^3(2t) dt$

Name: _____

Id: _____

6. The function $f(x)$ has the graph shown at right, for $-5 \leq x \leq 3$.

Define another function $g(x)$ by

$$g(x) = \int_{-5}^x f(t) dt.$$

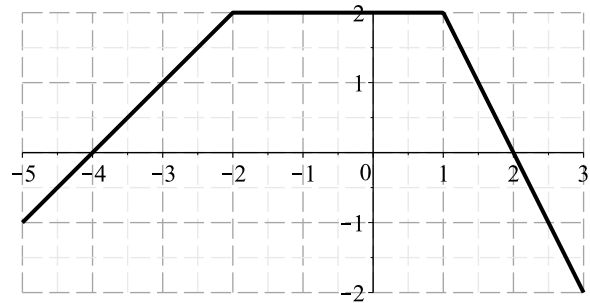

5 pts

- (a) For what x does $g(x)$ take on its maximum value for $-5 \leq x \leq 3$?
(If there is no maximum, write "None"; if there are several such x , list them all.)

5 pts

- (b) What is $g(2)$? (If it is not defined, write "DNE".)

5 pts

- (c) What is the minimum value of $g(x)$ for $-5 \leq x \leq 3$?
(If there is no minimum, write "None".)

5 pts

- (d) What is the largest interval (for x between -5 and 3) on which $g(x)$ is concave down?
(If there is no such interval, write "None".)

Name: _____

Id: _____

20 pts

7. Consider the region lying above the graph of $y = x$, below the graph of $y = 2x \cos(x)$, to the right of $x = 0$, and to the left of $x = \frac{\pi}{2}$. See the figure at right (note that the region does not contain all x values between 0 and $\frac{\pi}{2}$).

Find the area of this region.

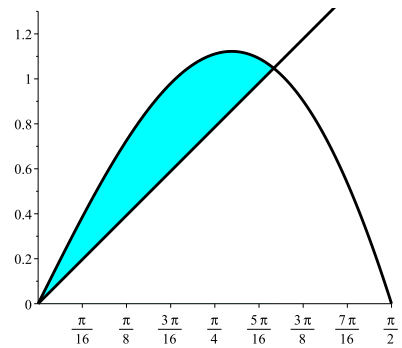

Name: _____

Id: _____

Do **any four** of the five questions 8-12. Cross out the one you don't want graded.

20 pts

8. A bottle 12 inches high has its radius r (in inches) at height h recorded in the table at right. **Use Simpson's rule to estimate the volume of the bottle.**

(If you don't remember Simpson's rule, you may use the Trapezoid rule instead, but you will get a maximum of 15 points. Or, use left or right endpoints for half credit. **Clearly indicate which method you are using!**)

Hint: First write an integral representing the volume in terms of some function $r(h)$, then use Simpson's rule to approximate it.

h	0	3	6	9	12
r	2	3	3	2	1



Name: _____

Id: _____

Do **any four** of the five questions 8-12. Cross out the one you don't want graded.

10 pts

9. (a) Write an integral that represents the arc length of the graph of $y = 2x + \frac{x^3}{3}$ for $0 \leq x \leq 3$. **You do not need to calculate the value of the integral!**

10 pts

- (b) Find the average value of the function $f(x) = x^2 \sin(2x)$ over the domain $0 \leq x \leq \frac{\pi}{2}$.

Do **any four** of the five questions 8-12. Cross out the one you don't want graded.

20 pts

10. Fireman Fred has an underground tank partially full of Fluorotelomer Fire-Fighting Foam.

The tank is conical, with the vertex at the top of the tank. The height of the tank is 12 feet, with a diameter of 8 feet, and is filled to a height of 9 feet. Fred wants to pump the foam out of the tank and into his truck, which fills at a height 5 feet above ground level. The foam has a density of 4 pounds per cubic foot and has a delightful minty scent.

Write an integral which represents the amount of work (in foot-pounds) required for Fred to pump all of the foam out of the tank and into his truck. (You do not need to calculate the integral).

Since the weight of the foam is given (in pounds) instead of the mass, you should **not** include g , the acceleration due to gravity.

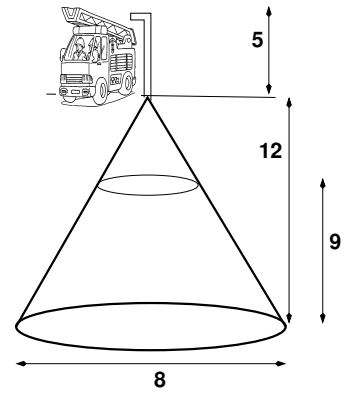

This problem requires material we didn't cover in this class. We will have different applications.

Name: _____

Id: _____

Do **any four** of the five questions 8-12. Cross out the one you don't want graded.

20 pts

11. Find the area of the region that lies inside the circle of radius one centered at $(1, 0)$, but outside the circle of radius one centered at the origin.

You can do this either in polar coordinates (where the two curves are given by $r = 2 \cos \theta$ and $r = 1$) or in rectangular coordinates (where the curves are given by $(x - 1)^2 + y^2 = 1$ and $x^2 + y^2 = 1$). In the rectangular case, you need to cut up the area appropriately.

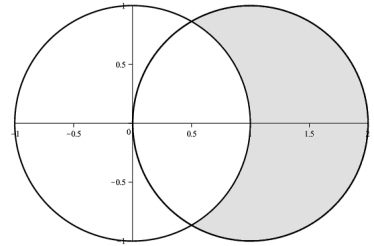

Name: _____

Id: _____

Do **any four** of the five questions 8-12. Cross out the one you don't want graded.

12. Wind speed can be modeled by the Rayleigh distribution $f(x) = \begin{cases} \frac{x}{\sigma^2} e^{-\frac{x^2}{2\sigma^2}}, & \text{for } x \geq 0 \\ 0 & \text{for } x < 0 \end{cases}$, where σ is the most common wind speed (the mode).

10 pts

- (a) If the most common wind speed is a breeze of 5 knots, what is the probability that the wind speed will be more than 20 knots? Do not approximate e , logs, or square roots.

10 pts

- (b) Again assuming $\sigma = 5$, calculate the median¹ wind speed. Do not give an approximation.

¹Recall that the **median** of a probability density function $f(x)$ is the number m so that the probability that $x \geq m$ is $\frac{1}{2}$ (and so also the probability that $x < m$ is $\frac{1}{2}$).

Name: _____

Id: _____

Once this page was blank, and once it was a tree. You can make it less blank if you find that useful. Turning it back into a tree is also worthwhile, but more effort.