

PRINT your Name:

problem	1	2	3	4	5	6	7	8	Total
possible	20	20	25	20	25	20	25	20	175
score									

Directions: There are 8 problems on 8 pages in this exam (printed on both sides). Do all of your work in this exam booklet, and cross out any work that should be ignored. You may not use any books, extra papers, or discussions with friends during this exam. You are welcome to use a calculator.

Reading the mind of the professor or the TAs is also permitted, although we'd appreciate it if you would stick to the areas of our brains concerned with mathematics, and leave our personal thoughts alone. Thanks.

1. (20 points) In playing the game of "Go Fish", players are dealt hands of 7 cards from a standard deck of 52, and try to make pairs (two cards with the same number). What is the probability that a player will be dealt at least one pair in his hand at the start of the game? (Circle your answer, no justification needed).

$$1 - \frac{52!}{7! 45!} = 1 - \frac{52 \times 48 \times 44 \times 40 \times 36 \times 32 \times 28}{52 \times 51 \times 50 \times 49 \times 48 \times 47 \times 46} = \frac{(52C2)(52C5)}{52C7}$$

$$1 - \frac{7!}{52!} = \frac{7! 2!}{52 \times 51 \times 50 \times 49 \times 48 \times 47 \times 46} = 0.47172816$$

2. (20 points) Circle True or False. No justification needed, but then, no partial credit either.

a. For any connected graph, a minimal spanning tree can be found using Prim's nearest-neighbor algorithm.

True False

b. If you roll two dice, then the probability that at least one of them is a 6 is 1/3.

True False

c. Some zero-sum games have more than one equilibrium point.

True False

d. The greedy algorithm always gives the best solution to the traveling salesman problem.

True False

5. (25 points) A person starting in Wichita must visit Kansas City, Omaha, and St. Louis (in any order), then return home to Wichita. You don't need to know that Omaha is north of Wichita, Kansas City is northeast, and St. Louis is east, but I'll tell you anyway. Approximate road mileages between the various cities are given below.

	Kansas City	Omaha	St. Louis	Wichita
Kansas City	—	220	225	280
Omaha	220	—	310	300
St. Louis	225	310	—	500
Wichita	280	300	500	—

a. Draw a weighted graph which corresponds to the situation.

b. Use the nearest neighbor algorithm to find an approximate solution to the traveling salesman problem, making a circuit starting at Wichita. What is the length of this circuit? (Write your answers in the spaces below.)

Wichita, _____, _____, _____, Wichita. Distance: _____

c. Use the greedy algorithm to find an approximate solution to the traveling salesman problem, making a circuit starting at Wichita. What is the length of this circuit? (Write your answers in the spaces below.)

Wichita, _____, _____, _____, Wichita. Distance: _____

d. Write the itinerary of the *shortest possible* solution to the traveling salesman problem in this case.

Wichita, _____, _____, _____, Wichita. Distance: _____

6. (20 points) The game of Crosscram has two players, H and V, who take turns placing their pieces on a checkerboard. H places 2×1 pieces horizontally, and V places 1×2 pieces vertically. In this game we will use a 4×2 board, shown at right. The first player who cannot place a tile loses.

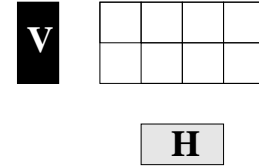

a. The compressed game tree if player H goes first is shown below. Using the game tree, indicate what strategy H should use in order to guarantee a win, no matter what V plays. (Circle the relevant parts of the game tree.)

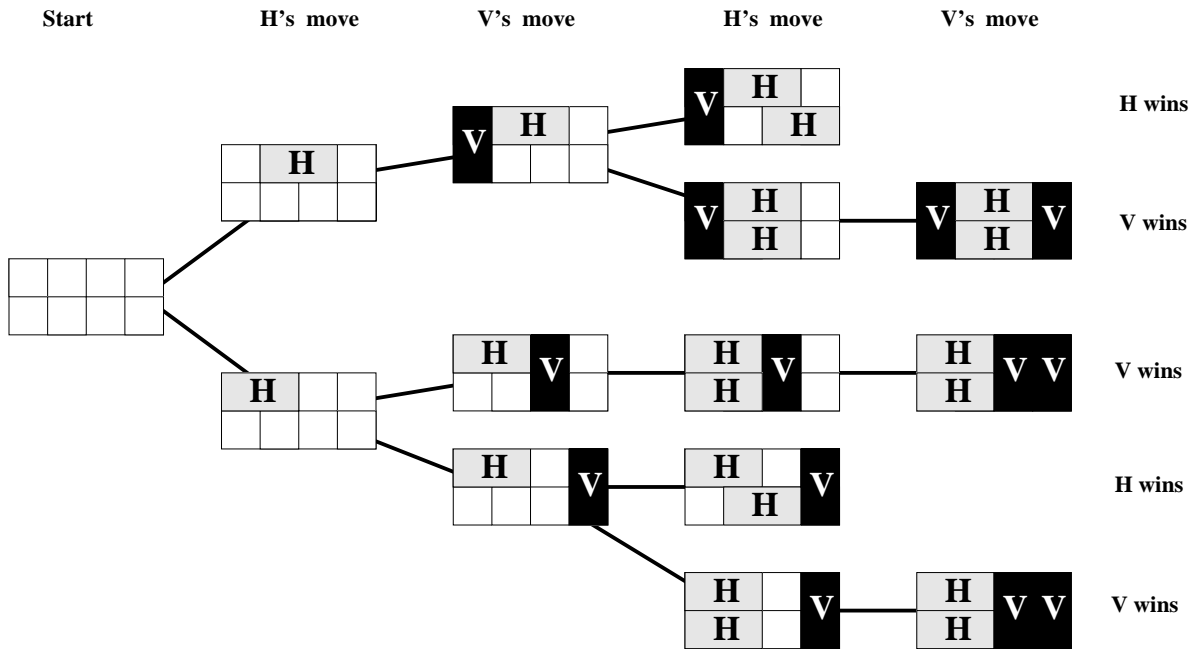

b. Even if V goes first, H can still win. Draw a partial game tree indicating what H's winning strategy is. Note that V has two essentially different starting moves. You must show H's response to every move V can make, but you only have to show those for H that result in a win for H; your goal is to describe H's winning strategy.

7. (25 points) In a presidential campaign, there are two candidates, a Democrat and a Republican, and two types of issues, domestic and foreign issues. Pollsters tell the Democrat that if both candidates campaign on domestic issues, he will gain 4 points in the polls. If both campaign on foreign issues, the Democrat will gain 3 points in the polls. If the Democrat concentrates on domestic issues while the Republican campaigns on foreign policy, the Democrat will lose 2 points in the polls. Finally, if the Democrat campaigns on foreign policy and the Republican concentrates on domestic policy, the Democrat will drop 1 point.

- a. This situation can be interpreted as a zero-sum game. Summarize this information in a payoff matrix, with the Democrat as the row player.

- b. What is the best strategy for each candidate? (Find the reduced payoff matrix.)

- c. If both candidates use the strategy you found above, how many points should the Democrat rise or fall in the polls?

8. (20 points) Two major oil producing countries are Kuwait and Qatar. Suppose that they must decide independently whether to charge high prices (H) or low prices (L). In this situation, their monthly gross revenue (in millions of dollars) will be indicated in the following payoff matrix:

	Qatar H	Qatar L
Kuwait H	(9, 9)	(5, 17)
Kuwait L	(17, 5)	(6, 6)

Assuming both Kuwait and Qatar act in order to maximize their own profit, and without communicating with each other, what action will each country take, and what is their anticipated revenue? Justify your answer.

This page is mostly blank so you can draw pictures or do calculations, as you like.