

# COURS DE LA CHAIRE D'EXCELLENCE



FONDATION  
SCIENCES  
MATHÉMATIQUES DE  
PARIS



INSTITUT DE MATHÉMATIQUES  
JUSSIEU - PARIS RIVE GAUCHE

## CLAUDE R. LEBRUN

STONY BROOK

ACCUEILLI À L'IMJ-PRG (SORBONNE UNIV., UNIV. PARIS CITÉ, CNRS)

# *EINSTEIN METRICS, FOUR-MANIFOLDS, AND DIFFERENTIAL TOPOLOGY*

AMPHITHÉÂTRE YVONNE CHOQUET-BRUHAT (BÂT. PERRIN)

JEUDI 19 MARS 2026

JEUDI 26 MARS 2026

JEUDI 2 AVRIL 2026

SALLE PIERRE GRISVARD (BÂT. BOREL, 3<sup>E</sup> ÉTAGE)

JEUDI 9 AVRIL 2026

JEUDI 16 AVRIL 2026

JEUDI 23 AVRIL 2026\*

DE 14H À 17H15

INSTITUT HENRI POINCARÉ

11, RUE PIERRE ET MARIE CURIE, 75005 PARIS

\* La durée totale du cours étant de 15h, une séance parmi les trois dernières indiquées sera supprimée, en concertation avec Claude LeBrun.

INFORMATIONS ET RÉSUMÉ DU COURS  
[WWW.SCIENCESMATHS-PARIS.FR](http://WWW.SCIENCESMATHS-PARIS.FR)



*Einstein Metrics,*

*Four-Manifolds, &*

*Differential Topology, V*

Claude LeBrun

Stony Brook University

Cours de la Chaire d'Excellence  
Fondation Sciences Mathématiques de Paris  
Institut Henri Poincaré, jeudi 16 avril 2026

**Definition.** Let  $M$  be a smooth compact oriented 4-manifold with  $b_+ \geq 2$ .

**Definition.** Let  $M$  be a smooth compact oriented 4-manifold with  $b_+ \geq 2$ . Then

$$a \in H^2(M, \mathbb{R})$$

**Definition.** Let  $M$  be a smooth compact oriented 4-manifold with  $b_+ \geq 2$ . Then

$$a \in H^2(M, \mathbb{R})$$

is called a *monopole class* of  $M$

**Definition.** Let  $M$  be a smooth compact oriented 4-manifold with  $b_+ \geq 2$ . Then

$$a \in H^2(M, \mathbb{R})$$

is called a monopole class of  $M$  iff there exists a  $\text{spin}^c$  structure on  $M$

**Definition.** Let  $M$  be a smooth compact oriented 4-manifold with  $b_+ \geq 2$ . Then

$$a \in H^2(M, \mathbb{R})$$

is called a monopole class of  $M$  iff there exists a  $\text{spin}^c$  structure on  $M$  with first Chern class

$$c_1^{\mathbb{R}}(L) = a$$

**Definition.** Let  $M$  be a smooth compact oriented 4-manifold with  $b_+ \geq 2$ . Then

$$a \in H^2(M, \mathbb{R})$$

is called a monopole class of  $M$  iff there exists a  $\text{spin}^c$  structure on  $M$  with first Chern class

$$c_1(L) = a \text{ mod torsion}$$

**Definition.** Let  $M$  be a smooth compact oriented 4-manifold with  $b_+ \geq 2$ . Then

$$a \in H^2(M, \mathbb{R})$$

is called a monopole class of  $M$  iff there exists a  $\text{spin}^c$  structure on  $M$  with first Chern class

$$c_1(L) = a \text{ mod torsion}$$

such that the Seiberg-Witten equations

**Definition.** Let  $M$  be a smooth compact oriented 4-manifold with  $b_+ \geq 2$ . Then

$$a \in H^2(M, \mathbb{R})$$

is called a monopole class of  $M$  iff there exists a  $\text{spin}^c$  structure on  $M$  with first Chern class

$$c_1(L) = a \text{ mod torsion}$$

such that the Seiberg-Witten equations

$$\begin{aligned} D_A \Phi &= 0 \\ F_A^+ &= i\sigma(\Phi). \end{aligned}$$

**Definition.** Let  $M$  be a smooth compact oriented 4-manifold with  $b_+ \geq 2$ . Then

$$a \in H^2(M, \mathbb{R})$$

is called a monopole class of  $M$  iff there exists a  $\text{spin}^c$  structure on  $M$  with first Chern class

$$c_1(L) = a \text{ mod torsion}$$

such that the Seiberg-Witten equations

$$\begin{aligned} D_A \Phi &= 0 \\ F_A^+ &= i\sigma(\Phi). \end{aligned}$$

have a solution  $(\Phi, A)$

**Definition.** Let  $M$  be a smooth compact oriented 4-manifold with  $b_+ \geq 2$ . Then

$$a \in H^2(M, \mathbb{R})$$

is called a monopole class of  $M$  iff there exists a  $\text{spin}^c$  structure on  $M$  with first Chern class

$$c_1(L) = a \text{ mod torsion}$$

such that the Seiberg-Witten equations

$$\begin{aligned} D_A \Phi &= 0 \\ F_A^+ &= i\sigma(\Phi). \end{aligned}$$

have a solution  $(\Phi, A)$  for every metric  $g$  on  $M$ .

**Proposition.** *Let  $M$  be a smooth compact oriented 4-manifold with  $b_+ \geq 2$ .*

**Proposition.** *Let  $M$  be a smooth compact oriented 4-manifold with  $b_+ \geq 2$ . The collection  $\mathcal{E} \subset H^2(M, \mathbb{R})$*

**Proposition.** *Let  $M$  be a smooth compact oriented 4-manifold with  $b_+ \geq 2$ . The collection  $\mathfrak{E} \subset H^2(M, \mathbb{R})$  of all monopole classes*

**Proposition.** *Let  $M$  be a smooth compact oriented 4-manifold with  $b_+ \geq 2$ . The collection  $\mathfrak{E} \subset H^2(M, \mathbb{R})$  of all monopole classes is finite,*

**Proposition.** *Let  $M$  be a smooth compact oriented 4-manifold with  $b_+ \geq 2$ . The collection  $\mathfrak{E} \subset H^2(M, \mathbb{R})$  of all monopole classes is finite, invariant under reflection through 0,*

**Proposition.** *Let  $M$  be a smooth compact oriented 4-manifold with  $b_+ \geq 2$ . The collection  $\mathfrak{E} \subset H^2(M, \mathbb{R})$  of all monopole classes is finite, invariant under reflection through 0, and is an oriented diffeomorphism invariant of  $M$ .*

**Proposition.** *Let  $M$  be a smooth compact oriented 4-manifold with  $b_+ \geq 2$ . The collection  $\mathfrak{E} \subset H^2(M, \mathbb{R})$  of all monopole classes is finite, invariant under reflection through 0, and is an oriented diffeomorphism invariant of  $M$ .*

---

**Proposition.** *Let  $M$  be a smooth compact oriented 4-manifold with  $b_+ \geq 2$ . The collection  $\mathfrak{E} \subset H^2(M, \mathbb{R})$  of all monopole classes is finite, invariant under reflection through 0, and is an oriented diffeomorphism invariant of  $M$ .*

---

Finiteness:

**Proposition.** *Let  $M$  be a smooth compact oriented 4-manifold with  $b_+ \geq 2$ . The collection  $\mathfrak{E} \subset H^2(M, \mathbb{R})$  of all monopole classes is finite, invariant under reflection through 0, and is an oriented diffeomorphism invariant of  $M$ .*

---

Finiteness: If  $\exists$  solution for  $(g, \mathfrak{c})$

**Proposition.** *Let  $M$  be a smooth compact oriented 4-manifold with  $b_+ \geq 2$ . The collection  $\mathfrak{E} \subset H^2(M, \mathbb{R})$  of all monopole classes is finite, invariant under reflection through 0, and is an oriented diffeomorphism invariant of  $M$ .*

---

Finiteness: If  $\exists$  solution for  $(g, \mathfrak{c})$

$$\int_M s_g^2 d\mu_g \geq 32\pi^2 [c_1(L)^+]^2$$

**Proposition.** *Let  $M$  be a smooth compact oriented 4-manifold with  $b_+ \geq 2$ . The collection  $\mathfrak{C} \subset H^2(M, \mathbb{R})$  of all monopole classes is finite, invariant under reflection through 0, and is an oriented diffeomorphism invariant of  $M$ .*

---

Finiteness: If  $\exists$  solution for  $(g, \mathfrak{c})$

$$\int_M s_g^2 d\mu_g \geq 32\pi^2 [c_1(L)^+]^2$$

So if  $v \in \mathcal{H}_g^+ \subset H^2(M, \mathbb{R})$  any unit vector, then

**Proposition.** *Let  $M$  be a smooth compact oriented 4-manifold with  $b_+ \geq 2$ . The collection  $\mathfrak{C} \subset H^2(M, \mathbb{R})$  of all monopole classes is finite, invariant under reflection through 0, and is an oriented diffeomorphism invariant of  $M$ .*

---

Finiteness: If  $\exists$  solution for  $(g, \mathfrak{c})$

$$\int_M s_g^2 d\mu_g \geq 32\pi^2 [c_1(L)^+]^2$$

So if  $v \in \mathcal{H}_g^+ \subset H^2(M, \mathbb{R})$  any unit vector, then

$$|v \bullet c_1(L)| \leq \frac{1}{4\pi\sqrt{2}} \|s_g\|_g$$

**Proposition.** *Let  $M$  be a smooth compact oriented 4-manifold with  $b_+ \geq 2$ . The collection  $\mathfrak{C} \subset H^2(M, \mathbb{R})$  of all monopole classes is finite, invariant under reflection through 0, and is an oriented diffeomorphism invariant of  $M$ .*

---

Finiteness: If  $\exists$  solution for  $(g, \mathfrak{c})$

$$\int_M s_g^2 d\mu_g \geq 32\pi^2 [c_1(L)^+]^2$$

So if  $v \in \mathcal{H}_g^+ \subset H^2(M, \mathbb{R})$  any unit vector, then

$$|v \bullet c_1(L)| \leq \frac{1}{4\pi\sqrt{2}} \|s_g\|_g \leq \|s_g\|_g$$

**Proposition.** *Let  $M$  be a smooth compact oriented 4-manifold with  $b_+ \geq 2$ . The collection  $\mathfrak{C} \subset H^2(M, \mathbb{R})$  of all monopole classes is finite, invariant under reflection through 0, and is an oriented diffeomorphism invariant of  $M$ .*

---

Finiteness: If  $\exists$  solution for  $(g, \mathfrak{c})$

$$\int_M s_g^2 d\mu_g \geq 32\pi^2 [c_1(L)^+]^2$$

So if  $v \in \mathcal{H}_g^+ \subset H^2(M, \mathbb{R})$  any unit vector, then

$$|v \bullet c_1(L)| \leq A_g := \|s_g\|_g$$

**Proposition.** *Let  $M$  be a smooth compact oriented 4-manifold with  $b_+ \geq 2$ . The collection  $\mathfrak{C} \subset H^2(M, \mathbb{R})$  of all monopole classes is finite, invariant under reflection through 0, and is an oriented diffeomorphism invariant of  $M$ .*

---

Finiteness: If  $\exists$  solution for  $(g, \mathfrak{c})$

$$\int_M s_g^2 d\mu_g \geq 32\pi^2 [c_1(L)^+]^2$$

So if  $v \in \mathcal{H}_g^+ \subset H^2(M, \mathbb{R})$  any unit vector, then

$$|v \bullet c_1(L)| \leq A_g := \|s_g\|_g$$

and hence

**Proposition.** *Let  $M$  be a smooth compact oriented 4-manifold with  $b_+ \geq 2$ . The collection  $\mathfrak{C} \subset H^2(M, \mathbb{R})$  of all monopole classes is finite, invariant under reflection through 0, and is an oriented diffeomorphism invariant of  $M$ .*

---

Finiteness: If  $\exists$  solution for  $(g, \mathfrak{c})$

$$\int_M s_g^2 d\mu_g \geq 32\pi^2 [c_1(L)^+]^2$$

So if  $v \in \mathcal{H}_g^+ \subset H^2(M, \mathbb{R})$  any unit vector, then

$$|v \bullet c_1(L)| \leq A_g := \|s_g\|_g$$

and hence

$$|v \bullet a| \leq A_g$$

**Proposition.** *Let  $M$  be a smooth compact oriented 4-manifold with  $b_+ \geq 2$ . The collection  $\mathfrak{C} \subset H^2(M, \mathbb{R})$  of all monopole classes is finite, invariant under reflection through 0, and is an oriented diffeomorphism invariant of  $M$ .*

---

Finiteness: If  $\exists$  solution for  $(g, \mathfrak{c})$

$$\int_M s_g^2 d\mu_g \geq 32\pi^2 [c_1(L)^+]^2$$

So if  $v \in \mathcal{H}_g^+ \subset H^2(M, \mathbb{R})$  any unit vector, then

$$|v \bullet c_1(L)| \leq A_g := \|s_g\|_g$$

and hence

$$|v \bullet a| \leq A_g$$

for every monopole class  $a$ .

**Proposition.** *Let  $M$  be a smooth compact oriented 4-manifold with  $b_+ \geq 2$ . The collection  $\mathfrak{C} \subset H^2(M, \mathbb{R})$  of all monopole classes is finite, invariant under reflection through 0, and is an oriented diffeomorphism invariant of  $M$ .*

---

Finiteness: If  $\exists$  solution for  $(g, \mathfrak{c})$

$$\int_M s_g^2 d\mu_g \geq 32\pi^2 [c_1(L)^+]^2$$

So if  $v \in \mathcal{H}_g^+ \subset H^2(M, \mathbb{R})$  any unit vector, then

$$|v \bullet c_1(L)| \leq A_g := \|s_g\|_g$$

and hence

$$|v \bullet a| \leq A_g$$

for every monopole class  $a$ .

Now use a result of Donaldson on period map.

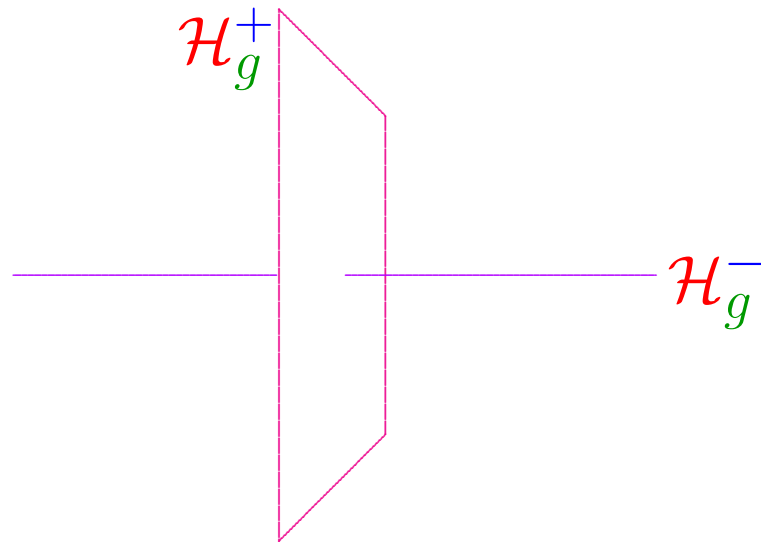

$$H^2(M, \mathbb{R})$$

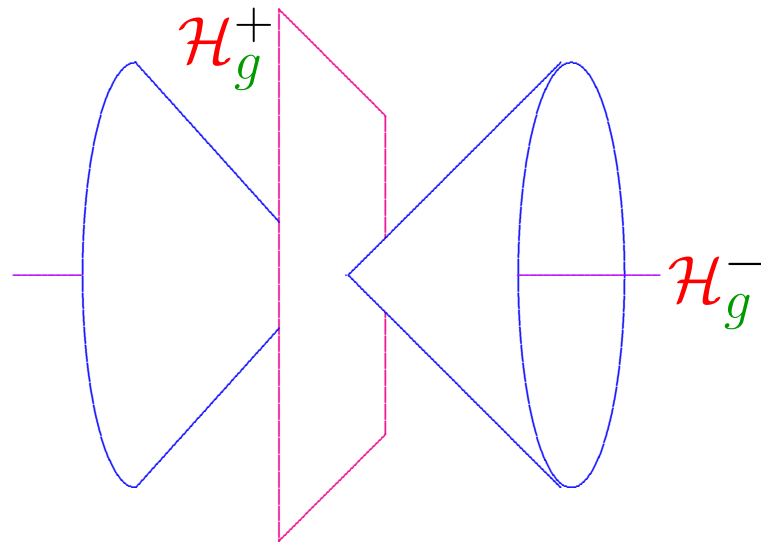

$$\{a \mid a \cdot a = 0\} \subset H^2(M, \mathbb{R})$$

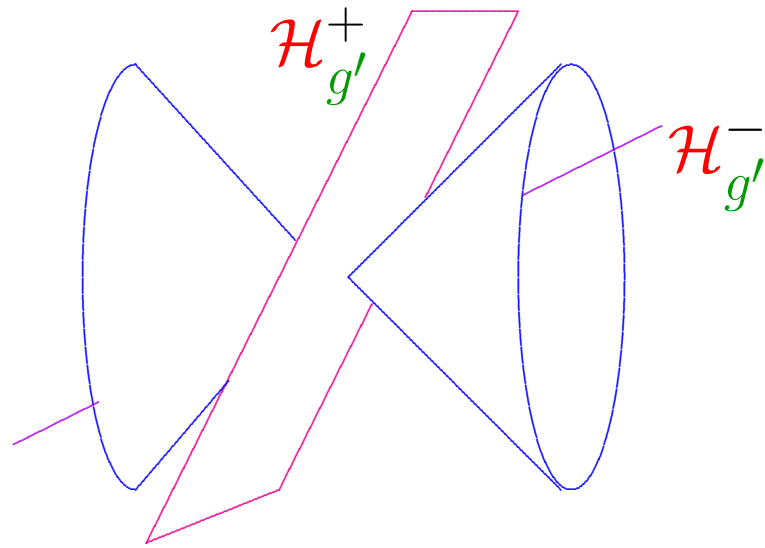

$$\{a \mid a \cdot a = 0\} \subset H^2(M, \mathbb{R})$$

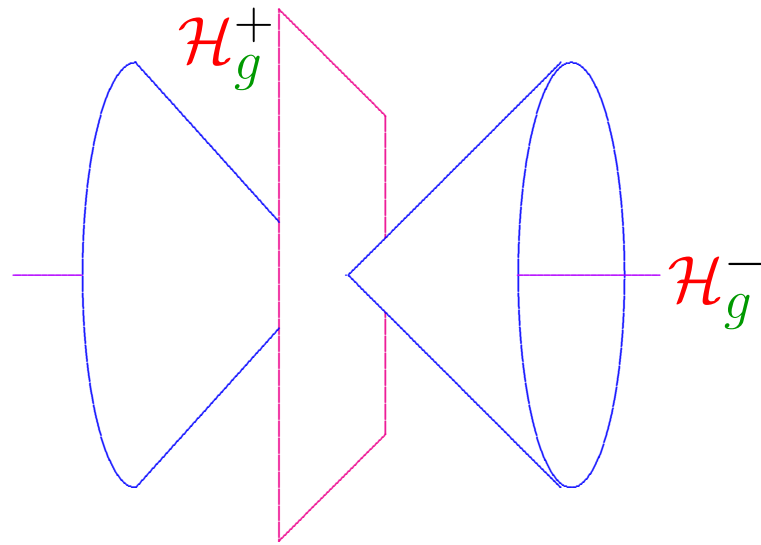

$$\{a \mid a \cdot a = 0\} \subset H^2(M, \mathbb{R})$$

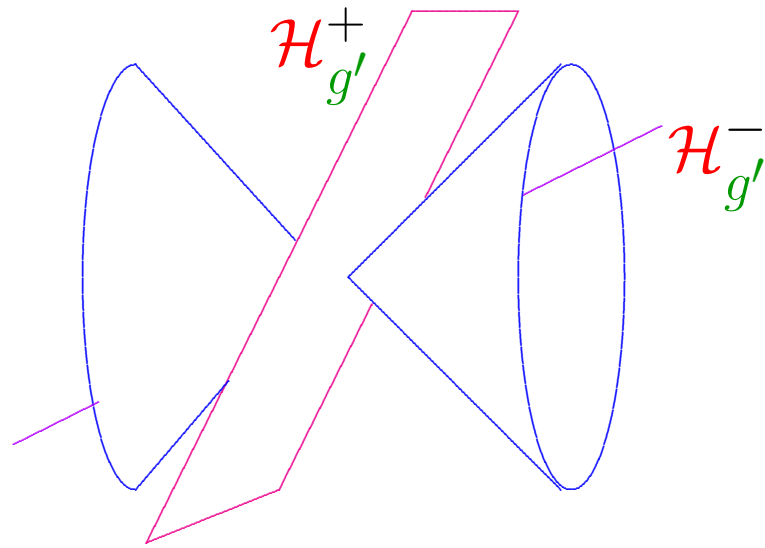

$$\{a \mid a \cdot a = 0\} \subset H^2(M, \mathbb{R})$$

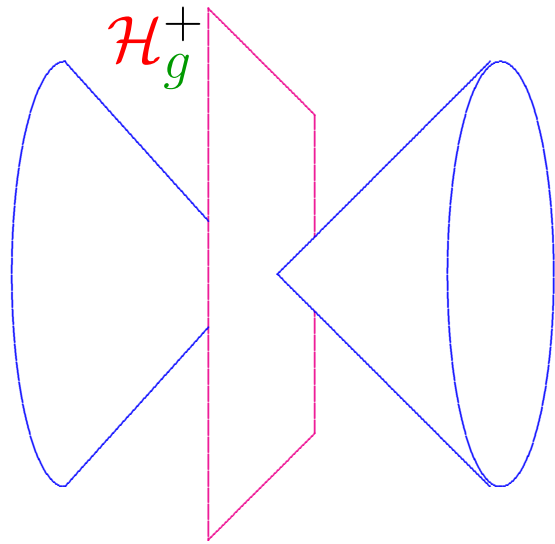

$$H^2(M, \mathbb{R})$$

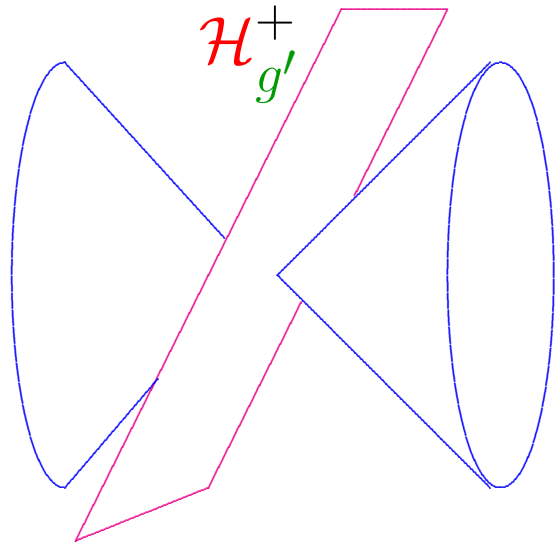

$$H^2(M, \mathbb{R})$$

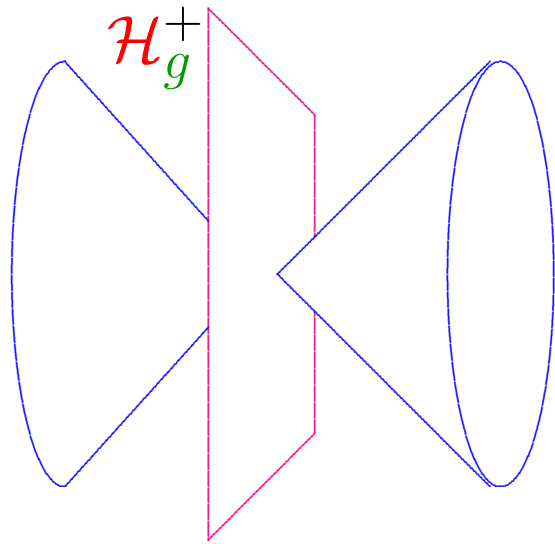

$$H^2(M, \mathbb{R})$$

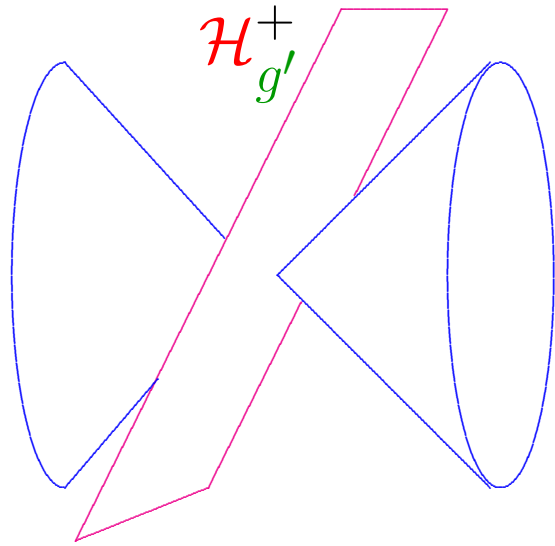

$$H^2(M, \mathbb{R})$$

Period map:

$$\{\text{Metrics on } M\} \longrightarrow Gr_{b_+}^+[H^2(M, \mathbb{R})]$$

Period map:

$$\begin{aligned} \{\text{Metrics on } M\} &\longrightarrow Gr_{b_+}^+[H^2(M, \mathbb{R})] \\ g &\longmapsto \mathcal{H}_g^+ \end{aligned}$$

Period map:

$$\begin{aligned} \{\text{Metrics on } M\} &\longrightarrow Gr_{b_+}^+[H^2(M, \mathbb{R})] \\ g &\longmapsto \mathcal{H}_g^+ \end{aligned}$$

Donaldson: period map is a submersion.

Period map:

$$\begin{aligned} \{\text{Metrics on } M\} &\longrightarrow Gr_{b_+}^+[H^2(M, \mathbb{R})] \\ g &\longmapsto \mathcal{H}_g^+ \end{aligned}$$

Donaldson: period map is a submersion.

$$\implies \bigcup_{g'} (\mathcal{H}_{g'}^+ - 0) \text{ open in } H^2(M, \mathbb{R}) - \{0\}.$$

Period map:

$$\begin{aligned} \{\text{Metrics on } M\} &\longrightarrow Gr_{b_+}^+[H^2(M, \mathbb{R})] \\ g &\longmapsto \mathcal{H}_g^+ \end{aligned}$$

Donaldson: period map is a submersion.

$$\implies \bigcup_{g'} (\mathcal{H}_{g'}^+ - 0) \text{ open in } H^2(M, \mathbb{R}) - \{0\}.$$

But any open set in a vector space spans the space!

Period map:

$$\begin{aligned} \{\text{Metrics on } M\} &\longrightarrow Gr_{b_+}^+[H^2(M, \mathbb{R})] \\ g &\longmapsto \mathcal{H}_g^+ \end{aligned}$$

Donaldson: period map is a submersion.

$$\implies \bigcup_{g'} (\mathcal{H}_{g'}^+ - 0) \text{ open in } H^2(M, \mathbb{R}) - \{0\}.$$

But any open set in a vector space spans the space!

$\therefore \exists (g_j, v_j), j = 1, \dots, b_2(M)$ , such that

Period map:

$$\begin{aligned} \{\text{Metrics on } M\} &\longrightarrow Gr_{b_+}^+[H^2(M, \mathbb{R})] \\ g &\longmapsto \mathcal{H}_g^+ \end{aligned}$$

Donaldson: period map is a submersion.

$$\implies \bigcup_{g'} (\mathcal{H}_{g'}^+ - 0) \text{ open in } H^2(M, \mathbb{R}) - \{0\}.$$

But any open set in a vector space spans the space!

$\therefore \exists (g_j, v_j), j = 1, \dots, b_2(M)$ , such that

$$v_j \in \mathcal{H}_{g_j}^+ - 0$$

Period map:

$$\begin{aligned} \{\text{Metrics on } M\} &\longrightarrow Gr_{b_+}^+[H^2(M, \mathbb{R})] \\ g &\longmapsto \mathcal{H}_g^+ \end{aligned}$$

Donaldson: period map is a submersion.

$$\implies \bigcup_{g'} (\mathcal{H}_{g'}^+ - 0) \text{ open in } H^2(M, \mathbb{R}) - \{0\}.$$

But any open set in a vector space spans the space!

$\therefore \exists (g_j, v_j), j = 1, \dots, b_2(M)$ , such that

$$v_j \in \mathcal{H}_{g_j}^+ - 0$$

and such that  $\{v_j\}_{j=1}^{b_2}$  forms a basis for  $H^2(M, \mathbb{R})$ .

Period map:

$$\begin{aligned} \{\text{Metrics on } M\} &\longrightarrow Gr_{b_+}^+[H^2(M, \mathbb{R})] \\ g &\longmapsto \mathcal{H}_g^+ \end{aligned}$$

Donaldson: period map is a submersion.

$$\implies \bigcup_{g'} (\mathcal{H}_{g'}^+ - 0) \text{ open in } H^2(M, \mathbb{R}) - \{0\}.$$

But any open set in a vector space spans the space!

$\therefore \exists (g_j, v_j), j = 1, \dots, b_2(M)$ , such that

$$v_j \in \mathcal{H}_{g_j}^+ - 0$$

and such that  $\{v_j\}_{j=1}^{b_2}$  forms a basis for  $H^2(M, \mathbb{R})$ .

We may also normalize so that  $v_j^2 = 1$  for each  $j$ .

**Proposition.** *Let  $M$  be a smooth compact oriented 4-manifold with  $b_+ \geq 2$ . The collection  $\mathfrak{E} \subset H^2(M, \mathbb{R})$  of all monopole classes is finite, invariant under reflection through 0, and is an oriented diffeomorphism invariant of  $M$ .*

---

Finiteness: If  $a$  any monopole class, then

$$|v \bullet a| \leq A_g = \|s_g\|_g$$

for any unit  $v \in \mathcal{H}_g^+$ .

**Proposition.** *Let  $M$  be a smooth compact oriented 4-manifold with  $b_+ \geq 2$ . The collection  $\mathfrak{E} \subset H^2(M, \mathbb{R})$  of all monopole classes is finite, invariant under reflection through 0, and is an oriented diffeomorphism invariant of  $M$ .*

---

Finiteness: If  $a$  any monopole class, then

$$\begin{aligned}
 |v_1 \bullet a| &\leq A_{g_1} = \|s_{g_1}\|_{g_1} \\
 |v_2 \bullet a| &\leq A_{g_2} = \|s_{g_2}\|_{g_2} \\
 &\vdots \\
 |v_{b_2} \bullet a| &\leq A_{g_{b_2}} = \|s_{g_{b_2}}\|_{g_{b_2}}
 \end{aligned}$$

for our chosen unit  $v_j \in \mathcal{H}_{g_j}^+$ .

**Proposition.** *Let  $M$  be a smooth compact oriented 4-manifold with  $b_+ \geq 2$ . The collection  $\mathfrak{E} \subset H^2(M, \mathbb{R})$  of all monopole classes is finite, invariant under reflection through 0, and is an oriented diffeomorphism invariant of  $M$ .*

---

Finiteness: If  $a$  any monopole class, then

$$\begin{aligned} |v_1 \bullet a| &\leq A_{g_1} \\ |v_2 \bullet a| &\leq A_{g_2} \\ &\vdots \\ |v_{b_2} \bullet a| &\leq A_{g_{b_2}} \end{aligned}$$

for our chosen linearly independent  $v_j$ .

**Proposition.** *Let  $M$  be a smooth compact oriented 4-manifold with  $b_+ \geq 2$ . The collection  $\mathfrak{E} \subset H^2(M, \mathbb{R})$  of all monopole classes is finite, invariant under reflection through 0, and is an oriented diffeomorphism invariant of  $M$ .*

---

Finiteness: If  $a$  any monopole class, then

$$\begin{aligned} |v_1 \bullet a| &\leq A_{g_1} \\ |v_2 \bullet a| &\leq A_{g_2} \\ &\vdots \\ |v_{b_2} \bullet a| &\leq A_{g_{b_2}} \end{aligned}$$

for our chosen linearly independent  $v_j$ .  
So  $\mathfrak{E} \subset$  compact parallelepiped

**Proposition.** *Let  $M$  be a smooth compact oriented 4-manifold with  $b_+ \geq 2$ . The collection  $\mathfrak{E} \subset H^2(M, \mathbb{R})$  of all monopole classes is finite, invariant under reflection through 0, and is an oriented diffeomorphism invariant of  $M$ .*

---

Finiteness: If  $a$  any monopole class, then

$$\begin{aligned} |v_1 \bullet a| &\leq A_{g_1} \\ |v_2 \bullet a| &\leq A_{g_2} \\ &\vdots \\ |v_{b_2} \bullet a| &\leq A_{g_{b_2}} \end{aligned}$$

for our chosen linearly independent  $v_j$ .

So  $\mathfrak{E} \subset$  compact parallelepiped  $\cap$  integer lattice!

**Proposition.** *Let  $M$  be a smooth compact oriented 4-manifold with  $b_+ \geq 2$ . The collection  $\mathfrak{E} \subset H^2(M, \mathbb{R})$  of all monopole classes is finite, invariant under reflection through 0, and is an oriented diffeomorphism invariant of  $M$ .*

---

Finiteness: If  $a$  any monopole class, then

$$\begin{aligned} |v_1 \bullet a| &\leq A_{g_1} \\ |v_2 \bullet a| &\leq A_{g_2} \\ &\vdots \\ |v_{b_2} \bullet a| &\leq A_{g_{b_2}} \end{aligned}$$

for our chosen linearly independent  $v_j$ .

So  $\mathfrak{E} \subset$  compact parallelepiped  $\cap$  integer lattice!

$\implies$  Finite!

**Proposition.** *Let  $M$  be a smooth compact oriented 4-manifold with  $b_+ \geq 2$ . The collection  $\mathfrak{E} \subset H^2(M, \mathbb{R})$  of all monopole classes is finite, invariant under reflection through 0, and is an oriented diffeomorphism invariant of  $M$ .*

---

**Proposition.** *Let  $M$  be a smooth compact oriented 4-manifold with  $b_+ \geq 2$ . The collection  $\mathfrak{E} \subset H^2(M, \mathbb{R})$  of all monopole classes is finite, invariant under reflection through 0, and is an oriented diffeomorphism invariant of  $M$ .*

---

Reflection invariance:

**Proposition.** *Let  $M$  be a smooth compact oriented 4-manifold with  $b_+ \geq 2$ . The collection  $\mathfrak{E} \subset H^2(M, \mathbb{R})$  of all monopole classes is finite, invariant under reflection through 0, and is an oriented diffeomorphism invariant of  $M$ .*

---

Reflection invariance: Complex conjugation

**Proposition.** *Let  $M$  be a smooth compact oriented 4-manifold with  $b_+ \geq 2$ . The collection  $\mathfrak{E} \subset H^2(M, \mathbb{R})$  of all monopole classes is finite, invariant under reflection through 0, and is an oriented diffeomorphism invariant of  $M$ .*

---

Reflection invariance: Complex conjugation

$$\mathbb{V}_+ \rightarrow \overline{\mathbb{V}_+}$$

**Proposition.** *Let  $M$  be a smooth compact oriented 4-manifold with  $b_+ \geq 2$ . The collection  $\mathfrak{E} \subset H^2(M, \mathbb{R})$  of all monopole classes is finite, invariant under reflection through 0, and is an oriented diffeomorphism invariant of  $M$ .*

---

Reflection invariance: Complex conjugation

$$\mathbb{V}_+ \rightarrow \overline{\mathbb{V}_+}$$

acts on SW solutions by

**Proposition.** *Let  $M$  be a smooth compact oriented 4-manifold with  $b_+ \geq 2$ . The collection  $\mathfrak{E} \subset H^2(M, \mathbb{R})$  of all monopole classes is finite, invariant under reflection through 0, and is an oriented diffeomorphism invariant of  $M$ .*

---

Reflection invariance: Complex conjugation

$$\mathbb{V}_+ \rightarrow \overline{\mathbb{V}_+}$$

acts on SW solutions by

$$(\Phi, A) \mapsto (\overline{\Phi}, A^*).$$

**Proposition.** *Let  $M$  be a smooth compact oriented 4-manifold with  $b_+ \geq 2$ . The collection  $\mathfrak{E} \subset H^2(M, \mathbb{R})$  of all monopole classes is finite, invariant under reflection through 0, and is an oriented diffeomorphism invariant of  $M$ .*

---

Reflection invariance: Complex conjugation

$$\mathbb{V}_+ \rightarrow \overline{\mathbb{V}_+}$$

acts on SW solutions by

$$(\Phi, A) \mapsto (\overline{\Phi}, A^*).$$

Since  $L = \det(\mathbb{V}_+)$ , also sends

**Proposition.** *Let  $M$  be a smooth compact oriented 4-manifold with  $b_+ \geq 2$ . The collection  $\mathfrak{E} \subset H^2(M, \mathbb{R})$  of all monopole classes is finite, invariant under reflection through 0, and is an oriented diffeomorphism invariant of  $M$ .*

---

Reflection invariance: Complex conjugation

$$\mathbb{V}_+ \rightarrow \overline{\mathbb{V}_+}$$

acts on SW solutions by

$$(\Phi, A) \mapsto (\overline{\Phi}, A^*).$$

Since  $L = \det(\mathbb{V}_+)$ , also sends

$$c_1(L) \rightsquigarrow c_1(L^*) = -c_1(L)$$

**Proposition.** *Let  $M$  be a smooth compact oriented 4-manifold with  $b_+ \geq 2$ . The collection  $\mathfrak{E} \subset H^2(M, \mathbb{R})$  of all monopole classes is finite, invariant under reflection through 0, and is an oriented diffeomorphism invariant of  $M$ .*

---

Reflection invariance: Complex conjugation

$$\mathbb{V}_+ \rightarrow \overline{\mathbb{V}_+}$$

acts on SW solutions by

$$(\Phi, A) \mapsto (\overline{\Phi}, A^*).$$

Since  $L = \det(\mathbb{V}_+)$ , also sends

$$c_1(L) \rightsquigarrow c_1(L^*) = -c_1(L)$$

So whenever  $a = c_1^{\mathbb{R}}(L)$  is a monopole class,

**Proposition.** *Let  $M$  be a smooth compact oriented 4-manifold with  $b_+ \geq 2$ . The collection  $\mathfrak{E} \subset H^2(M, \mathbb{R})$  of all monopole classes is finite, invariant under reflection through 0, and is an oriented diffeomorphism invariant of  $M$ .*

---

Reflection invariance: Complex conjugation

$$\mathbb{V}_+ \rightarrow \overline{\mathbb{V}_+}$$

acts on SW solutions by

$$(\Phi, A) \mapsto (\overline{\Phi}, A^*).$$

Since  $L = \det(\mathbb{V}_+)$ , also sends

$$c_1(L) \rightsquigarrow c_1(L^*) = -c_1(L)$$

So whenever  $a = c_1^{\mathbb{R}}(L)$  is a monopole class,  $-a = c_1^{\mathbb{R}}(L^*)$  is also a monopole class.

Allows us to define the following simple invariant:

Allows us to define the following simple invariant:

**Definition.** *Let  $M$  be a smooth compact oriented 4-manifold with  $b_+(M) \geq 2$ .*

Allows us to define the following simple invariant:

**Definition.** *Let  $M$  be a smooth compact oriented 4-manifold with  $b_+(M) \geq 2$ . Let*

$$\mathfrak{e} \subset H^2(M, \mathbb{Z})/\text{torsion}$$

Allows us to define the following simple invariant:

**Definition.** *Let  $M$  be a smooth compact oriented 4-manifold with  $b_+(M) \geq 2$ . Let*

$$\mathfrak{e} \subset H^2(M, \mathbb{Z})/\text{torsion}$$

*be the set of monopole classes of  $M$ .*

Allows us to define the following simple invariant:

**Definition.** *Let  $M$  be a smooth compact oriented 4-manifold with  $b_+(M) \geq 2$ . Let*

$$\mathfrak{E} \subset H^2(M, \mathbb{Z})/\text{torsion}$$

*be the set of monopole classes of  $M$ . If*

$$\mathfrak{E} \not\subset \{0\}$$

Allows us to define the following simple invariant:

**Definition.** Let  $M$  be a smooth compact oriented 4-manifold with  $b_+(M) \geq 2$ . Let

$$\mathfrak{E} \subset H^2(M, \mathbb{Z})/\text{torsion}$$

be the set of monopole classes of  $M$ . If

$$\mathfrak{E} \not\subset \{0\}$$

we define the **bandwidth** of  $M$  to be

Allows us to define the following simple invariant:

**Definition.** Let  $M$  be a smooth compact oriented 4-manifold with  $b_+(M) \geq 2$ . Let

$$\mathfrak{E} \subset H^2(M, \mathbb{Z})/\text{torsion}$$

be the set of monopole classes of  $M$ . If

$$\mathfrak{E} \not\subset \{0\}$$

we define the **bandwidth** of  $M$  to be

$$\mathcal{BW}(M) = \max \{n \in \mathbb{Z}^+ \mid \exists a \neq b \in \mathfrak{E}, \text{ s.t. } 2n \mid (a - b)\}.$$

Allows us to define the following simple invariant:

**Definition.** Let  $M$  be a smooth compact oriented 4-manifold with  $b_+(M) \geq 2$ . Let

$$\mathfrak{E} \subset H^2(M, \mathbb{Z})/\text{torsion}$$

be the set of monopole classes of  $M$ . If

$$\mathfrak{E} \not\subset \{0\}$$

we define the **bandwidth** of  $M$  to be

$$\mathcal{BW}(M) = \max \{n \in \mathbb{Z}^+ \mid \exists a \neq b \in \mathfrak{E}, \text{ s.t. } 2n \mid (a - b)\}.$$

If, on the other hand,  $\mathfrak{E} \subset \{0\}$ , we define the bandwidth  $\mathcal{BW}(M)$  to be 0.

Allows us to define the following simple invariant:

**Definition.** Let  $M$  be a smooth compact oriented 4-manifold with  $b_+(M) \geq 2$ . Let

$$\mathfrak{E} \subset H^2(M, \mathbb{Z})/\text{torsion}$$

be the set of monopole classes of  $M$ . If

$$\mathfrak{E} \not\subset \{0\}$$

we define the **bandwidth** of  $M$  to be

$$\mathcal{BW}(M) = \max \{n \in \mathbb{Z}^+ \mid \exists a \neq b \in \mathfrak{E}, \text{ s.t. } 2n \mid (a - b)\}.$$

If, on the other hand,  $\mathfrak{E} \subset \{0\}$ , we define the bandwidth  $\mathcal{BW}(M)$  to be 0.

Notice that this of course assigns a specific natural number to each differentiable structure.

**Example.** Let  $M$  be 4-manifold with  $b_+ > 1$ .

**Example.** When  $\mathfrak{c}$  arises from an almost-complex structure  $J$  on  $M$ ,

**Example.** When  $\mathfrak{c}$  arises from an almost-complex structure  $J$  on  $M$ , and satisfies  $n_{\mathfrak{c}}(M) \neq 0 \in \mathbb{Z}_2$ ,

**Example.** When  $\mathbf{c}$  arises from an almost-complex structure  $J$  on  $M$ , and satisfies  $n_{\mathbf{c}}(M) \neq 0 \in \mathbb{Z}_2$ , then  $c_1^{\mathbb{R}}(M, J)$  is a basic class.

**Example.** When  $\mathfrak{c}$  arises from an almost-complex structure  $J$  on  $M$ , and satisfies  $n_{\mathfrak{c}}(M) \neq 0 \in \mathbb{Z}_2$ , then  $c_1^{\mathbb{R}}(M, J)$  is a monopole class.

**Example.** When  $\mathbf{c}$  arises from an almost-complex structure  $J$  on  $M$ , and satisfies  $n_{\mathbf{c}}(M) \neq 0 \in \mathbb{Z}_2$ , then  $c_1^{\mathbb{R}}(M, J)$  is a monopole class.

When  $J$  is integrable and  $b_1$  even, we saw last time that  $c_1(M, J)$  is therefore a monopole class.

**Example.** When  $\mathbf{c}$  arises from an almost-complex structure  $J$  on  $M$ , and satisfies  $n_{\mathbf{c}}(M) \neq 0 \in \mathbb{Z}_2$ , then  $c_1^{\mathbb{R}}(M, J)$  is a monopole class.

When  $J$  is integrable and  $b_1$  even, we saw last time that  $c_1(M, J)$  is therefore a monopole class.

“basic class”

**Example.** When  $\mathfrak{c}$  arises from an almost-complex structure  $J$  on  $M$ , and satisfies  $n_{\mathfrak{c}}(M) \neq 0 \in \mathbb{Z}_2$ , then  $c_1^{\mathbb{R}}(M, J)$  is a monopole class.

When  $J$  is integrable and  $b_1$  even, we saw last time that  $c_1(M, J)$  is therefore a monopole class.

**Example.** When  $\mathbf{c}$  arises from an almost-complex structure  $J$  on  $M$ , and satisfies  $n_{\mathbf{c}}(M) \neq 0 \in \mathbb{Z}_2$ , then  $c_1^{\mathbb{R}}(M, J)$  is a monopole class.

When  $J$  is integrable and  $b_1$  even, we saw last time that  $c_1(M, J)$  is therefore a monopole class.

On  $K3$ , only monopole class is  $0 \in H^2(M, \mathbb{Z})$ .

**Example.** When  $\mathbf{c}$  arises from an almost-complex structure  $J$  on  $M$ , and satisfies  $n_{\mathbf{c}}(M) \neq 0 \in \mathbb{Z}_2$ , then  $c_1^{\mathbb{R}}(M, J)$  is a monopole class.

When  $J$  is integrable and  $b_1$  even, we saw last time that  $c_1(M, J)$  is therefore a monopole class.

On  $K3$ , only monopole class is  $0 \in H^2(M, \mathbb{Z})$ .

Different for any Kodaira “homotopy  $K3$ .”

**Example.** When  $\mathbf{c}$  arises from an almost-complex structure  $J$  on  $M$ , and satisfies  $n_{\mathbf{c}}(M) \neq 0 \in \mathbb{Z}_2$ , then  $c_1^{\mathbb{R}}(M, J)$  is a monopole class.

When  $J$  is integrable and  $b_1$  even, we saw last time that  $c_1(M, J)$  is therefore a monopole class.

On  $K3$ , only monopole class is  $0 \in H^2(M, \mathbb{Z})$ .

Different for any Kodaira “homotopy  $K3$ .”

$K3 =$  resolution of  $T^4/\mathbb{Z}_2$ :

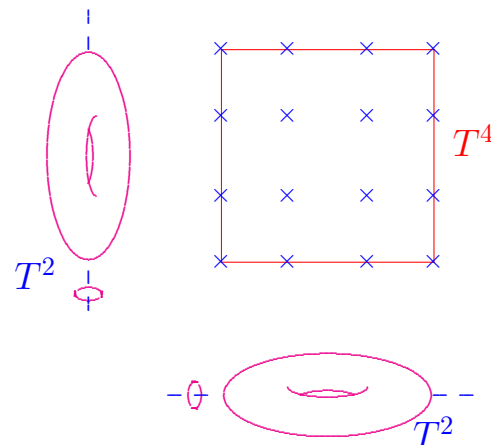

**Example.** When  $\mathbf{c}$  arises from an almost-complex structure  $J$  on  $M$ , and satisfies  $n_{\mathbf{c}}(M) \neq 0 \in \mathbb{Z}_2$ , then  $c_1^{\mathbb{R}}(M, J)$  is a monopole class.

When  $J$  is integrable and  $b_1$  even, we saw last time that  $c_1(M, J)$  is therefore a monopole class.

On  $K3$ , only monopole class is  $0 \in H^2(M, \mathbb{Z})$ .

Different for any Kodaira “homotopy  $K3$ .”

$K3 =$  resolution of  $T^4/\mathbb{Z}_2$ :

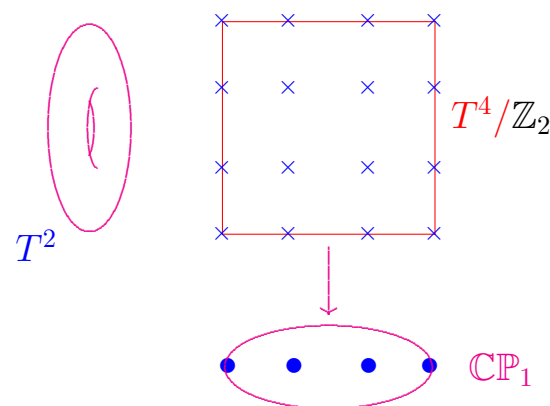

**Example.** When  $\mathbf{c}$  arises from an almost-complex structure  $J$  on  $M$ , and satisfies  $n_{\mathbf{c}}(M) \neq 0 \in \mathbb{Z}_2$ , then  $c_1^{\mathbb{R}}(M, J)$  is a monopole class.

When  $J$  is integrable and  $b_1$  even, we saw last time that  $c_1(M, J)$  is therefore a monopole class.

On  $K3$ , only monopole class is  $0 \in H^2(M, \mathbb{Z})$ .

Different for any Kodaira “homotopy  $K3$ .”

$K3 =$  resolution of  $T^4/\mathbb{Z}_2$ :

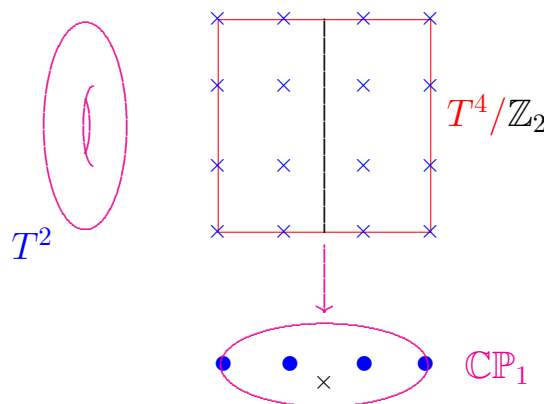

**Example.** When  $\mathbf{c}$  arises from an almost-complex structure  $J$  on  $M$ , and satisfies  $n_{\mathbf{c}}(M) \neq 0 \in \mathbb{Z}_2$ , then  $c_1^{\mathbb{R}}(M, J)$  is a monopole class.

When  $J$  is integrable and  $b_1$  even, we saw last time that  $c_1(M, J)$  is therefore a monopole class.

On  $K3$ , only monopole class is  $0 \in H^2(M, \mathbb{Z})$ .

Different for any Kodaira “homotopy  $K3$ .”

Replace chosen fiber  $T^2$  with  $T^2/\mathbb{Z}_{2\ell+1}$

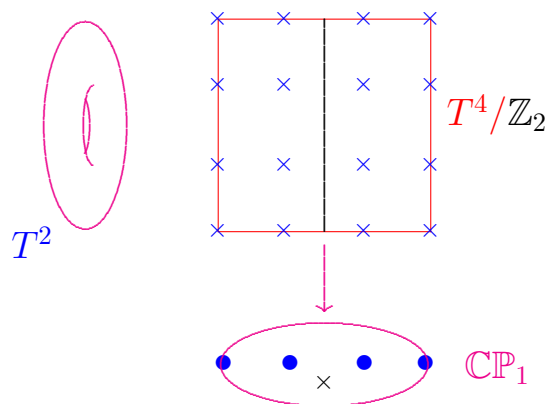

**Example.** When  $\mathbf{c}$  arises from an almost-complex structure  $J$  on  $M$ , and satisfies  $n_{\mathbf{c}}(M) \neq 0 \in \mathbb{Z}_2$ , then  $c_1^{\mathbb{R}}(M, J)$  is a monopole class.

When  $J$  is integrable and  $b_1$  even, we saw last time that  $c_1(M, J)$  is therefore a monopole class.

On  $K3$ , only monopole class is  $0 \in H^2(M, \mathbb{Z})$ .

Different for any Kodaira “homotopy  $K3$ .”

**Key:**  $[T^2 \times (D^2 - \{0\})] / \mathbb{Z}_{2\ell+1} \cong T^2 \times (D^2 - \{0\})$ .

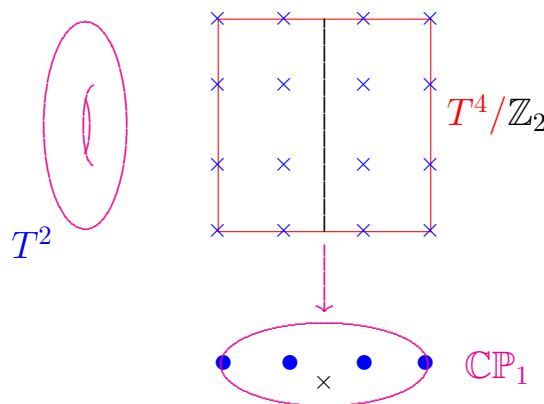

**Example.** When  $\mathbf{c}$  arises from an almost-complex structure  $J$  on  $M$ , and satisfies  $n_{\mathbf{c}}(M) \neq 0 \in \mathbb{Z}_2$ , then  $c_1^{\mathbb{R}}(M, J)$  is a monopole class.

When  $J$  is integrable and  $b_1$  even, we saw last time that  $c_1(M, J)$  is therefore a monopole class.

On  $K3$ , only monopole class is  $0 \in H^2(M, \mathbb{Z})$ .

Different for any Kodaira “homotopy  $K3$ .”

Homotopy equivalent to  $K3$ ,

**Example.** When  $\mathbf{c}$  arises from an almost-complex structure  $J$  on  $M$ , and satisfies  $n_{\mathbf{c}}(M) \neq 0 \in \mathbb{Z}_2$ , then  $c_1^{\mathbb{R}}(M, J)$  is a monopole class.

When  $J$  is integrable and  $b_1$  even, we saw last time that  $c_1(M, J)$  is therefore a monopole class.

On  $K3$ , only monopole class is  $0 \in H^2(M, \mathbb{Z})$ .

Different for any Kodaira “homotopy  $K3$ .”

Homotopy equivalent to  $K3$ , but  $c_1 = -2\ell f$ ,

**Example.** When  $\mathbf{c}$  arises from an almost-complex structure  $J$  on  $M$ , and satisfies  $n_{\mathbf{c}}(M) \neq 0 \in \mathbb{Z}_2$ , then  $c_1^{\mathbb{R}}(M, J)$  is a monopole class.

When  $J$  is integrable and  $b_1$  even, we saw last time that  $c_1(M, J)$  is therefore a monopole class.

On  $K3$ , only monopole class is  $0 \in H^2(M, \mathbb{Z})$ .

Different for any Kodaira “homotopy  $K3$ .”

Homotopy equivalent to  $K3$ , but  $c_1 = -2\ell\mathbf{f}$ ,

where  $\mathbf{f} \neq 0$  is homology class of new  $T^2/\mathbb{Z}_{2\ell+1}$ .

**Example.** When  $\mathbf{c}$  arises from an almost-complex structure  $J$  on  $M$ , and satisfies  $n_{\mathbf{c}}(M) \neq 0 \in \mathbb{Z}_2$ , then  $c_1^{\mathbb{R}}(M, J)$  is a monopole class.

When  $J$  is integrable and  $b_1$  even, we saw last time that  $c_1(M, J)$  is therefore a monopole class.

On  $K3$ , only monopole class is  $0 \in H^2(M, \mathbb{Z})$ .

Different for any Kodaira “homotopy  $K3$ .”

Homotopy equivalent to  $K3$ , but  $c_1 = -2\ell\mathbf{f}$ ,

where  $\mathbf{f} \neq 0$  is homology class of new  $T^2/\mathbb{Z}_{2\ell+1}$ .

Produces non-zero monopole class divisible by  $2\ell$ .

**Example.** When  $\mathbf{c}$  arises from an almost-complex structure  $J$  on  $M$ , and satisfies  $n_{\mathbf{c}}(M) \neq 0 \in \mathbb{Z}_2$ , then  $c_1^{\mathbb{R}}(M, J)$  is a monopole class.

When  $J$  is integrable and  $b_1$  even, we saw last time that  $c_1(M, J)$  is therefore a monopole class.

On  $K3$ , only monopole class is  $0 \in H^2(M, \mathbb{Z})$ .

Different for any Kodaira “homotopy  $K3$ .”

Homotopy equivalent to  $K3$ , but  $c_1 = -2\ell\mathbf{f}$ ,  
where  $\mathbf{f} \neq 0$  is homology class of new  $T^2/\mathbb{Z}_{2\ell+1}$ .

Produces non-zero monopole class divisible by  $2\ell$ :

$$BW(M_{\ell}) \geq 2\ell.$$

**Example.** When  $\mathbf{c}$  arises from an almost-complex structure  $J$  on  $M$ , and satisfies  $n_{\mathbf{c}}(M) \neq 0 \in \mathbb{Z}_2$ , then  $c_1^{\mathbb{R}}(M, J)$  is a monopole class.

When  $J$  is integrable and  $b_1$  even, we saw last time that  $c_1(M, J)$  is therefore a monopole class.

On  $K3$ , only monopole class is  $0 \in H^2(M, \mathbb{Z})$ .

Different for any Kodaira “homotopy  $K3$ .”

Homeomorphic to  $K3$ , but  $c_1 = -2\ell\mathbf{f}$ ,

where  $\mathbf{f} \neq 0$  is homology class of new  $T^2/\mathbb{Z}_{2\ell+1}$ .

Produces non-zero monopole class divisible by  $2\ell$ :

$$BW(M_{\ell}) \geq 2\ell.$$

**Example.** When  $\mathbf{c}$  arises from an almost-complex structure  $J$  on  $M$ , and satisfies  $n_{\mathbf{c}}(M) \neq 0 \in \mathbb{Z}_2$ , then  $c_1^{\mathbb{R}}(M, J)$  is a monopole class.

When  $J$  is integrable and  $b_1$  even, we saw last time that  $c_1(M, J)$  is therefore a monopole class.

On  $K3$ , only monopole class is  $0 \in H^2(M, \mathbb{Z})$ .

Different for any Kodaira “homotopy  $K3$ .”

Homeomorphic to  $K3$ , but  $c_1 = -2\ell\mathbf{f}$ ,

where  $\mathbf{f} \neq 0$  is homology class of new  $T^2/\mathbb{Z}_{2\ell+1}$ .

Produces non-zero monopole class divisible by  $2\ell$ .

As  $\ell \rightarrow \infty$ ,  $BW(M_\ell) \rightarrow \infty$ .

**Example.** When  $\mathbf{c}$  arises from an almost-complex structure  $J$  on  $M$ , and satisfies  $n_{\mathbf{c}}(M) \neq 0 \in \mathbb{Z}_2$ , then  $c_1^{\mathbb{R}}(M, J)$  is a monopole class.

When  $J$  is integrable and  $b_1$  even, we saw last time that  $c_1(M, J)$  is therefore a monopole class.

On  $K3$ , only monopole class is  $0 \in H^2(M, \mathbb{Z})$ .

Different for any Kodaira “homotopy  $K3$ .”

Homeomorphic to  $K3$ , but  $c_1 = -2\ell\mathbf{f}$ ,

where  $\mathbf{f} \neq 0$  is homology class of new  $T^2/\mathbb{Z}_{2\ell+1}$ .

Produces non-zero monopole class divisible by  $2\ell$ .

As  $\ell \rightarrow \infty$ , get infinitely many different diffeomorphism types: if finite,  $\mathcal{BW}$  would be bounded!

**Example.** When  $\mathbf{c}$  arises from an almost-complex structure  $J$  on  $M$ , and satisfies  $n_{\mathbf{c}}(M) \neq 0 \in \mathbb{Z}_2$ , then  $c_1^{\mathbb{R}}(M, J)$  is a monopole class.

When  $J$  is integrable and  $b_1$  even, we saw last time that  $c_1(M, J)$  is therefore a monopole class.

On  $K3$ , only monopole class is  $0 \in H^2(M, \mathbb{Z})$ .

Different for any Kodaira “homotopy  $K3$ .”

**Proposition.** *The topological manifold  $|K3|$  admits infinitely many smooth structures.*

**Example.** When  $\mathbf{c}$  arises from an almost-complex structure  $J$  on  $M$ , and satisfies  $n_{\mathbf{c}}(M) \neq 0 \in \mathbb{Z}_2$ , then  $c_1^{\mathbb{R}}(M, J)$  is a monopole class.

When  $J$  is integrable and  $b_1$  even, we saw last time that  $c_1(M, J)$  is therefore a monopole class.

On  $K3$ , only monopole class is  $0 \in H^2(M, \mathbb{Z})$ .

Different for any Kodaira “homotopy  $K3$ .”

**Proposition.** *The topological manifold  $|K3|$  admits infinitely many smooth structures. Exactly one of these admits an Einstein metric.*

**Theorem** (Hitchin-Thorpe Inequality). *If smooth compact oriented  $M^4$  admits Einstein  $g$ , then*

$$(2\chi + 3\tau)(M) \geq 0,$$

**Theorem** (Hitchin-Thorpe Inequality). *If smooth compact oriented  $M^4$  admits Einstein  $g$ , then*

$$(2\chi + 3\tau)(M) \geq 0,$$

*with equality only if  $(M, g)$  is finitely covered by flat  $T^4$  or Calabi-Yau  $K3$ .*

**Example.** When  $\mathbf{c}$  arises from an almost-complex structure  $J$  on  $M$ , and satisfies  $n_{\mathbf{c}}(M) \neq 0 \in \mathbb{Z}_2$ , then  $c_1^{\mathbb{R}}(M, J)$  is a monopole class.

When  $J$  is integrable and  $b_1$  even, we saw last time that  $c_1(M, J)$  is therefore a monopole class.

On  $K3$ , only monopole class is  $0 \in H^2(M, \mathbb{Z})$ .

Different for any Kodaira “homotopy  $K3$ .”

**Proposition.** *The topological manifold  $|K3|$  admits infinitely many smooth structures. Exactly one of these admits an Einstein metric.*

The finiteness of the set of monopole classes also allows us to make the following definition:

Definition. *Let*

$$\mathfrak{e} = \{\text{monopole classes}\}.$$

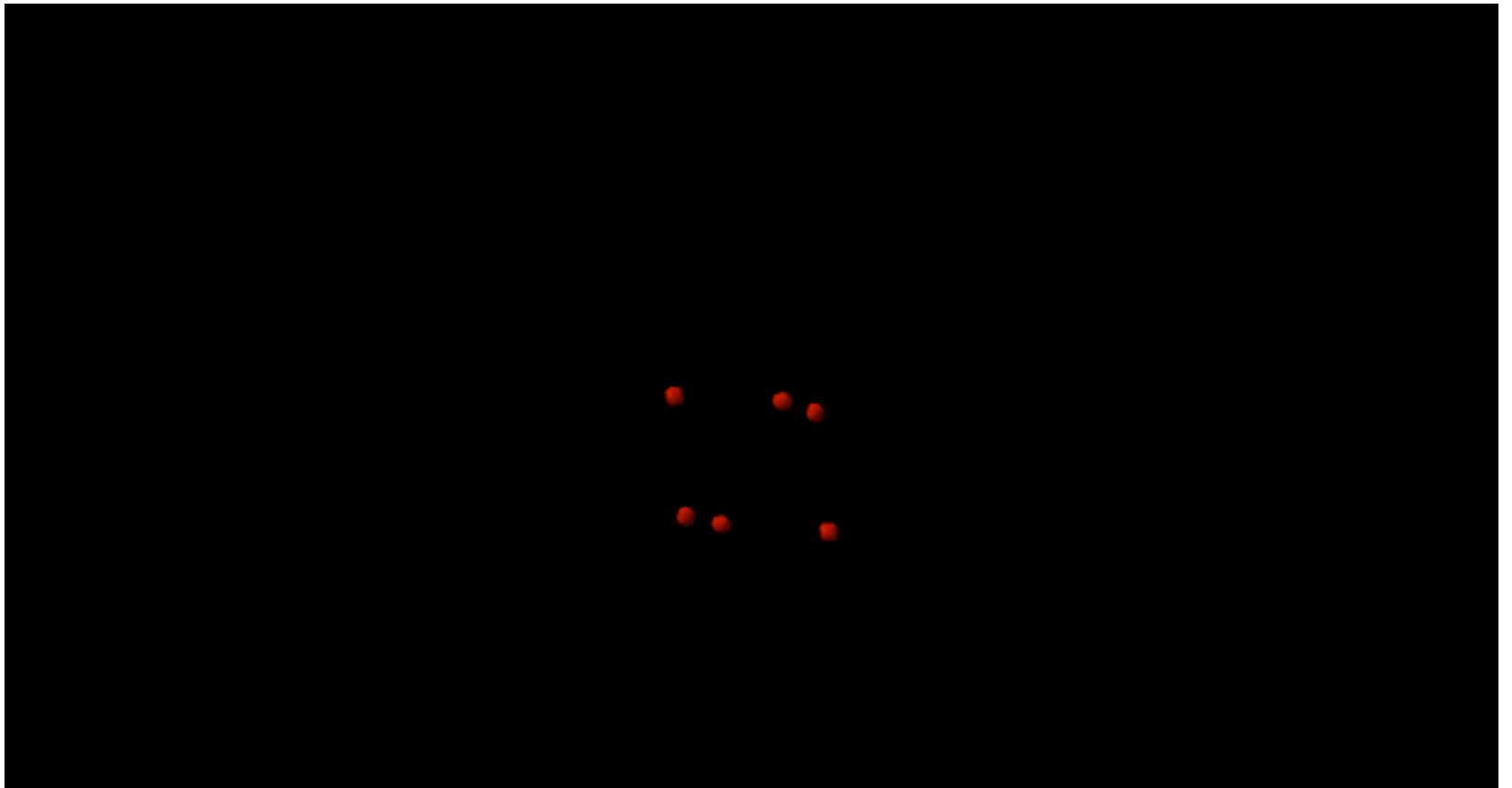

**Definition.** *Let*

$$\mathfrak{E} = \{\text{monopole classes}\}.$$

*If*  $\mathfrak{E} \neq \emptyset$ , *let*

$$\text{Hull}(\mathfrak{E}) = \text{convex hull of } \mathfrak{E} \subset H^2(M, \mathbb{R})$$

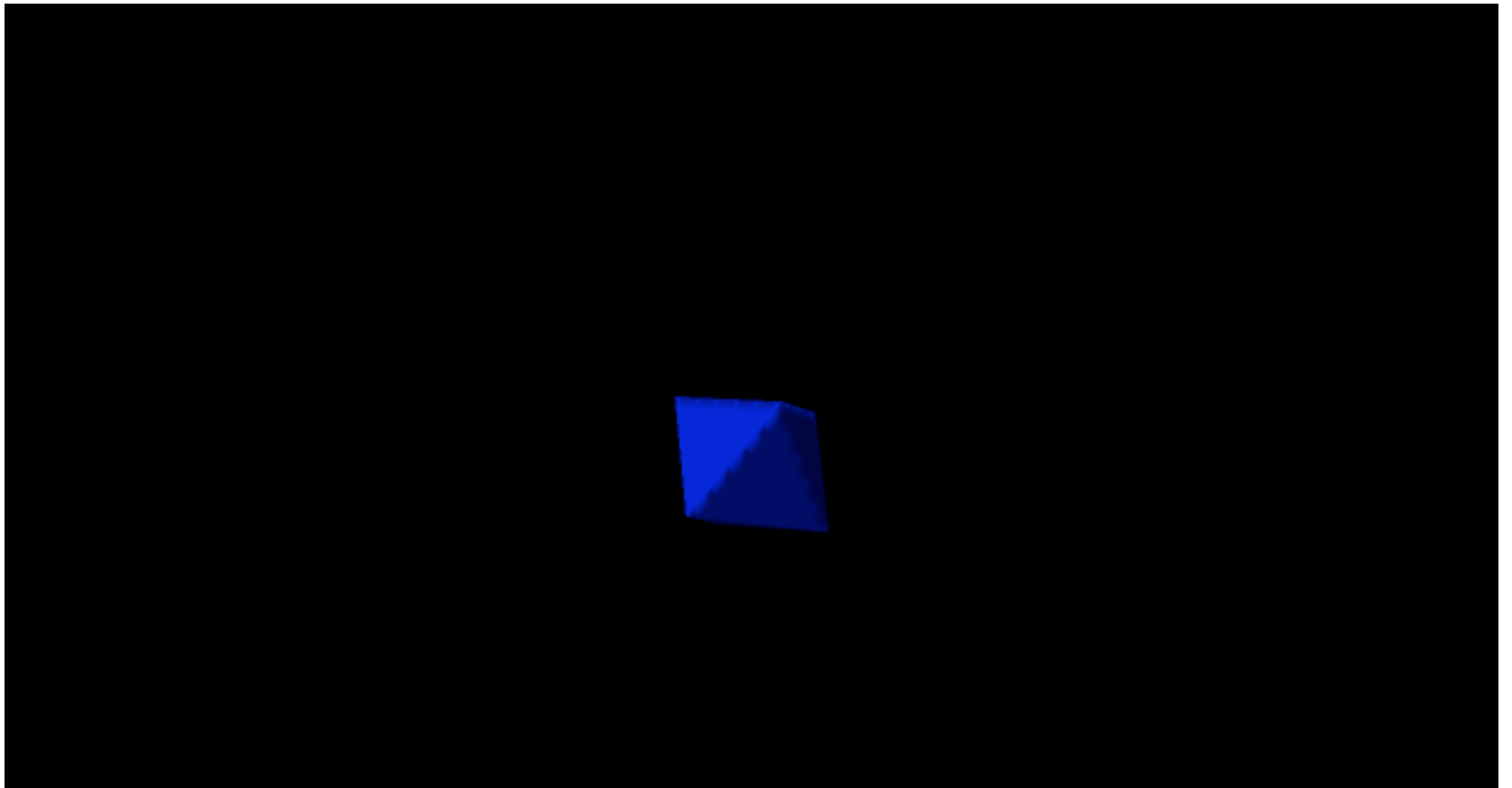

**Definition.** *Let*

$$\mathfrak{E} = \{\text{monopole classes}\}.$$

*If  $\mathfrak{E} \neq \emptyset$ , let*

$$\text{Hull}(\mathfrak{E}) = \text{convex hull of } \mathfrak{E} \subset H^2(M, \mathbb{R})$$

*and set*

$$\beta^2(M) = \max \{v \bullet v \mid v \in \text{Hull}(\mathfrak{E})\}$$

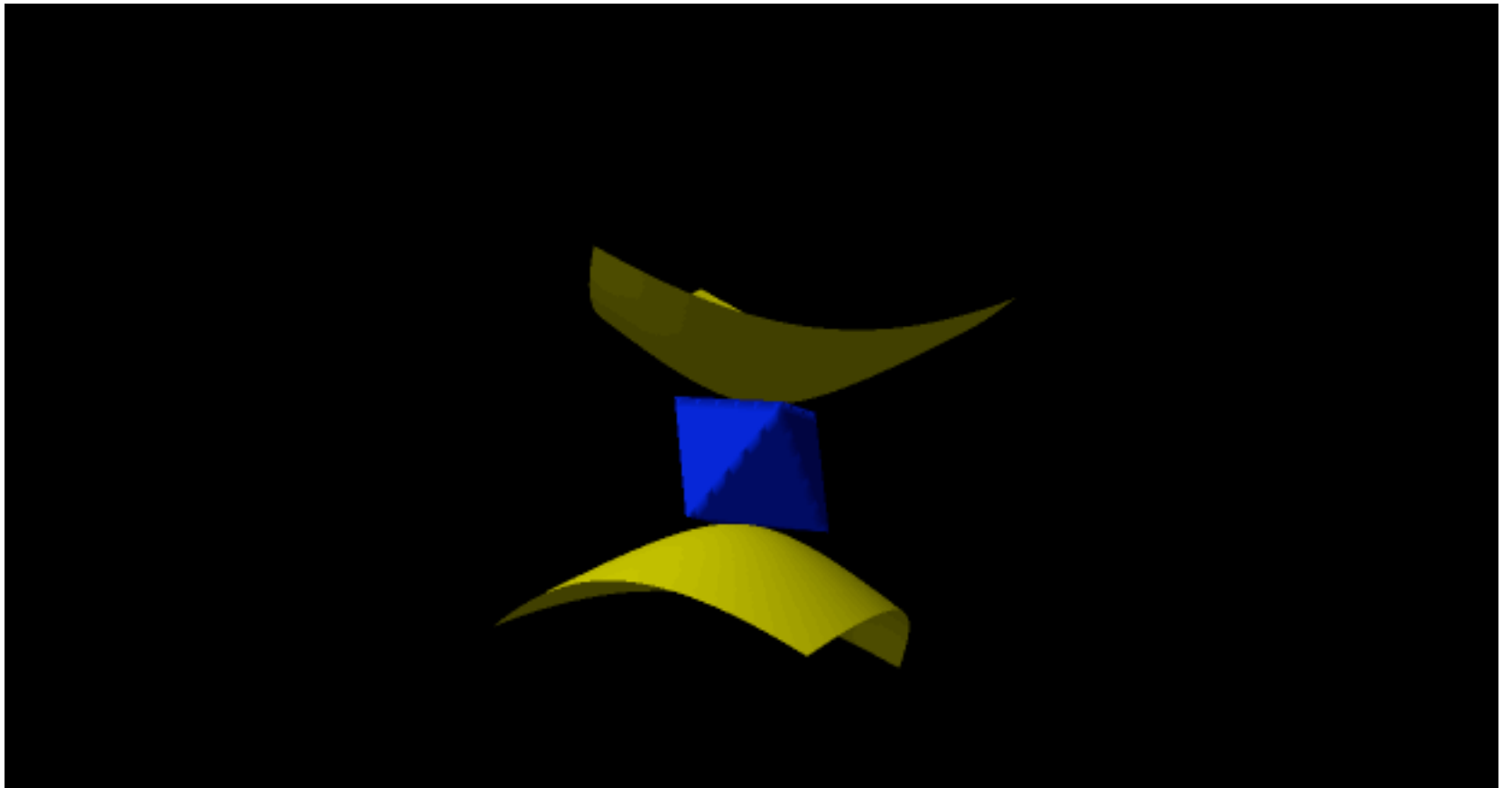

**Definition.** *Let*

$$\mathfrak{E} = \{\text{monopole classes}\}.$$

*If  $\mathfrak{E} \neq \emptyset$ , let*

$$\text{Hull}(\mathfrak{E}) = \text{convex hull of } \mathfrak{E} \subset H^2(M, \mathbb{R})$$

*and set*

$$\beta^2(M) = \max \{v \bullet v \mid v \in \text{Hull}(\mathfrak{E})\}$$

*If  $\mathfrak{E} = \emptyset$ , set  $\beta^2(M) = 0$ .*

**Definition.** *Let*

$$\mathfrak{E} = \{\text{monopole classes}\}.$$

*If  $\mathfrak{E} \neq \emptyset$ , let*

$$\text{Hull}(\mathfrak{E}) = \text{convex hull of } \mathfrak{E} \subset H^2(M, \mathbb{R})$$

*and set*

$$\beta^2(M) = \max \{v \bullet v \mid v \in \text{Hull}(\mathfrak{E})\}$$

*If  $\mathfrak{E} = \emptyset$ , set  $\beta^2(M) = 0$ .*

*If  $\mathfrak{E} \neq \emptyset$ , reflection invariance guarantees that 0 belongs to its convex hull.*

**Definition.** *Let*

$$\mathfrak{E} = \{\text{monopole classes}\}.$$

*If  $\mathfrak{E} \neq \emptyset$ , let*

$$\text{Hull}(\mathfrak{E}) = \text{convex hull of } \mathfrak{E} \subset H^2(M, \mathbb{R})$$

*and set*

$$\beta^2(M) = \max \{v \bullet v \mid v \in \text{Hull}(\mathfrak{E})\}$$

*If  $\mathfrak{E} = \emptyset$ , set  $\beta^2(M) = 0$ .*

If  $\mathfrak{E} \neq \emptyset$ , reflection invariance guarantees that 0 belongs to its convex hull. So we automatically have

$$\beta^2(M) \geq 0.$$

**Definition.** Let

$$\mathfrak{E} = \{\text{monopole classes}\}.$$

If  $\mathfrak{E} \neq \emptyset$ , let

$$\text{Hull}(\mathfrak{E}) = \text{convex hull of } \mathfrak{E} \subset H^2(M, \mathbb{R})$$

and set

$$\beta^2(M) = \max \{v \bullet v \mid v \in \text{Hull}(\mathfrak{E})\}$$

If  $\mathfrak{E} = \emptyset$ , set  $\beta^2(M) = 0$ .

If  $\mathfrak{E} \neq \emptyset$ , reflection invariance guarantees that 0 belongs to its convex hull. So we automatically have

$$\beta^2(M) \geq 0.$$

We may therefore set  $\beta(M) := \sqrt{\beta^2(M)}$ .

**Theorem** (Curvature Estimates). *For any  $C^2$  Riemannian metric  $g$*

**Theorem** (Curvature Estimates). *For any  $C^2$  Riemannian metric  $g$  on any smooth compact oriented 4-manifold  $M$  with  $b_+ \geq 2$ ,*

**Theorem (Curvature Estimates).** *For any  $C^2$  Riemannian metric  $g$  on any smooth compact oriented 4-manifold  $M$  with  $b_+ \geq 2$ , the following curvature bounds are satisfied:*

**Theorem (Curvature Estimates).** *For any  $C^2$  Riemannian metric  $g$  on any smooth compact oriented 4-manifold  $M$  with  $b_+ \geq 2$ , the following curvature bounds are satisfied:*

$$\int_M s^2 d\mu_g \geq 32\pi^2 \beta^2(M)$$

**Theorem (Curvature Estimates).** *For any  $C^2$  Riemannian metric  $g$  on any smooth compact oriented 4-manifold  $M$  with  $b_+ \geq 2$ , the following curvature bounds are satisfied:*

$$\int_M s^2 d\mu_g \geq 32\pi^2 \beta^2(M)$$
$$\int_M \left( s - \sqrt{6}|W_+| \right)^2 d\mu_g \geq 72\pi^2 \beta^2(M)$$

**Theorem (Curvature Estimates).** *For any  $C^2$  Riemannian metric  $g$  on any smooth compact oriented 4-manifold  $M$  with  $b_+ \geq 2$ , the following curvature bounds are satisfied:*

$$\int_M s^2 d\mu_g \geq 32\pi^2 \beta^2(M)$$

$$\int_M \left( s - \sqrt{6}|W_+| \right)^2 d\mu_g \geq 72\pi^2 \beta^2(M)$$

Key observation: If  $v \in \text{Hull}(\mathfrak{e})$ , then  $\forall g \exists a \in \mathfrak{e}$  such that

$$(a^+)^2 \geq (v^+)^2 \geq v^2.$$

**Theorem (Curvature Estimates).** *For any  $C^2$  Riemannian metric  $g$  on any smooth compact oriented 4-manifold  $M$  with  $b_+ \geq 2$ , the following curvature bounds are satisfied:*

$$\int_M s^2 d\mu_g \geq 32\pi^2 \beta^2(M)$$

$$\int_M \left( s - \sqrt{6}|W_+| \right)^2 d\mu_g \geq 72\pi^2 \beta^2(M)$$

**Key observation:** If  $v \in \text{Hull}(\mathfrak{e})$ , then  $\forall g \exists a \in \mathfrak{e}$  such that

$$(a^+)^2 \geq (v^+)^2 \geq v^2.$$

Now take  $v$  to maximize  $v^2 := v \bullet v$  on  $\text{Hull}(\mathfrak{e})$ .

**Theorem (Curvature Estimates).** *For any  $C^2$  Riemannian metric  $g$  on any smooth compact oriented 4-manifold  $M$  with  $b_+ \geq 2$ , the following curvature bounds are satisfied:*

$$\int_M s^2 d\mu_g \geq 32\pi^2 \beta^2(M)$$
$$\int_M \left( s - \sqrt{6}|W_+| \right)^2 d\mu_g \geq 72\pi^2 \beta^2(M)$$

**Theorem (Curvature Estimates).** *For any  $C^2$  Riemannian metric  $g$  on any smooth compact oriented 4-manifold  $M$  with  $b_+ \geq 2$ , the following curvature bounds are satisfied:*

$$\int_M s^2 d\mu_g \geq 32\pi^2 \beta^2(M)$$

$$\int_M \left( s - \sqrt{6}|W_+| \right)^2 d\mu_g \geq 72\pi^2 \beta^2(M)$$

Moreover, if  $\beta^2(M) \neq 0$ , equality holds in either case iff  $(M, g)$  is a *Kähler-Einstein* manifold with  $s < 0$ .

**Theorem (Curvature Estimates).** *For any  $C^2$  Riemannian metric  $g$  on any smooth compact oriented 4-manifold  $M$  with  $b_+ \geq 2$ , the following curvature bounds are satisfied:*

$$\int_M s^2 d\mu_g \geq 32\pi^2 \beta^2(M)$$

$$\int_M \left( s - \sqrt{6}|W_+| \right)^2 d\mu_g \geq 72\pi^2 \beta^2(M)$$

Moreover, if  $\beta^2(M) \neq 0$ , equality holds in either case iff  $(M, g)$  is a *Kähler-Einstein* manifold with  $s < 0$ .

The equality case intimately reflects the following. . .

**Example** If  $X$  is a minimal complex surface with  $b_+ > 1$ , and if

$$M = X \# \ell \overline{\mathbb{C}\mathbb{P}_2}$$

then

$$\beta^2(M) = c_1^2(X)$$

because every basic class is a monopole class.  $\diamond$

**Theorem (Curvature Estimates).** *For any  $C^2$  Riemannian metric  $g$  on any smooth compact oriented 4-manifold  $M$  with  $b_+ \geq 2$ , the following curvature bounds are satisfied:*

$$\int_M s^2 d\mu_g \geq 32\pi^2 \beta^2(M)$$

$$\int_M \left( s - \sqrt{6}|W_+| \right)^2 d\mu_g \geq 72\pi^2 \beta^2(M)$$

Moreover, if  $\beta^2(M) \neq 0$ , equality holds in either case iff  $(M, g)$  is a *Kähler-Einstein* manifold with  $s < 0$ .

$$\frac{1}{4\pi^2} \int_M \left( \frac{s^2}{24} + 2|W_+|^2 \right) d\mu_g$$

Second curvature estimate implies

$$\frac{1}{4\pi^2} \int_M \left( \frac{s^2}{24} + 2|W_+|^2 \right) d\mu_g \geq \frac{2}{3} \beta^2(M)$$

Second curvature estimate implies

$$\frac{1}{4\pi^2} \int_M \left( \frac{s^2}{24} + 2|W_+|^2 \right) d\mu_g \geq \frac{2}{3} \beta^2(M)$$

Hence:

**Theorem.** *Let  $M$  be a smooth compact oriented 4-manifold with  $b_+(M) \geq 2$ .*

Second curvature estimate implies

$$\frac{1}{4\pi^2} \int_M \left( \frac{s^2}{24} + 2|W_+|^2 \right) d\mu_g \geq \frac{2}{3} \beta^2(M)$$

Hence:

**Theorem.** *Let  $M$  be a smooth compact oriented 4-manifold with  $b_+(M) \geq 2$ . If  $M$  admits an Einstein metric  $g$ ,*

Second curvature estimate implies

$$\frac{1}{4\pi^2} \int_M \left( \frac{s^2}{24} + 2|W_+|^2 \right) d\mu_g \geq \frac{2}{3} \beta^2(M)$$

Hence:

**Theorem.** *Let  $M$  be a smooth compact oriented 4-manifold with  $b_+(M) \geq 2$ . If  $M$  admits an Einstein metric  $g$ , then*

$$(2\chi + 3\tau)(M) \geq \frac{2}{3} \beta^2(M)$$

Second curvature estimate implies

$$\frac{1}{4\pi^2} \int_M \left( \frac{s^2}{24} + 2|W_+|^2 \right) d\mu_g \geq \frac{2}{3} \beta^2(M)$$

Hence:

**Theorem.** *Let  $M$  be a smooth compact oriented 4-manifold with  $b_+(M) \geq 2$ . If  $M$  admits an Einstein metric  $g$ , then*

$$(2\chi + 3\tau)(M) \geq \frac{2}{3} \beta^2(M)$$

*with equality only if both sides vanish,*

Second curvature estimate implies

$$\frac{1}{4\pi^2} \int_M \left( \frac{s^2}{24} + 2|W_+|^2 \right) d\mu_g \geq \frac{2}{3} \beta^2(M)$$

Hence:

**Theorem.** *Let  $M$  be a smooth compact oriented 4-manifold with  $b_+(M) \geq 2$ . If  $M$  admits an Einstein metric  $g$ , then*

$$(2\chi + 3\tau)(M) \geq \frac{2}{3} \beta^2(M)$$

*with equality only if both sides vanish, in which case  $g$  must be hyper-Kähler, and  $M$  must be diffeomorphic to either  $K3$  or  $T^4$ .*

**Example** If  $X$  is a minimal complex surface with  $b_+ > 1$ , and if

$$M = X \# \ell \overline{\mathbb{C}P}_2$$

then

$$\beta^2(M) = c_1^2(X)$$

because every basic class is a monopole class.  $\diamond$

Indeed, since every basic class  $\in \mathfrak{E}$ , one can show that  $c_1(X) \in \text{Hull}(\mathfrak{E})$ , and hence

$$\beta^2(M) \geq c_1^2(X).$$

**Example** If  $X$  is a minimal complex surface with  $b_+ > 1$ , and if

$$M = X \# \ell \overline{\mathbb{C}\mathbb{P}_2}$$

then

$$\beta^2(M) = c_1^2(X)$$

because every basic class is a monopole class.  $\diamond$

Indeed, since every basic class  $\in \mathfrak{C}$ , one can show that  $c_1(X) \in \text{Hull}(\mathfrak{C})$ , and hence

$$\beta^2(M) \geq c_1^2(X).$$

But one can also construct explicit sequences with

$$\frac{1}{32\pi^2} \int_M s_{g_j}^2 d\mu_{g_j} \rightarrow c_1^2(X).$$

**Example** If  $X$  is a minimal complex surface with  $b_+ > 1$ , and if

$$M = X \# \ell \overline{\mathbb{C}P}_2$$

then

$$\beta^2(M) = c_1^2(X)$$

because every basic class is a monopole class.  $\diamond$

Indeed, since every basic class  $\in \mathfrak{E}$ , one can show that  $c_1(X) \in \text{Hull}(\mathfrak{E})$ , and hence

$$\beta^2(M) \geq c_1^2(X).$$

So we also have

$$c_1^2(X) \geq \beta^2(M).$$

**Example** If  $X$  is a minimal complex surface with  $b_+ > 1$ , and if

$$M = X \# \ell \overline{\mathbb{C}P}_2$$

then

$$\beta^2(M) = c_1^2(X)$$

because every basic class is a monopole class.  $\diamond$

**Example** If  $X$  is a minimal complex surface with  $b_+ > 1$ , and if

$$M = X \# \ell \overline{\mathbb{C}\mathbb{P}_2}$$

then

$$\beta^2(M) = c_1^2(X)$$

because every basic class is a monopole class.  $\diamond$

**Example** Let  $X$ ,  $Y$ , and  $Z$  be minimal simply-connected complex surfaces  $b_+ \equiv 3 \pmod{4}$ , and set

$$M = X \# Y \# Z \# \ell \overline{\mathbb{C}\mathbb{P}_2}.$$

$\diamond$

**Example** If  $X$  is a minimal complex surface with  $b_+ > 1$ , and if

$$M = X \# \ell \overline{\mathbb{C}\mathbb{P}_2}$$

then

$$\beta^2(M) = c_1^2(X)$$

because every basic class is a monopole class.  $\diamond$

**Example** Let  $X$ ,  $Y$ , and  $Z$  be minimal simply-connected complex surfaces  $b_+ \equiv 3 \pmod{4}$ , and set

$$M = X \# Y \# Z \# \ell \overline{\mathbb{C}\mathbb{P}_2}.$$

Bauer-Furuta invariant allows one to show that

$$\beta^2(M) = c_1^2(X) + c_1^2(Y) + c_1^2(Z).$$



**Example** If  $X$  is a minimal complex surface with  $b_+ > 1$ , and if

$$M = X \# \ell \overline{\mathbb{C}\mathbb{P}_2}$$

then

$$\beta^2(M) = c_1^2(X)$$

because every basic class is a monopole class.  $\diamond$

**Example** Let  $X$ ,  $Y$ , and  $Z$  be minimal simply-connected complex surfaces  $b_+ \equiv 3 \pmod{4}$ , and set

$$M = X \# Y \# Z \# \ell \overline{\mathbb{C}\mathbb{P}_2}.$$

Bauer-Furuta invariant allows one to show that

$$\beta^2(M) = c_1^2(X) + c_1^2(Y) + c_1^2(Z).$$

in conjunction with a construction of minimizing sequences of metrics  $g_j$  on this manifold.  $\diamond$

**Theorem.** *Let  $X$ ,  $Y$ , and  $Z$  be compact oriented simply connected symplectic 4-manifolds with  $b_+ \equiv 3 \pmod{4}$ . Then, with respect to the canonical isomorphisms*

$$H^2(X \# Y, \mathbb{Z}) = H^2(X, \mathbb{Z}) \oplus H^2(Y, \mathbb{Z})$$

$$H^2(X \# Y \# Z, \mathbb{Z}) = H^2(X, \mathbb{Z}) \oplus H^2(Y, \mathbb{Z}) \oplus H^2(Z, \mathbb{Z}),$$

*the cohomology classes*

$$\pm c_1(X) \pm c_1(Y) \in H^2(X, \mathbb{Z}) \oplus H^2(Y, \mathbb{Z})$$

$$\pm c_1(X) \pm c_1(Y) \pm c_1(Z) \in H^2(X, \mathbb{Z}) \oplus H^2(Y, \mathbb{Z}) \oplus H^2(Z, \mathbb{Z})$$

*are monopole classes on  $X \# Y$  and  $X \# Y \# Z$ , respectively. Here the  $\pm$  signs are arbitrary, and independent of one another.*

**Theorem.** *Let  $(m, n)$  be a pair of natural numbers*

**Theorem.** *Let  $(m, n)$  be a pair of natural numbers with  $m \equiv 1 \pmod{4}$  and  $m \geq 9$ .*

**Theorem.** *Let  $(m, n)$  be a pair of natural numbers with  $m \equiv 1 \pmod{4}$  and  $m \geq 9$ . If*

$$n > \frac{7}{3}m + 12,$$

**Theorem.** *Let  $(m, n)$  be a pair of natural numbers with  $m \equiv 1 \pmod{4}$  and  $m \geq 9$ . If*

$$n > \frac{7}{3}m + 12,$$

*there are infinitely many*

**Theorem.** *Let  $(m, n)$  be a pair of natural numbers with  $m \equiv 1 \pmod{4}$  and  $m \geq 9$ . If*

$$n > \frac{7}{3}m + 12,$$

*there are infinitely many distinct smooth structures on  $m\mathbb{C}P_2 \# n\overline{\mathbb{C}P_2}$*

**Theorem.** *Let  $(m, n)$  be a pair of natural numbers with  $m \equiv 1 \pmod{4}$  and  $m \geq 9$ . If*

$$n > \frac{7}{3}m + 12,$$

*there are infinitely many distinct smooth structures on  $m\mathbb{C}P_2 \# n\overline{\mathbb{C}P_2}$  for which no Einstein metric can exist.*

**Theorem.** *Let  $(m, n)$  be a pair of natural numbers with  $m \equiv 1 \pmod{4}$  and  $m \geq 9$ . If*

$$n > \frac{7}{3}m + 12,$$

*there are infinitely many distinct smooth structures on  $m\mathbb{C}P_2 \# n\overline{\mathbb{C}P_2}$  for which no Einstein metric can exist.*

Here the smooth manifolds are constructed as

$$X \# Y_\ell \# Z \# k\overline{\mathbb{C}P_2},$$

**Theorem.** *Let  $(m, n)$  be a pair of natural numbers with  $m \equiv 1 \pmod{4}$  and  $m \geq 9$ . If*

$$n > \frac{7}{3}m + 12,$$

*there are infinitely many distinct smooth structures on  $m\mathbb{C}P_2 \# n\overline{\mathbb{C}P_2}$  for which no Einstein metric can exist.*

Here the smooth manifolds are constructed as

$$X \# Y_\ell \# Z \# k\overline{\mathbb{C}P_2},$$

where  $Y_\ell$  are the homotopy  $K3$  surfaces we previously discussed,

**Theorem.** *Let  $(m, n)$  be a pair of natural numbers with  $m \equiv 1 \pmod{4}$  and  $m \geq 9$ . If*

$$n > \frac{7}{3}m + 12,$$

*there are infinitely many distinct smooth structures on  $m\mathbb{C}P_2 \# n\overline{\mathbb{C}P_2}$  for which no Einstein metric can exist.*

Here the smooth manifolds are constructed as

$$X \# Y_\ell \# Z \# k\overline{\mathbb{C}P_2},$$

where  $Y_\ell$  are the homotopy  $K3$  surfaces we previously discussed, and  $X$  and  $Z$  are suitable simply connected symplectic 4-manifolds

**Theorem.** *Let  $(m, n)$  be a pair of natural numbers with  $m \equiv 1 \pmod{4}$  and  $m \geq 9$ . If*

$$n > \frac{7}{3}m + 12,$$

*there are infinitely many distinct smooth structures on  $m\mathbb{C}P_2 \# n\overline{\mathbb{C}P_2}$  for which no Einstein metric can exist.*

Here the smooth manifolds are constructed as

$$X \# Y_\ell \# Z \# k\overline{\mathbb{C}P_2},$$

where  $Y_\ell$  are the homotopy  $K3$  surfaces we previously discussed, and  $X$  and  $Z$  are suitable simply connected symplectic 4-manifolds for each  $(m, n)$ .

**Theorem.** *Let  $(m, n)$  be a pair of natural numbers with  $m \equiv 1 \pmod{4}$  and  $m \geq 9$ . If*

$$n > \frac{7}{3}m + 12,$$

*there are infinitely many distinct smooth structures on  $m\mathbb{C}P_2 \# n\overline{\mathbb{C}P_2}$  for which no Einstein metric can exist.*

Here the smooth manifolds are constructed as

$$X \# Y_\ell \# Z \# k\overline{\mathbb{C}P_2},$$

where  $Y_\ell$  are the homotopy  $K3$  surfaces we previously discussed, and  $X$  and  $Z$  are suitable simply connected symplectic 4-manifolds for each  $(m, n)$ .

$$BW(X \# Y_\ell \# Z \# k\overline{\mathbb{C}P_2}) \geq 2\ell \rightarrow +\infty$$

**Example.** For any integer  $p \geq 6$  with

$$p \equiv 2 \pmod{4},$$

set  $m = p^2 - 3p + 3$  and  $n = 3p^2 - 3p + 1$ . We then have  $m \equiv 1 \pmod{4}$ ,  $m \geq 9$ , and  $n > \frac{7}{3}m + 12$ .

**Example.** For any integer  $p \geq 6$  with

$$p \equiv 2 \pmod{4},$$

set  $m = p^2 - 3p + 3$  and  $n = 3p^2 - 3p + 1$ . We then have  $m \equiv 1 \pmod{4}$ ,  $m \geq 9$ , and  $n > \frac{7}{3}m + 12$ .

**Theorem** asserts that there are infinitely many smooth structures on  $m\mathbb{C}P_2 \# n\overline{\mathbb{C}P}_2$  for which no Einstein metrics exists.

**Example.** For any integer  $p \geq 6$  with

$$p \equiv 2 \pmod{4},$$

set  $m = p^2 - 3p + 3$  and  $n = 3p^2 - 3p + 1$ . We then have  $m \equiv 1 \pmod{4}$ ,  $m \geq 9$ , and  $n > \frac{7}{3}m + 12$ .

**Theorem** asserts that there are infinitely many smooth structures on  $m\mathbb{C}P_2 \# n\overline{\mathbb{C}P}_2$  for which no Einstein metrics exists.

But this homeotype is also realizable by the double branched cover of  $\mathbb{C}P_2$ , ramified over a smooth curve of degree  $2p$ .

**Example.** For any integer  $p \geq 6$  with

$$p \equiv 2 \pmod{4},$$

set  $m = p^2 - 3p + 3$  and  $n = 3p^2 - 3p + 1$ . We then have  $m \equiv 1 \pmod{4}$ ,  $m \geq 9$ , and  $n > \frac{7}{3}m + 12$ .

**Theorem** asserts that there are infinitely many smooth structures on  $m\mathbb{C}P_2 \# n\overline{\mathbb{C}P}_2$  for which no Einstein metrics exists.

But this homeotype is also realizable by the double branched cover of  $\mathbb{C}P_2$ , ramified over a smooth curve of degree  $2p$ .

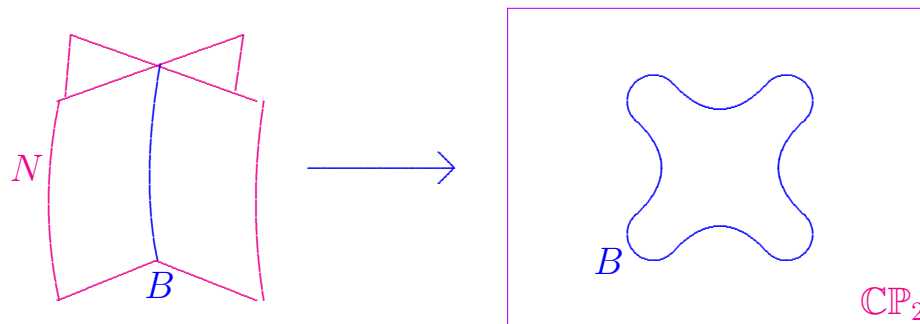

**Example.** For any integer  $p \geq 6$  with

$$p \equiv 2 \pmod{4},$$

set  $m = p^2 - 3p + 3$  and  $n = 3p^2 - 3p + 1$ . We then have  $m \equiv 1 \pmod{4}$ ,  $m \geq 9$ , and  $n > \frac{7}{3}m + 12$ .

**Theorem** asserts that there are infinitely many smooth structures on  $m\mathbb{C}P_2 \# n\overline{\mathbb{C}P_2}$  for which no Einstein metrics exists.

But this homeotype is also realizable by the double branched cover of  $\mathbb{C}P_2$ , ramified over a smooth curve of degree  $2p$ .

This complex surface has ample canonical line bundle so Aubin/Yau theorem implies that it admits an Einstein metric (which can be constructed so as to also be Kähler).

Existence depends on diffeotype!

**Example.** For any integer  $p \geq 6$  with

$$p \equiv 2 \pmod{4},$$

set  $m = p^2 - 3p + 3$  and  $n = 3p^2 - 3p + 1$ . We then have  $m \equiv 1 \pmod{4}$ ,  $m \geq 9$ , and  $n > \frac{7}{3}m + 12$ .

**Theorem** asserts that there are infinitely many smooth structures on  $m\mathbb{C}P_2 \# n\overline{\mathbb{C}P_2}$  for which no Einstein metrics exists.

But this homeotype is also realizable by the double branched cover of  $\mathbb{C}P_2$ , ramified over a smooth curve of degree  $2p$ .

This complex surface has ample canonical line bundle so Aubin/Yau theorem implies that it admits an Einstein metric (which can be constructed so as to also be Kähler).

Existence depends on diffeotype!

*Intermission*

Our discussion of Einstein metrics has largely concerned settings where we automatically have  $\lambda \leq 0$ .

Our discussion of Einstein metrics has largely concerned settings where we automatically have  $\lambda \leq 0$ .

We now turn to the  $\lambda > 0$  case.

**Theorem.** *Suppose that  $M$  is a smooth compact oriented 4-manifold which admits a complex structure  $J$ .*

**Theorem.** *Suppose that  $M$  is a smooth compact oriented 4-manifold which admits a complex structure  $J$ . Then  $M$  also admits an (unrelated) Einstein metric  $g$  with  $\lambda > 0$*

**Theorem.** Suppose that  $M$  is a smooth compact oriented 4-manifold which admits a complex structure  $J$ . Then  $M$  also admits an (unrelated) Einstein metric  $g$  with  $\lambda > 0$

$$\iff M \approx \left\{ \begin{array}{l} \mathbb{C}P_2 \# k \overline{\mathbb{C}P_2}, \end{array} \right.$$

**Theorem.** Suppose that  $M$  is a smooth compact oriented 4-manifold which admits a complex structure  $J$ . Then  $M$  also admits an (unrelated) Einstein metric  $g$  with  $\lambda > 0$

$$\iff M \approx \begin{cases} \mathbb{C}P_2 \# k \overline{\mathbb{C}P_2}, & 0 \leq k \leq 8, \end{cases}$$

**Theorem.** Suppose that  $M$  is a smooth compact oriented 4-manifold which admits a complex structure  $J$ . Then  $M$  also admits an (unrelated) Einstein metric  $g$  with  $\lambda > 0$

$$\iff M \approx \begin{cases} \mathbb{C}P_2 \# k \overline{\mathbb{C}P_2}, & 0 \leq k \leq 8, \\ \text{or} \\ S^2 \times S^2 \end{cases}$$

**Theorem.** Suppose that  $M$  is a smooth compact oriented 4-manifold which admits a complex structure  $J$ . Then  $M$  also admits an (unrelated) Einstein metric  $g$  with  $\lambda > 0$

$$\iff M \approx \begin{cases} \mathbb{C}P_2 \#^k \overline{\mathbb{C}P_2}, & 0 \leq k \leq 8, \\ \text{or} \\ S^2 \times S^2 \end{cases}$$

Proof that there no other candidates:

**Theorem.** Suppose that  $M$  is a smooth compact oriented 4-manifold which admits a complex structure  $J$ . Then  $M$  also admits an (unrelated) Einstein metric  $g$  with  $\lambda > 0$

$$\iff M \approx \begin{cases} \mathbb{C}P_2 \#^k \overline{\mathbb{C}P_2}, & 0 \leq k \leq 8, \\ \text{or} \\ S^2 \times S^2 \end{cases}$$

Proof that there no other candidates:

- Hitchin-Thorpe:  $c_1^2(M) = (2\chi + 3\tau)(M) > 0$ .

**Theorem.** Suppose that  $M$  is a smooth compact oriented 4-manifold which admits a complex structure  $J$ . Then  $M$  also admits an (unrelated) Einstein metric  $g$  with  $\lambda > 0$

$$\iff M \approx \begin{cases} \mathbb{C}P_2 \#^k \overline{\mathbb{C}P_2}, & 0 \leq k \leq 8, \\ \text{or} \\ S^2 \times S^2 \end{cases}$$

Proof that there no other candidates:

- Hitchin-Thorpe:  $c_1^2(M) = (2\chi + 3\tau)(M) > 0$ .
- SW:  $\exists$  metric  $g$  with  $s > 0 \implies \text{Kod} = -\infty$ .

**Theorem.** Suppose that  $M$  is a smooth compact oriented 4-manifold which admits a complex structure  $J$ . Then  $M$  also admits an (unrelated) Einstein metric  $g$  with  $\lambda > 0$

$$\iff M \approx \begin{cases} \mathbb{C}P_2 \#^k \overline{\mathbb{C}P_2}, & 0 \leq k \leq 8, \\ \text{or} \\ S^2 \times S^2 \end{cases}$$

**Theorem.** Suppose that  $M$  is a smooth compact oriented 4-manifold which admits a complex structure  $J$ . Then  $M$  also admits an (unrelated) Einstein metric  $g$  with  $\lambda > 0$

$$\iff M \approx \begin{cases} \mathbb{C}P_2 \# k \overline{\mathbb{C}P_2}, & 0 \leq k \leq 8, \\ \text{or} \\ S^2 \times S^2 \end{cases}$$

Diffeotypes: “Del Pezzo surfaces.”

**Theorem.** Suppose that  $M$  is a smooth compact oriented 4-manifold which admits a complex structure  $J$ . Then  $M$  also admits an (unrelated) Einstein metric  $g$  with  $\lambda > 0$

$$\iff M \approx \begin{cases} \mathbb{C}P_2 \# k \overline{\mathbb{C}P_2}, & 0 \leq k \leq 8, \\ \text{or} \\ S^2 \times S^2 \end{cases}$$

Diffeotypes: “Del Pezzo surfaces.”

This provides the key to proving the converse:

**Theorem.** Suppose that  $M$  is a smooth compact oriented 4-manifold which admits a complex structure  $J$ . Then  $M$  also admits an (unrelated) Einstein metric  $g$  with  $\lambda > 0$

$$\iff M \approx \begin{cases} \mathbb{C}P_2 \# k \overline{\mathbb{C}P_2}, & 0 \leq k \leq 8, \\ \text{or} \\ S^2 \times S^2 \end{cases}$$

Diffeotypes: “Del Pezzo surfaces.”

This provides the key to proving the converse:

Each candidate admits a  $\lambda > 0$  Einstein metric!

## Del Pezzo surfaces:

$(M^4, J)$  for which  $c_1$  is a Kähler class  $[\omega]$ .

## Del Pezzo surfaces:

$(M^4, J)$  for which  $c_1$  is a Kähler class  $[\omega]$ .

Shorthand: “ $c_1 > 0$ .”

## Del Pezzo surfaces:

$(M^4, J)$  for which  $c_1$  is a Kähler class  $[\omega]$ .

Shorthand: “ $c_1 > 0$ .”

Blow-up of  $\mathbb{C}P_2$  at  $k$  distinct points,  $0 \leq k \leq 8$ ,  
in general position, or  $\mathbb{C}P_1 \times \mathbb{C}P_1$ .

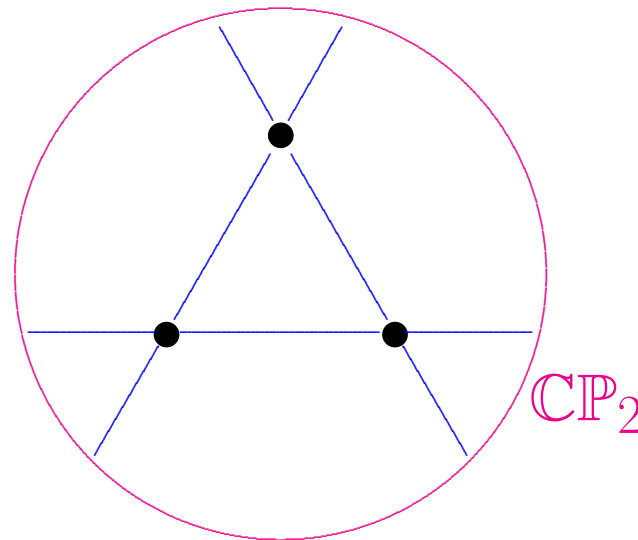

## Del Pezzo surfaces:

$(M^4, J)$  for which  $c_1$  is a Kähler class  $[\omega]$ .  
Shorthand: “ $c_1 > 0$ .”

Blow-up of  $\mathbb{C}P_2$  at  $k$  distinct points,  $0 \leq k \leq 8$ ,  
in general position, or  $\mathbb{C}P_1 \times \mathbb{C}P_1$ .

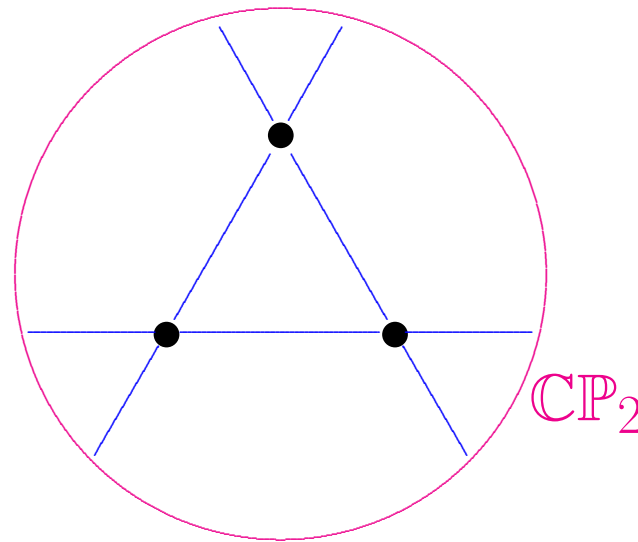

No 3 on a line,

## Del Pezzo surfaces:

$(M^4, J)$  for which  $c_1$  is a Kähler class  $[\omega]$ .  
Shorthand: “ $c_1 > 0$ .”

Blow-up of  $\mathbb{C}P_2$  at  $k$  distinct points,  $0 \leq k \leq 8$ ,  
in general position, or  $\mathbb{C}P_1 \times \mathbb{C}P_1$ .

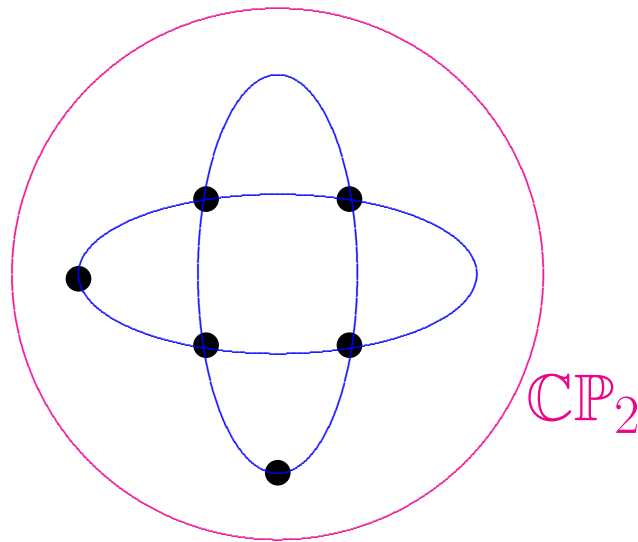

No 3 on a line, no 6 on conic,

## Del Pezzo surfaces:

$(M^4, J)$  for which  $c_1$  is a Kähler class  $[\omega]$ .  
Shorthand: “ $c_1 > 0$ .”

Blow-up of  $\mathbb{C}P_2$  at  $k$  distinct points,  $0 \leq k \leq 8$ ,  
in general position, or  $\mathbb{C}P_1 \times \mathbb{C}P_1$ .

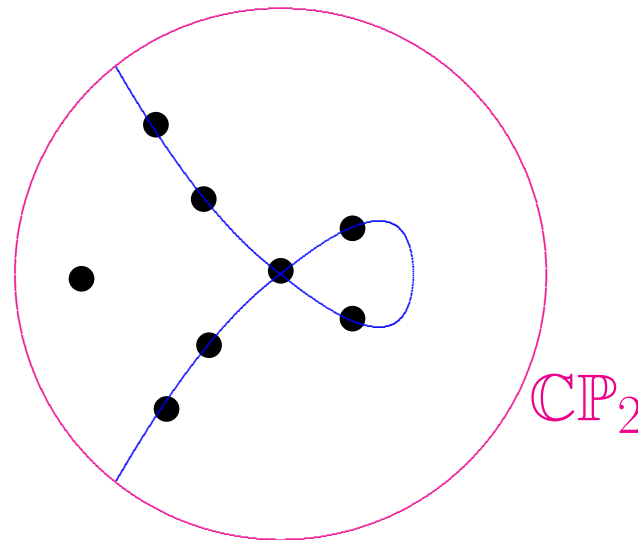

No 3 on a line, no 6 on conic, no 8 on nodal cubic.

## Del Pezzo surfaces:

$(M^4, J)$  for which  $c_1$  is a Kähler class  $[\omega]$ .

Shorthand: “ $c_1 > 0$ .”

Blow-up of  $\mathbb{C}P_2$  at  $k$  distinct points,  $0 \leq k \leq 8$ ,  
in general position, or  $\mathbb{C}P_1 \times \mathbb{C}P_1$ .

## Del Pezzo surfaces:

$(M^4, J)$  for which  $c_1$  is a Kähler class  $[\omega]$ .  
Shorthand: “ $c_1 > 0$ .”

Blow-up of  $\mathbb{C}P_2$  at  $k$  distinct points,  $0 \leq k \leq 8$ ,  
in general position, or  $\mathbb{C}P_1 \times \mathbb{C}P_1$ .

---

**Theorem.**

## Del Pezzo surfaces:

$(M^4, J)$  for which  $c_1$  is a Kähler class  $[\omega]$ .  
Shorthand: “ $c_1 > 0$ .”

Blow-up of  $\mathbb{C}P_2$  at  $k$  distinct points,  $0 \leq k \leq 8$ ,  
in general position, or  $\mathbb{C}P_1 \times \mathbb{C}P_1$ .

---

**Theorem.** *Each del Pezzo  $(M^4, J)$  admits a  $J$ -compatible*

## Del Pezzo surfaces:

$(M^4, J)$  for which  $c_1$  is a Kähler class  $[\omega]$ .  
Shorthand: “ $c_1 > 0$ .”

Blow-up of  $\mathbb{C}P_2$  at  $k$  distinct points,  $0 \leq k \leq 8$ ,  
in general position, or  $\mathbb{C}P_1 \times \mathbb{C}P_1$ .

---

**Theorem.** *Each del Pezzo  $(M^4, J)$  admits a  $J$ -compatible Hermitian,*

## Del Pezzo surfaces:

$(M^4, J)$  for which  $c_1$  is a Kähler class  $[\omega]$ .  
Shorthand: “ $c_1 > 0$ .”

Blow-up of  $\mathbb{C}P_2$  at  $k$  distinct points,  $0 \leq k \leq 8$ ,  
in general position, or  $\mathbb{C}P_1 \times \mathbb{C}P_1$ .

---

**Theorem.** *Each del Pezzo  $(M^4, J)$  admits a  $J$ -compatible Hermitian, Einstein metric,*

## Del Pezzo surfaces:

$(M^4, J)$  for which  $c_1$  is a Kähler class  $[\omega]$ .  
Shorthand: “ $c_1 > 0$ .”

Blow-up of  $\mathbb{C}P_2$  at  $k$  distinct points,  $0 \leq k \leq 8$ ,  
in general position, or  $\mathbb{C}P_1 \times \mathbb{C}P_1$ .

---

**Theorem.** *Each del Pezzo  $(M^4, J)$  admits a  $J$ -compatible Hermitian, Einstein metric, and this metric is unique*

## Del Pezzo surfaces:

$(M^4, J)$  for which  $c_1$  is a Kähler class  $[\omega]$ .  
Shorthand: “ $c_1 > 0$ .”

Blow-up of  $\mathbb{C}P_2$  at  $k$  distinct points,  $0 \leq k \leq 8$ ,  
in general position, or  $\mathbb{C}P_1 \times \mathbb{C}P_1$ .

---

**Theorem.** *Each del Pezzo  $(M^4, J)$  admits a  $J$ -compatible Hermitian, Einstein metric, and this metric is unique up to complex automorphisms and constant rescalings.*

## Del Pezzo surfaces:

$(M^4, J)$  for which  $c_1$  is a Kähler class  $[\omega]$ .  
Shorthand: “ $c_1 > 0$ .”

Blow-up of  $\mathbb{C}P_2$  at  $k$  distinct points,  $0 \leq k \leq 8$ ,  
in general position, or  $\mathbb{C}P_1 \times \mathbb{C}P_1$ .

---

**Theorem.** *Each del Pezzo  $(M^4, J)$  admits a  $J$ -compatible Hermitian, Einstein metric, and this metric is geometrically unique.*

## Del Pezzo surfaces:

$(M^4, J)$  for which  $c_1$  is a Kähler class  $[\omega]$ .  
Shorthand: “ $c_1 > 0$ .”

Blow-up of  $\mathbb{C}P_2$  at  $k$  distinct points,  $0 \leq k \leq 8$ ,  
in general position, or  $\mathbb{C}P_1 \times \mathbb{C}P_1$ .

---

**Theorem.** *Each del Pezzo  $(M^4, J)$  admits a  $J$ -compatible Hermitian, Einstein metric, and this metric is geometrically unique.*

Existence: Page

## Del Pezzo surfaces:

$(M^4, J)$  for which  $c_1$  is a Kähler class  $[\omega]$ .  
Shorthand: “ $c_1 > 0$ .”

Blow-up of  $\mathbb{C}P_2$  at  $k$  distinct points,  $0 \leq k \leq 8$ ,  
in general position, or  $\mathbb{C}P_1 \times \mathbb{C}P_1$ .

---

**Theorem.** *Each del Pezzo  $(M^4, J)$  admits a  $J$ -compatible Hermitian, Einstein metric, and this metric is geometrically unique.*

Existence: Page-Derdziński,

## Del Pezzo surfaces:

$(M^4, J)$  for which  $c_1$  is a Kähler class  $[\omega]$ .  
Shorthand: “ $c_1 > 0$ .”

Blow-up of  $\mathbb{C}P_2$  at  $k$  distinct points,  $0 \leq k \leq 8$ ,  
in general position, or  $\mathbb{C}P_1 \times \mathbb{C}P_1$ .

---

**Theorem.** *Each del Pezzo  $(M^4, J)$  admits a  $J$ -compatible Hermitian, Einstein metric, and this metric is geometrically unique.*

Existence: Page-Derdziński, Siu,

## Del Pezzo surfaces:

$(M^4, J)$  for which  $c_1$  is a Kähler class  $[\omega]$ .  
Shorthand: “ $c_1 > 0$ .”

Blow-up of  $\mathbb{C}P_2$  at  $k$  distinct points,  $0 \leq k \leq 8$ ,  
in general position, or  $\mathbb{C}P_1 \times \mathbb{C}P_1$ .

---

**Theorem.** *Each del Pezzo  $(M^4, J)$  admits a  $J$ -compatible Hermitian, Einstein metric, and this metric is geometrically unique.*

Existence: Page-Derdziński, Siu, Tian-Yau,

## Del Pezzo surfaces:

$(M^4, J)$  for which  $c_1$  is a Kähler class  $[\omega]$ .  
Shorthand: “ $c_1 > 0$ .”

Blow-up of  $\mathbb{C}P_2$  at  $k$  distinct points,  $0 \leq k \leq 8$ ,  
in general position, or  $\mathbb{C}P_1 \times \mathbb{C}P_1$ .

---

**Theorem.** *Each del Pezzo  $(M^4, J)$  admits a  $J$ -compatible Hermitian, Einstein metric, and this metric is geometrically unique.*

Existence: Page-Derdziński, Siu, Tian-Yau, Tian,

## Del Pezzo surfaces:

$(M^4, J)$  for which  $c_1$  is a Kähler class  $[\omega]$ .  
Shorthand: “ $c_1 > 0$ .”

Blow-up of  $\mathbb{C}P_2$  at  $k$  distinct points,  $0 \leq k \leq 8$ ,  
in general position, or  $\mathbb{C}P_1 \times \mathbb{C}P_1$ .

---

**Theorem.** *Each del Pezzo  $(M^4, J)$  admits a  $J$ -compatible Hermitian, Einstein metric, and this metric is geometrically unique.*

Existence: Page-Derdziński, Siu, Tian-Yau, Tian,  
Odaka-Spotti-Sun,

## Del Pezzo surfaces:

$(M^4, J)$  for which  $c_1$  is a Kähler class  $[\omega]$ .  
Shorthand: “ $c_1 > 0$ .”

Blow-up of  $\mathbb{C}P_2$  at  $k$  distinct points,  $0 \leq k \leq 8$ ,  
in general position, or  $\mathbb{C}P_1 \times \mathbb{C}P_1$ .

---

**Theorem.** *Each del Pezzo  $(M^4, J)$  admits a  $J$ -compatible Hermitian, Einstein metric, and this metric is geometrically unique.*

Existence: Page-Derdziński, Siu, Tian-Yau, Tian,  
Odaka-Spotti-Sun, Chen-L-Weber.

## Del Pezzo surfaces:

$(M^4, J)$  for which  $c_1$  is a Kähler class  $[\omega]$ .  
Shorthand: “ $c_1 > 0$ .”

Blow-up of  $\mathbb{C}P_2$  at  $k$  distinct points,  $0 \leq k \leq 8$ ,  
in general position, or  $\mathbb{C}P_1 \times \mathbb{C}P_1$ .

---

**Theorem.** *Each del Pezzo  $(M^4, J)$  admits a  $J$ -compatible Hermitian, Einstein metric, and this metric is geometrically unique.*

Uniqueness: Bando-Mabuchi '87

## Del Pezzo surfaces:

$(M^4, J)$  for which  $c_1$  is a Kähler class  $[\omega]$ .  
Shorthand: “ $c_1 > 0$ .”

Blow-up of  $\mathbb{C}P_2$  at  $k$  distinct points,  $0 \leq k \leq 8$ ,  
in general position, or  $\mathbb{C}P_1 \times \mathbb{C}P_1$ .

---

**Theorem.** *Each del Pezzo  $(M^4, J)$  admits a  $J$ -compatible Hermitian, Einstein metric, and this metric is geometrically unique.*

Uniqueness: Bando-Mabuchi '87, L '12.

This depends on the following key fact:

**Lemma.** *Let  $(M^4, J)$  be a compact complex surface,*

**Lemma.** *Let  $(M^4, J)$  be a compact complex surface, and suppose that  $g$  is an Einstein metric on  $M$*

**Lemma.** *Let  $(M^4, J)$  be a compact complex surface, and suppose that  $g$  is an Einstein metric on  $M$  which is Hermitian with respect to  $J$ :*

**Lemma.** Let  $(M^4, J)$  be a compact complex surface, and suppose that  $g$  is an Einstein metric on  $M$  which is *Hermitian* with respect to  $J$ :

$$g(J\cdot, J\cdot) = g.$$

**Lemma.** *Let  $(M^4, J)$  be a compact complex surface, and suppose that  $g$  is an Einstein metric on  $M$  which is Hermitian with respect to  $J$ :*

$$g(J\cdot, J\cdot) = g.$$

*Then  $(M^4, g, J)$  is conformally Kähler!*

**Lemma.** Let  $(M^4, J)$  be a compact complex surface, and suppose that  $g$  is an Einstein metric on  $M$  which is Hermitian with respect to  $J$ :

$$g(J\cdot, J\cdot) = g.$$

Then  $(M^4, g, J)$  is conformally Kähler!

---

Strictly four-dimensional phenomenon.

**Lemma.** Let  $(M^4, J)$  be a compact complex surface, and suppose that  $g$  is an Einstein metric on  $M$  which is Hermitian with respect to  $J$ :

$$g(J\cdot, J\cdot) = g.$$

Then  $(M^4, g, J)$  is conformally Kähler!

---

Strictly four-dimensional phenomenon: must have

$$g = fh$$

for some Kähler metric  $h$ , smooth function  $f > 0$ .

**Lemma.** Let  $(M^4, J)$  be a compact complex surface, and suppose that  $g$  is an Einstein metric on  $M$  which is Hermitian with respect to  $J$ :

$$g(J\cdot, J\cdot) = g.$$

Then  $(M^4, g, J)$  is conformally Kähler!

---

**Lemma.** Let  $(M^4, J)$  be a compact complex surface, and suppose that  $g$  is an Einstein metric on  $M$  which is Hermitian with respect to  $J$ :

$$g(J\cdot, J\cdot) = g.$$

Then  $(M^4, g, J)$  is conformally Kähler!

---

Key step: show  $W_+$  has a repeated eigenvalue.

**Lemma.** Let  $(M^4, J)$  be a compact complex surface, and suppose that  $g$  is an Einstein metric on  $M$  which is Hermitian with respect to  $J$ :

$$g(J\cdot, J\cdot) = g.$$

Then  $(M^4, g, J)$  is conformally Kähler!

---

Key step: show  $W_+$  has a repeated eigenvalue.

Riemannian analog of Goldberg-Sachs theorem.

**Lemma.** Let  $(M^4, J)$  be a compact complex surface, and suppose that  $g$  is an Einstein metric on  $M$  which is Hermitian with respect to  $J$ :

$$g(J\cdot, J\cdot) = g.$$

Then  $(M^4, g, J)$  is conformally Kähler!

---

Key step: show  $W_+$  has a repeated eigenvalue.

Riemannian analog of Goldberg-Sachs theorem.

$\nabla \cdot W_+ = 0$ , while  $T^{1,0}M$  isotropic & involutive.

**Lemma.** Let  $(M^4, J)$  be a compact complex surface, and suppose that  $g$  is an Einstein metric on  $M$  which is Hermitian with respect to  $J$ :

$$g(J\cdot, J\cdot) = g.$$

Then  $(M^4, g, J)$  is conformally Kähler!

---

Key step: show  $W_+$  has a repeated eigenvalue.

Riemannian analog of Goldberg-Sachs theorem.

$\nabla \cdot W_+ = 0$ , while  $T^{1,0}M$  isotropic & involutive.

$$\implies W_+ \propto \text{trace-free part of } (\omega \otimes \omega)$$

**Lemma.** Let  $(M^4, J)$  be a compact complex surface, and suppose that  $g$  is an Einstein metric on  $M$  which is Hermitian with respect to  $J$ :

$$g(J\cdot, J\cdot) = g.$$

Then  $(M^4, g, J)$  is conformally Kähler!

---

Key step: show  $W_+$  has a repeated eigenvalue.

Riemannian analog of Goldberg-Sachs theorem.

$\nabla \cdot W_+ = 0$ , while  $T^{1,0}M$  isotropic & involutive.

$$\implies W_+ = u(\omega \otimes \omega)_0$$

**Lemma.** Let  $(M^4, J)$  be a compact complex surface, and suppose that  $g$  is an Einstein metric on  $M$  which is Hermitian with respect to  $J$ :

$$g(J\cdot, J\cdot) = g.$$

Then  $(M^4, g, J)$  is conformally Kähler!

---

Key step: show  $W_+$  has a repeated eigenvalue.

Riemannian analog of Goldberg-Sachs theorem.

$\nabla \cdot W_+ = 0$ , while  $T^{1,0}M$  isotropic & involutive.

Differential Bianchi identity  $\implies 0 = \nabla \cdot u(\omega \otimes \omega)_0$

**Lemma.** Let  $(M^4, J)$  be a compact complex surface, and suppose that  $g$  is an Einstein metric on  $M$  which is Hermitian with respect to  $J$ :

$$g(J\cdot, J\cdot) = g.$$

Then  $(M^4, g, J)$  is conformally Kähler!

---

Key step: show  $W_+$  has a repeated eigenvalue.

Riemannian analog of Goldberg-Sachs theorem.

$\nabla \cdot W_+ = 0$ , while  $T^{1,0}M$  isotropic & involutive.

$$\implies 0 = \hat{\nabla} \cdot (\hat{\omega} \otimes \hat{\omega})_0$$

for  $h = u^{2/3}g$ .

**Lemma.** Let  $(M^4, J)$  be a compact complex surface, and suppose that  $g$  is an Einstein metric on  $M$  which is Hermitian with respect to  $J$ :

$$g(J\cdot, J\cdot) = g.$$

Then  $(M^4, g, J)$  is conformally Kähler!

---

Key step: show  $W_+$  has a repeated eigenvalue.

Riemannian analog of Goldberg-Sachs theorem.

$\nabla \cdot W_+ = 0$ , while  $T^{1,0}M$  isotropic & involutive.

$$0 = \hat{\nabla} \hat{\omega}$$

for  $h = u^{2/3}g$ .

**Lemma.** Let  $(M^4, J)$  be a compact complex surface, and suppose that  $g$  is an Einstein metric on  $M$  which is Hermitian with respect to  $J$ :

$$g(J\cdot, J\cdot) = g.$$

Then  $(M^4, g, J)$  is conformally Kähler!

---

Key step: show  $W_+$  has a repeated eigenvalue.

Riemannian analog of Goldberg-Sachs theorem.

$\nabla \cdot W_+ = 0$ , while  $T^{1,0}M$  isotropic & involutive.

$$0 = \hat{\nabla} \hat{\omega}$$

so  $h = u^{2/3}g$  is Kähler.

**Lemma.** Let  $(M^4, J)$  be a compact complex surface, and suppose that  $g$  is an Einstein metric on  $M$  which is Hermitian with respect to  $J$ :

$$g(J\cdot, J\cdot) = g.$$

Then  $(M^4, g, J)$  is conformally Kähler!

---

Key step: show  $W_+$  has a repeated eigenvalue.

Riemannian analog of Goldberg-Sachs theorem.

$\nabla \cdot W_+ = 0$ , while  $T^{1,0}M$  isotropic & involutive.

$$0 = \hat{\nabla} \hat{\omega}$$

so  $h = u^{2/3}g$  is Kähler. (Derdziński, L)

**Lemma.** Let  $(M^4, J)$  be a compact complex surface, and suppose that  $g$  is an Einstein metric on  $M$  which is Hermitian with respect to  $J$ :

$$g(J\cdot, J\cdot) = g.$$

Then  $(M^4, g, J)$  is conformally Kähler!

---

**Lemma.** *Let  $(M^4, J)$  be a compact complex surface, and suppose that  $g$  is an Einstein metric on  $M$  which is Hermitian with respect to  $J$ :*

$$g(J\cdot, J\cdot) = g.$$

*Then  $(M^4, g, J)$  is conformally Kähler!*

---

Strictly four-dimensional phenomenon.

**Lemma.** Let  $(M^4, J)$  be a compact complex surface, and suppose that  $g$  is an Einstein metric on  $M$  which is Hermitian with respect to  $J$ :

$$g(J\cdot, J\cdot) = g.$$

Then  $(M^4, g, J)$  is conformally Kähler!

---

Strictly four-dimensional phenomenon.

Wildly false in higher dimensions!

**Lemma.** *Let  $(M^4, J)$  be a compact complex surface, and suppose that  $g$  is an Einstein metric on  $M$  which is Hermitian with respect to  $J$ :*

$$g(J\cdot, J\cdot) = g.$$

*Then  $(M^4, g, J)$  is conformally Kähler!*

---

Strictly four-dimensional phenomenon.

Wildly false in higher dimensions!

Calabi-Eckmann complex structure  $J$  on  $S^3 \times S^3$ .

**Lemma.** *Let  $(M^4, J)$  be a compact complex surface, and suppose that  $g$  is an Einstein metric on  $M$  which is Hermitian with respect to  $J$ :*

$$g(J\cdot, J\cdot) = g.$$

*Then  $(M^4, g, J)$  is conformally Kähler!*

---

Strictly four-dimensional phenomenon.

Wildly false in higher dimensions!

Calabi-Eckmann complex structure  $J$  on  $S^3 \times S^3$ .

Product metric is Einstein and Hermitian.

**Lemma.** Let  $(M^4, J)$  be a compact complex surface, and suppose that  $g$  is an Einstein metric on  $M$  which is Hermitian with respect to  $J$ :

$$g(J\cdot, J\cdot) = g.$$

Then  $(M^4, g, J)$  is conformally Kähler!

---

Strictly four-dimensional phenomenon.

Wildly false in higher dimensions!

Calabi-Eckmann complex structure  $J$  on  $S^3 \times S^3$ .

Product metric is Einstein and Hermitian.

But  $S^3 \times S^3$  has no Kähler metric because  $H^2 = 0$ .

**Lemma.** Let  $(M^4, J)$  be a compact complex surface, and suppose that  $g$  is an Einstein metric on  $M$  which is Hermitian with respect to  $J$ :

$$g(J\cdot, J\cdot) = g.$$

Then  $(M^4, g, J)$  is conformally Kähler!

---

Strictly four-dimensional phenomenon.

Wildly false in higher dimensions!

Calabi-Eckmann complex structure  $J$  on  $S^3 \times S^3$ .

Product metric is Einstein and Hermitian.

But  $S^3 \times S^3$  has no Kähler metric because  $H^2 = 0$ .

Similarly for  $S^{2n+1} \times S^{2m+1}$ .

**Lemma.** Let  $(M^4, J)$  be a compact complex surface, and suppose that  $g$  is an Einstein metric on  $M$  which is Hermitian with respect to  $J$ :

$$g(J\cdot, J\cdot) = g.$$

Then  $(M^4, g, J)$  is conformally Kähler!

---

## The Bach Tensor

Conformally invariant Riemannian functional:

$$\mathcal{W}(g) = \int_M |W|_g^2 d\mu_g.$$

## The Bach Tensor

Conformally invariant Riemannian functional:

$$\mathcal{W}(g) = \int_M |W|_g^2 d\mu_g.$$

Conformally invariant means unchanged by

$$g \rightsquigarrow u^2 g$$

for any smooth function  $u : M \rightarrow \mathbb{R}^+$ .

## The Bach Tensor

Conformally invariant Riemannian functional:

$$\mathcal{W}(g) = \int_M |W|_g^2 d\mu_g.$$

## The Bach Tensor

Conformally invariant Riemannian functional:

$$\mathcal{W}(g) = \int_M |W|_g^2 d\mu_g.$$

For any 1-parameter family of metrics

$$g_t := g + t\dot{g} + O(t^2)$$

## The Bach Tensor

Conformally invariant Riemannian functional:

$$\mathcal{W}(g) = \int_M |W|_g^2 d\mu_g.$$

For any 1-parameter family of metrics

$$g_t := g + t\dot{g} + O(t^2)$$

First variation

$$\left. \frac{d}{dt} \mathcal{W}(g_t) \right|_{t=0} = - \int \dot{g}^{ab} B_{ab} d\mu_g$$

## The Bach Tensor

Conformally invariant Riemannian functional:

$$\mathcal{W}(g) = \int_M |W|_g^2 d\mu_g.$$

For any 1-parameter family of metrics

$$g_t := g + t\dot{g} + O(t^2)$$

First variation

$$\left. \frac{d}{dt} \mathcal{W}(g_t) \right|_{t=0} = - \int \dot{g}^{ab} B_{ab} d\mu_g$$

where

$$B_{ab} := (\nabla^c \nabla^d + \frac{1}{2} r^{cd}) W_{acbd}.$$

is the Bach tensor of  $g$ .

## The Bach Tensor

Conformally invariant Riemannian functional:

$$\mathcal{W}(g) = \int_M |W|_g^2 d\mu_g.$$

For any 1-parameter family of metrics

$$g_t := g + t\dot{g} + O(t^2)$$

First variation

$$\left. \frac{d}{dt} \mathcal{W}(g_t) \right|_{t=0} = - \int \dot{g}^{ab} B_{ab} d\mu_g$$

where

$$B_{ab} := (\nabla^c \nabla^d + \frac{1}{2} r^{cd}) W_{acbd}.$$

is the **Bach tensor** of  $g$ . Symmetric, trace-free.

## The Bach Tensor

Conformally invariant Riemannian functional:

$$\mathcal{W}(g) = \int_M |W|_g^2 d\mu_g.$$

For any 1-parameter family of metrics

$$g_t := g + t\dot{g} + O(t^2)$$

First variation

$$\left. \frac{d}{dt} \mathcal{W}(g_t) \right|_{t=0} = - \int \dot{g}^{ab} B_{ab} d\mu_g$$

where

$$B_{ab} := (\nabla^c \nabla^d + \frac{1}{2} r^{cd}) W_{acbd}.$$

is the **Bach tensor** of  $g$ . Symmetric, trace-free.

$$\nabla^a B_{ab} = 0$$

## 4-dimensional Gauss-Bonnet formula

$$\chi(M) = \frac{1}{8\pi^2} \int_M \left( \frac{s^2}{24} + |W|^2 - \frac{|\dot{r}|^2}{2} \right) d\mu$$

## 4-dimensional Gauss-Bonnet formula

$$\chi(M) = \frac{1}{8\pi^2} \int_M \left( \frac{s^2}{24} + |W|^2 - \frac{|\mathring{r}|^2}{2} \right) d\mu$$

So

$$\mathcal{W}(g) = 8\pi^2 \chi(M) - \int_M \left( \frac{s^2}{24} - \frac{|\mathring{r}|^2}{2} \right) d\mu$$

## 4-dimensional Gauss-Bonnet formula

$$\chi(M) = \frac{1}{8\pi^2} \int_M \left( \frac{s^2}{24} + |W|^2 - \frac{|\mathring{r}|^2}{2} \right) d\mu$$

So

$$\mathcal{W}(g) = 8\pi^2 \chi(M) - \int_M \left( \frac{s^2}{24} - \frac{|\mathring{r}|^2}{2} \right) d\mu$$

$\implies$  Einstein metrics are critical points of  $\mathcal{W}$ ,

## 4-dimensional Gauss-Bonnet formula

$$\chi(M) = \frac{1}{8\pi^2} \int_M \left( \frac{s^2}{24} + |W|^2 - \frac{|\mathring{r}|^2}{2} \right) d\mu$$

So

$$\mathcal{W}(g) = 8\pi^2 \chi(M) - \int_M \left( \frac{s^2}{24} - \frac{|\mathring{r}|^2}{2} \right) d\mu$$

$\implies$  Einstein metrics are critical points of  $\mathcal{W}$ ,

since they are critical points of  $\int s^2 d\mu$  and  $\int |\mathring{r}|^2 d\mu$ .

## 4-dimensional Gauss-Bonnet formula

$$\chi(M) = \frac{1}{8\pi^2} \int_M \left( \frac{s^2}{24} + |W|^2 - \frac{|\mathring{r}|^2}{2} \right) d\mu$$

So

$$\mathcal{W}(g) = 8\pi^2 \chi(M) - \int_M \left( \frac{s^2}{24} - \frac{|\mathring{r}|^2}{2} \right) d\mu$$

$\implies$  Einstein metrics are critical points of  $\mathcal{W}$ .

## 4-dimensional Gauss-Bonnet formula

$$\chi(M) = \frac{1}{8\pi^2} \int_M \left( \frac{s^2}{24} + |W|^2 - \frac{|\mathring{r}|^2}{2} \right) d\mu$$

So

$$\mathcal{W}(g) = 8\pi^2 \chi(M) - \int_M \left( \frac{s^2}{24} - \frac{|\mathring{r}|^2}{2} \right) d\mu$$

$\implies$  Einstein metrics are critical points of  $\mathcal{W}$ .

$\implies$  conformally Einstein metrics are critical, too.

4-dimensional signature formula

$$\tau(M) = \frac{1}{12\pi^2} \int_M (|W_+|^2 - |W_-|^2) d\mu$$

## 4-dimensional signature formula

$$\tau(M) = \frac{1}{12\pi^2} \int_M (|W_+|^2 - |W_-|^2) d\mu$$

So

$$\mathcal{W}(g) = 2 \int_M |W_+|^2 d\mu_g - 12\pi^2 \tau(M)$$

4-dimensional signature formula

$$\tau(M) = \frac{1}{12\pi^2} \int_M (|W_+|^2 - |W_-|^2) d\mu$$

So

$$\mathcal{W}(g) = 2 \int_M |W_+|^2 d\mu_g - 12\pi^2 \tau(M)$$

Hence

$$B_{ab} := 2(\nabla^c \nabla^d + \frac{1}{2} \mathring{r}^{cd})(W_+)_{acbd} .$$

4-dimensional signature formula

$$\tau(M) = \frac{1}{12\pi^2} \int_M (|W_+|^2 - |W_-|^2) d\mu$$

So

$$\mathcal{W}(g) = 2 \int_M |W_+|^2 d\mu_g - 12\pi^2 \tau(M)$$

Hence

$$B_{ab} := 2(\nabla^c \nabla^d + \frac{1}{2} \mathring{r}^{cd})(W_+)_{acbd}.$$

So what does the identity

$$B_{ab} = 0$$

say about conformally Kähler, Einstein metrics?

Riemann curvature of  $g$

$$\mathcal{R} : \Lambda^2 \rightarrow \Lambda^2$$

splits into 4 irreducible pieces:

	$\Lambda^{+*}$	$\Lambda^{-*}$
$\Lambda^+$	$W_+ + \frac{s}{12}$	$\overset{\circ}{r}$
$\Lambda^-$	$\overset{\circ}{r}$	$W_- + \frac{s}{12}$

where

$s$  = scalar curvature

$\overset{\circ}{r}$  = trace-free Ricci curvature

$W_+$  = self-dual Weyl curvature (*conformally invariant*)

$W_-$  = anti-self-dual Weyl curvature //

Kähler case:

$$\Lambda^{1,1} = \mathbb{R}\omega \oplus \Lambda^-$$

Kähler case:

$$\Lambda^{1,1} = \mathbb{R}\omega \oplus \Lambda^-$$

$$\Lambda^+ = \mathbb{R}\omega \oplus \Re(\Lambda^{2,0})$$

Kähler case:

$$\Lambda^{1,1} = \mathbb{R}\omega \oplus \Lambda^-$$

$$\Lambda^+ = \mathbb{R}\omega \oplus \Re(\Lambda^{2,0})$$

$$\nabla J = 0 \implies \mathcal{R} \in \text{End}(\Lambda^{1,1})$$

Kähler case:

$$\Lambda^{1,1} = \mathbb{R}\omega \oplus \Lambda^-$$

$$\Lambda^+ = \mathbb{R}\omega \oplus \Re(\Lambda^{2,0})$$

$$\nabla J = 0 \implies \mathcal{R} \in \text{End}(\Lambda^{1,1})$$

	$\Lambda^{+*}$	$\Lambda^{-*}$
$\Lambda^+$	$W_+ + \frac{s}{12}$	$\mathring{r}$
$\Lambda^-$	$\mathring{r}$	$W_- + \frac{s}{12}$

Kähler case:

$$\Lambda^{1,1} = \mathbb{R}\omega \oplus \Lambda^-$$

$$\Lambda^+ = \mathbb{R}\omega \oplus \Re(\Lambda^{2,0})$$

$$\nabla J = 0 \implies \mathcal{R} \in \text{End}(\Lambda^{1,1})$$

	$\Lambda^{+*}$	$\Lambda^{-*}$
$\Lambda^+$	$W_+ + \frac{s}{12}$	$\mathring{r}$
$\Lambda^-$	$\mathring{r}$	$W_- + \frac{s}{12}$

The bottom-right cell of the table is shaded with a dotted pattern.

Kähler case:

$$\Lambda^{1,1} = \mathbb{R}\omega \oplus \Lambda^-$$

$$\Lambda^+ = \mathbb{R}\omega \oplus \Re(\Lambda^{2,0})$$

$$\nabla J = 0 \implies \mathcal{R} \in \text{End}(\Lambda^{1,1}) \implies$$

$$W_+ + \frac{s}{12} = \begin{pmatrix} 0 & & \\ & 0 & \\ & & * \end{pmatrix}$$

Kähler case:

$$\Lambda^{1,1} = \mathbb{R}\omega \oplus \Lambda^-$$

$$\Lambda^+ = \mathbb{R}\omega \oplus \Re(\Lambda^{2,0})$$

$$\nabla J = 0 \implies \mathcal{R} \in \text{End}(\Lambda^{1,1}) \implies$$

$$W_+ + \frac{s}{12} = \begin{pmatrix} 0 & & \\ & 0 & \\ & & \frac{s}{4} \end{pmatrix}$$

Kähler case:

$$\Lambda^{1,1} = \mathbb{R}\omega \oplus \Lambda^-$$

$$\Lambda^+ = \mathbb{R}\omega \oplus \Re(\Lambda^{2,0})$$

$$\nabla J = 0 \implies \mathcal{R} \in \text{End}(\Lambda^{1,1}) \implies$$

$$W_+ = \begin{pmatrix} -\frac{s}{12} & & \\ & -\frac{s}{12} & \\ & & \frac{s}{6} \end{pmatrix}$$

Kähler case:

$$\Lambda^{1,1} = \mathbb{R}\omega \oplus \Lambda^-$$

$$\Lambda^+ = \mathbb{R}\omega \oplus \Re(\Lambda^{2,0})$$

$$\nabla J = 0 \implies \mathcal{R} \in \text{End}(\Lambda^{1,1}) \implies$$

$$|W_+|^2 = \frac{s^2}{24}$$

Restriction of  $\mathcal{W}$  to Kähler metrics?

## Restriction of $\mathcal{W}$ to Kähler metrics?

On Kähler metrics,

$$\int |W_+|^2 d\mu = \int \frac{s^2}{24} d\mu$$

## Restriction of $\mathcal{W}$ to Kähler metrics?

On Kähler metrics,

$$\int |W_+|^2 d\mu = \int \frac{s^2}{24} d\mu$$

so any critical point of restriction must be **extremal** in sense of Calabi.

Calabi:

Calabi:

Extremal Kähler metrics = critical points of

$$h \mapsto \int_M s^2 d\mu_h$$

Calabi:

Extremal Kähler metrics = critical points of

$$h \mapsto \int_M s^2 d\mu_h$$

where  $h = h_\omega$  for  $J$  and  $[\omega] \in H^2(M, \mathbb{R})$  fixed.

Calabi:

Extremal Kähler metrics = critical points of

$$h \mapsto \int_M s^2 d\mu_h$$

where  $h = h_\omega$  for  $J$  and  $[\omega] \in H^2(M, \mathbb{R})$  fixed.

Euler-Lagrange equations

Calabi:

Extremal Kähler metrics = critical points of

$$h \mapsto \int_M s^2 d\mu_h$$

where  $h = h_\omega$  for  $J$  and  $[\omega] \in H^2(M, \mathbb{R})$  fixed.

Euler-Lagrange equations  $\iff$

$\nabla^{1,0} s$  is a holomorphic vector field.

Calabi:

Extremal Kähler metrics = critical points of

$$h \mapsto \int_M s^2 d\mu_h$$

where  $h = h_\omega$  for  $J$  and  $[\omega] \in H^2(M, \mathbb{R})$  fixed.

Euler-Lagrange equations  $\iff$

$J\nabla s$  is a Killing field.

Calabi:

Extremal Kähler metrics = critical points of

$$h \mapsto \int_M s^2 d\mu_h$$

where  $h = h_\omega$  for  $J$  and  $[\omega] \in H^2(M, \mathbb{R})$  fixed.

Euler-Lagrange equations  $\iff$

$J\nabla s$  is a Killing field.

X.X. Chen: always minimizers.

Calabi:

Extremal Kähler metrics = critical points of

$$h \mapsto \int_M s^2 d\mu_h$$

where  $h = h_\omega$  for  $J$  and  $[\omega] \in H^2(M, \mathbb{R})$  fixed.

Euler-Lagrange equations  $\iff$

$J\nabla s$  is a Killing field.

Donaldson/Mabuchi/Chen-Tian:  
unique modulo bihomorphisms.

## Restriction of $\mathcal{W}$ to Kähler metrics?

On Kähler metrics,

$$\int |W_+|^2 d\mu = \int \frac{s^2}{24} d\mu$$

so any critical point of restriction must be **extremal** in sense of Calabi.

## Restriction of $\mathcal{W}$ to Kähler metrics?

On Kähler metrics,

$$\int |W_+|^2 d\mu = \int \frac{s^2}{24} d\mu$$

so any critical point of restriction must be **extremal** in sense of Calabi.

Now for an extremal Kähler metric

$$B = \frac{1}{12} \left[ s\dot{r} + 2\text{Hess}_0(s) \right]$$

## Restriction of $\mathcal{W}$ to Kähler metrics?

On Kähler metrics,

$$\int |W_+|^2 d\mu = \int \frac{s^2}{24} d\mu$$

so any critical point of restriction must be **extremal** in sense of Calabi.

Now for an extremal Kähler metric

$$B = \frac{1}{12} \left[ s\dot{r} + 2\text{Hess}_0(s) \right]$$

because  $W_+ = \frac{1}{4}s(\omega \otimes \omega)_0$  in Kähler case

## Restriction of $\mathcal{W}$ to Kähler metrics?

On Kähler metrics,

$$\int |W_+|^2 d\mu = \int \frac{s^2}{24} d\mu$$

so any critical point of restriction must be **extremal** in sense of Calabi.

Now for an extremal Kähler metric

$$B = \frac{1}{12} \left[ s\dot{r} + 2\text{Hess}_0(s) \right]$$

where  $\text{Hess}_0(s)$  is the trace-free piece of  $\nabla\nabla s$

## Restriction of $\mathcal{W}$ to Kähler metrics?

On Kähler metrics,

$$\int |W_+|^2 d\mu = \int \frac{s^2}{24} d\mu$$

so any critical point of restriction must be **extremal** in sense of Calabi.

Now for an extremal Kähler metric

$$B = \frac{1}{12} \left[ s\dot{r} + 2\text{Hess}_0(s) \right]$$

## Restriction of $\mathcal{W}$ to Kähler metrics?

On Kähler metrics,

$$\int |W_+|^2 d\mu = \int \frac{s^2}{24} d\mu$$

so any critical point of restriction must be **extremal** in sense of Calabi.

Now for an extremal Kähler metric

$$B = \frac{1}{12} \left[ s\dot{r} + 2\text{Hess}_0(s) \right]$$

and corresponds to **harmonic** primitive  $(1, 1)$ -form

$$\psi := B(J\cdot, \cdot) = \frac{1}{12} \left[ s\rho + 2i\partial\bar{\partial}s \right]_0$$

Restriction of  $\mathcal{W}$  to Kähler metrics.

Restriction of  $\mathcal{W}$  to Kähler metrics.

Hence if  $h$  is extremal Kähler metric,

$$h_t = h + tB$$

is a family of Kähler metrics,

## Restriction of $\mathcal{W}$ to Kähler metrics.

Hence if  $h$  is extremal Kähler metric,

$$h_t = h + tB$$

is a family of Kähler metrics, for  $t \in (-\varepsilon, \varepsilon)$ ,

Restriction of  $\mathcal{W}$  to Kähler metrics.

Hence if  $h$  is extremal Kähler metric,

$$h_t = h + tB$$

is a family of Kähler metrics,

## Restriction of $\mathcal{W}$ to Kähler metrics.

Hence if  $h$  is extremal Kähler metric,

$$h_t = h + tB$$

is a family of Kähler metrics, corresponding to

$$\omega_t = \omega + t\psi$$

## Restriction of $\mathcal{W}$ to Kähler metrics.

Hence if  $h$  is extremal Kähler metric,

$$h_t = h + tB$$

is a family of Kähler metrics, corresponding to

$$\omega_t = \omega + t\psi$$

and first variation is

$$\begin{aligned} \left. \frac{d}{dt} \mathcal{W}(h_t) \right|_{t=0} &= \int \dot{g}^{ab} B_{ab} d\mu_h \\ &= - \int |B|^2 d\mu_h \end{aligned}$$

## Restriction of $\mathcal{W}$ to Kähler metrics.

Hence if  $h$  is extremal Kähler metric,

$$h_t = h + tB$$

is a family of Kähler metrics, corresponding to

$$\omega_t = \omega + t\psi$$

and first variation is

$$\begin{aligned} \left. \frac{d}{dt} \mathcal{W}(h_t) \right|_{t=0} &= \int \dot{g}^{ab} B_{ab} d\mu_h \\ &= - \int |B|^2 d\mu_h. \end{aligned}$$

So the critical points of restriction of  $\mathcal{W}$  to  $\{\text{Kähler metrics}\}$  must also have  $B = 0$ !

Thus any critical point of restriction has

$$0 = 12B = s\dot{r} + 2\text{Hess}_0(s)$$

Thus any critical point of restriction has

$$0 = 12B = s\dot{r} + 2\text{Hess}_0(s)$$

$\implies$  the conformal rescaling  $g = s^{-2}h$  is  
Einstein

Thus any critical point of restriction has

$$0 = 12B = s\mathring{r} + 2\text{Hess}_0(s)$$

$\implies$  the conformal rescaling  $g = s^{-2}h$  is Einstein courtesy of transformation rule

$$\mathring{r}(u^2h) = \mathring{r}(h) + (n - 2)u\text{Hess}_0(u^{-1}) .$$

Thus any critical point of restriction has

$$0 = 12B = s\mathring{r} + 2\text{Hess}_0(s)$$

$\implies$  the conformal rescaling  $g = s^{-2}h$  is Einstein courtesy of transformation rule

$$\mathring{r}(u^2h) = \mathring{r}(h) + 2u \text{Hess}_0(u^{-1}) .$$

Thus any critical point of restriction has

$$0 = 12B = s\mathring{r} + 2\text{Hess}_0(s)$$

$\implies$  the conformal rescaling  $g = s^{-2}h$  is Einstein courtesy of transformation rule

$$\mathring{r}(u^2h) = \mathring{r}(h) + 2u \text{Hess}_0(u^{-1}) .$$

$$\mathring{r}(s^{-2}h) = \mathring{r}(h) + 2s^{-1}\text{Hess}_0(s)$$

Thus any critical point of restriction has

$$0 = 12B = s\mathring{r} + 2\text{Hess}_0(s)$$

$\implies$  the conformal rescaling  $g = s^{-2}h$  is Einstein courtesy of transformation rule

$$\mathring{r}(u^2h) = \mathring{r}(h) + 2u \text{Hess}_0(u^{-1}) .$$

$$\mathring{r}(s^{-2}h) = \mathring{r}(h) + 2s^{-1}\text{Hess}_0(s) = 12s^{-1}B = 0.$$

Thus any critical point of restriction has

$$0 = 12B = s\dot{r} + 2\text{Hess}_0(s)$$

$\implies$  the conformal rescaling  $g = s^{-2}h$  is Einstein courtesy of transformation rule

$$\dot{r}(u^2h) = \dot{r}(h) + 2u \text{Hess}_0(u^{-1}) .$$

$$\dot{r}(s^{-2}h) = \dot{r}(h) + 2s^{-1}\text{Hess}_0(s) = 12s^{-1}B = 0.$$

This conformal rescaling trick due to [Derdziński](#).

Thus any critical point of restriction has

$$0 = 12B = s\dot{r} + 2\text{Hess}_0(s)$$

$\implies$  the conformal rescaling  $g = s^{-2}h$  is Einstein courtesy of transformation rule

$$\dot{r}(u^2h) = \dot{r}(h) + 2u \text{Hess}_0(u^{-1}) .$$

$$\dot{r}(s^{-2}h) = \dot{r}(h) + 2s^{-1}\text{Hess}_0(s) = 12s^{-1}B = 0.$$

This conformal rescaling trick due to [Derdziński](#).

**WARNING.**  $h$  undefined where  $s = 0$ !

Thus any critical point of restriction has

$$0 = 12B = s\mathring{r} + 2\text{Hess}_0(s)$$

$\implies$  the conformal rescaling  $g = s^{-2}h$  is Einstein courtesy of transformation rule

$$\mathring{r}(u^2h) = \mathring{r}(h) + 2u \text{Hess}_0(u^{-1}) .$$

$$\mathring{r}(s^{-2}h) = \mathring{r}(h) + 2s^{-1}\text{Hess}_0(s) = 12s^{-1}B = 0.$$

This conformal rescaling trick due to [Derdziński](#).

**WARNING.**  $h$  undefined where  $s = 0$ !

For global Einstein metric, need to show  $s > 0$ .

**Lemma.** *Suppose compact complex surface  $(M^4, J)$  admits a Hermitian  $g$  which is Einstein, but not Kähler. Then  $(M^4, J)$  is a Del Pezzo surface.*

**Lemma.** *Suppose compact complex surface  $(M^4, J)$  admits a Hermitian  $g$  which is Einstein, but not Kähler. Then  $(M^4, J)$  is a Del Pezzo surface.*

Metric is conformal to Kähler metric  $h$  with

**Lemma.** *Suppose compact complex surface  $(M^4, J)$  admits a Hermitian  $g$  which is Einstein, but not Kähler. Then  $(M^4, J)$  is a Del Pezzo surface.*

Metric is conformal to Kähler metric  $h$  with

$$\rho + 2i\partial\bar{\partial}\log s > 0$$

**Lemma.** *Suppose compact complex surface  $(M^4, J)$  admits a Hermitian  $g$  which is Einstein, but not Kähler. Then  $(M^4, J)$  is a Del Pezzo surface.*

Metric is conformal to Kähler metric  $h$  with

$$\rho + 2i\partial\bar{\partial}\log s > 0$$

so  $c_1 > 0$ .

**Lemma.** *Suppose compact complex surface  $(M^4, J)$  admits a Hermitian  $g$  which is Einstein, but not Kähler. Then  $(M^4, J)$  is a Del Pezzo surface.*

**Lemma.** *Suppose compact complex surface  $(M^4, J)$  admits a Hermitian  $g$  which is Einstein, but not Kähler. Then  $(M^4, J)$  is a Del Pezzo surface.*

**Lemma.** *If  $(M^4, J)$  is a Del Pezzo surface, any extremal Kähler metric  $h$  on  $M$  has scalar curvature  $s > 0$ .*

**Lemma.** *Suppose compact complex surface  $(M^4, J)$  admits a Hermitian  $g$  which is **Einstein**, but not Kähler. Then  $(M^4, J)$  is a **Del Pezzo surface**.*

**Lemma.** *If  $(M^4, J)$  is a **Del Pezzo surface**, any extremal Kähler metric  $h$  on  $M$  has scalar curvature  $s > 0$ .*

This comes down to a computation!

**Lemma.** *Suppose compact complex surface  $(M^4, J)$  admits a Hermitian  $g$  which is Einstein, but not Kähler. Then  $(M^4, J)$  is a Del Pezzo surface.*

**Lemma.** *If  $(M^4, J)$  is a Del Pezzo surface, any extremal Kähler metric  $h$  on  $M$  has scalar curvature  $s > 0$ .*

This comes down to a computation!

But it then immediately implies...

**Lemma.** *Suppose compact complex surface  $(M^4, J)$  admits a Hermitian  $g$  which is Einstein, but not Kähler. Then  $(M^4, J)$  is a Del Pezzo surface.*

**Lemma.** *If  $(M^4, J)$  is a Del Pezzo surface, any extremal Kähler metric  $h$  on  $M$  has scalar curvature  $s > 0$ .*

**Lemma.** *Suppose that  $h$  is a Bach-flat Kähler metric on a Del Pezzo surface  $(M^4, J)$ . Then the Hermitian metric  $g = s^{-2}h$  is Einstein, with positive Einstein constant.*

**Lemma.** Suppose compact complex surface  $(M^4, J)$  admits a Hermitian  $g$  which is *Einstein*, but not Kähler. Then  $(M^4, J)$  is a *Del Pezzo surface*.

**Lemma.** If  $(M^4, J)$  is a *Del Pezzo surface*, any extremal Kähler metric  $h$  on  $M$  has scalar curvature  $s > 0$ .

**Lemma.** Suppose that  $h$  is a Bach-flat Kähler metric on a *Del Pezzo surface*  $(M^4, J)$ . Then the Hermitian metric  $g = s^{-2}h$  is *Einstein*, with positive Einstein constant.

**Lemma.** Conversely, any Hermitian, *Einstein* metric on a *Del Pezzo surface* arises in this way.

**Theorem.** *Let  $(M^4, J)$  be a Del Pezzo surface. Then, up to automorphisms and rescaling, there is a **unique** Bach-flat Kähler metric  $h$  on  $M$ . This metric is characterized by the fact that it minimizes the Calabi functional*

$$C = \int_M s^2 d\mu$$

*among all Kähler metrics on  $(M^4, J)$ .*

**Theorem.** *Let  $(M^4, J)$  be a Del Pezzo surface. Then, up to automorphisms and rescaling, there is a **unique** Bach-flat Kähler metric  $h$  on  $M$ . This metric is characterized by the fact that it minimizes the Calabi functional*

$$C = \int_M s^2 d\mu$$

*among all Kähler metrics on  $(M^4, J)$ .*

Hermitian, Einstein metric then given by

$$g = s^{-2}h$$

and uniqueness **Theorem** follows.

**Theorem.** Let  $(M^4, J)$  be a *Del Pezzo surface*. Then, up to automorphisms and rescaling, there is a *unique Bach-flat Kähler metric  $h$*  on  $M$ . This metric is characterized by the fact that it *minimizes the Calabi functional*

$$C = \int_M s^2 d\mu$$

among all Kähler metrics on  $(M^4, J)$ .

Only three cases are “non-trivial:”

$$\mathbb{C}P_2 \# k \overline{\mathbb{C}P_2}, \quad k = 1, 2, 3.$$

**Theorem.** *Let  $(M^4, J)$  be a Del Pezzo surface. Then, up to automorphisms and rescaling, there is a **unique** Bach-flat Kähler metric  $h$  on  $M$ . This metric is characterized by the fact that it minimizes the Calabi functional*

$$C = \int_M s^2 d\mu$$

*among all Kähler metrics on  $(M^4, J)$ .*

Only three cases are “non-trivial:”

$$\mathbb{C}P_2 \# k \overline{\mathbb{C}P_2}, \quad k = 1, 2, 3.$$

In all other cases, any extremal Kähler metric must have  $s \equiv \text{const}$ , so that any Hermitian, **Einstein** metric must be **Kähler-Einstein**.

**Theorem.** *Let  $(M^4, J)$  be a Del Pezzo surface. Then, up to automorphisms and rescaling, there is a **unique** Bach-flat Kähler metric  $h$  on  $M$ . This metric is characterized by the fact that it minimizes the Calabi functional*

$$C = \int_M s^2 d\mu$$

*among all Kähler metrics on  $(M^4, J)$ .*

Only three cases are “non-trivial:”

$$\mathbb{C}P_2 \# k \overline{\mathbb{C}P_2}, \quad k = 1, 2, 3.$$

The Kähler-Einstein case is of course quite non-trivial, for complementary reasons. For a watertight treatment, see [Odaka-Spotti-Sun 2016](#).

# Action Function on Kähler Cone

## Action Function on Kähler Cone

For any extremal Kähler  $(M^4, h, J)$ ,

## Action Function on Kähler Cone

For any extremal Kähler  $(M^4, h, J)$ ,

$$\frac{1}{32\pi^2} \int s^2 d\mu_h = \frac{(c_1 \cdot [\omega])^2}{[\omega]^2} + \frac{1}{32\pi^2} \|\mathcal{F}_{[\omega]}\|^2$$

## Action Function on Kähler Cone

For any extremal Kähler  $(M^4, h, J)$ ,

$$\frac{1}{32\pi^2} \int s^2 d\mu_h = \frac{(c_1 \cdot [\omega])^2}{[\omega]^2} + \frac{1}{32\pi^2} \|\mathcal{F}_{[\omega]}\|^2$$

where  $\mathcal{F}$  is Futaki invariant.

## Action Function on Kähler Cone

For any extremal Kähler  $(M^4, h, J)$ ,

$$\begin{aligned} \frac{1}{32\pi^2} \int s^2 d\mu_h &= \frac{(c_1 \cdot [\omega])^2}{[\omega]^2} + \frac{1}{32\pi^2} \|\mathcal{F}_{[\omega]}\|^2 \\ &=: \mathcal{A}([\omega]) \end{aligned}$$

where  $\mathcal{F}$  is Futaki invariant.

## Action Function on Kähler Cone

For any extremal Kähler  $(M^4, h, J)$ ,

$$\begin{aligned} \frac{1}{32\pi^2} \int s^2 d\mu_h &= \frac{(c_1 \cdot [\omega])^2}{[\omega]^2} + \frac{1}{32\pi^2} \|\mathcal{F}_{[\omega]}\|^2 \\ &=: \mathcal{A}([\omega]) \end{aligned}$$

where  $\mathcal{F}$  is Futaki invariant.

$\mathcal{A}$  is function on Kähler cone  $\mathcal{K} \subset H^2(M, \mathbb{R})$ .

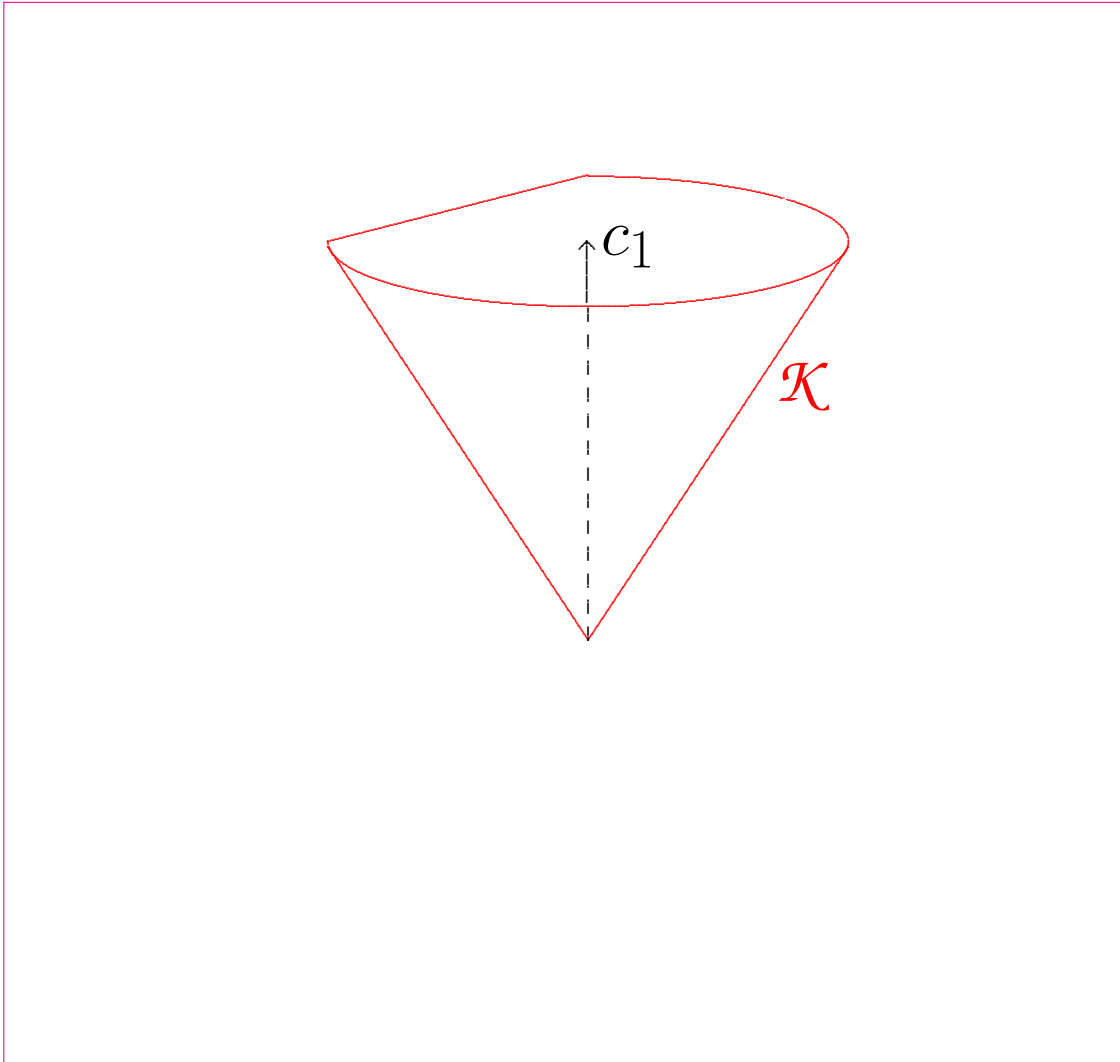

$$\mathcal{K} \subset H^{1,1}(M, \mathbb{R}) = H^2(M, \mathbb{R})$$

( $M$  Del Pezzo)

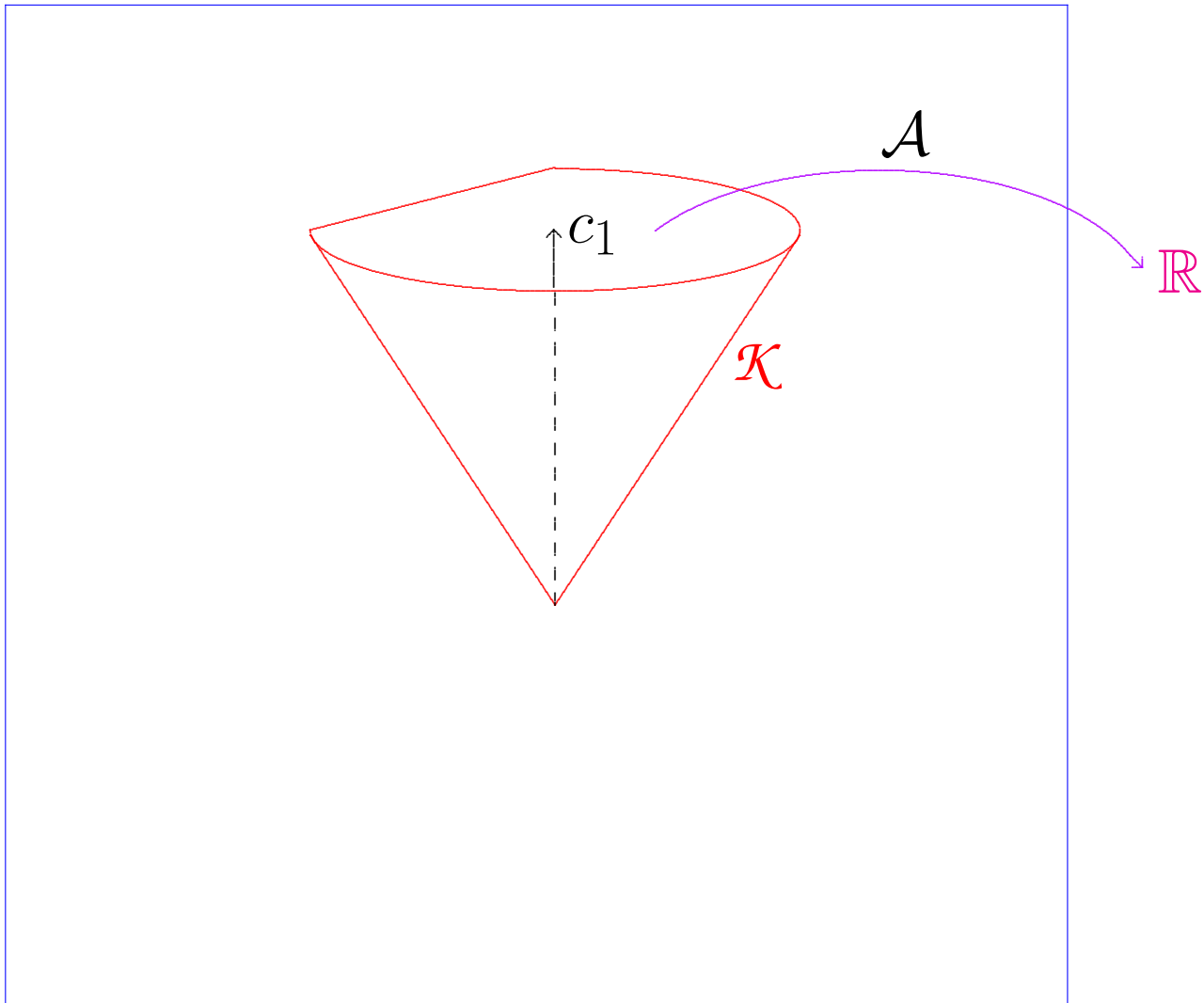

$$\mathcal{K} \subset H^{1,1}(M, \mathbb{R}) = H^2(M, \mathbb{R})$$

( $M$  Del Pezzo)

## Action Function on Kähler Cone

For any extremal Kähler  $(M^4, h, J)$ ,

$$\begin{aligned} \frac{1}{32\pi^2} \int s^2 d\mu_h &= \frac{(c_1 \cdot [\omega])^2}{[\omega]^2} + \frac{1}{32\pi^2} \|\mathcal{F}_{[\omega]}\|^2 \\ &=: \mathcal{A}([\omega]) \end{aligned}$$

where  $\mathcal{F}$  is Futaki invariant.

$\mathcal{A}$  is function on Kähler cone  $\mathcal{K} \subset H^2(M, \mathbb{R})$ .

## Action Function on Kähler Cone

For any extremal Kähler  $(M^4, h, J)$ ,

$$\begin{aligned}\frac{1}{32\pi^2} \int s^2 d\mu_h &= \frac{(c_1 \cdot [\omega])^2}{[\omega]^2} + \frac{1}{32\pi^2} \|\mathcal{F}_{[\omega]}\|^2 \\ &=: \mathcal{A}([\omega])\end{aligned}$$

where  $\mathcal{F}$  is Futaki invariant.

$\mathcal{A}$  is function on Kähler cone  $\mathcal{K} \subset H^2(M, \mathbb{R})$ .

---

**Lemma.** *If  $h$  is a Kähler metric on a compact complex surface  $(M^4, J)$ , with Kähler class  $[\omega]$ ,*

## Action Function on Kähler Cone

For any extremal Kähler  $(M^4, h, J)$ ,

$$\begin{aligned} \frac{1}{32\pi^2} \int s^2 d\mu_h &= \frac{(c_1 \cdot [\omega])^2}{[\omega]^2} + \frac{1}{32\pi^2} \|\mathcal{F}_{[\omega]}\|^2 \\ &=: \mathcal{A}([\omega]) \end{aligned}$$

where  $\mathcal{F}$  is Futaki invariant.

$\mathcal{A}$  is function on Kähler cone  $\mathcal{K} \subset H^2(M, \mathbb{R})$ .

---

**Lemma.** *If  $h$  is a Kähler metric on a compact complex surface  $(M^4, J)$ , with Kähler class  $[\omega]$ , then  $h$  satisfies  $B = 0 \iff$*

## Action Function on Kähler Cone

For any extremal Kähler  $(M^4, h, J)$ ,

$$\begin{aligned} \frac{1}{32\pi^2} \int s^2 d\mu_h &= \frac{(c_1 \cdot [\omega])^2}{[\omega]^2} + \frac{1}{32\pi^2} \|\mathcal{F}_{[\omega]}\|^2 \\ &=: \mathcal{A}([\omega]) \end{aligned}$$

where  $\mathcal{F}$  is Futaki invariant.

$\mathcal{A}$  is function on Kähler cone  $\mathcal{K} \subset H^2(M, \mathbb{R})$ .

---

**Lemma.** *If  $h$  is a Kähler metric on a compact complex surface  $(M^4, J)$ , with Kähler class  $[\omega]$ , then  $h$  satisfies  $B = 0 \iff$*

- $h$  is an extremal Kähler metric; and

## Action Function on Kähler Cone

For any extremal Kähler  $(M^4, h, J)$ ,

$$\begin{aligned}\frac{1}{32\pi^2} \int s^2 d\mu_h &= \frac{(c_1 \cdot [\omega])^2}{[\omega]^2} + \frac{1}{32\pi^2} \|\mathcal{F}_{[\omega]}\|^2 \\ &=: \mathcal{A}([\omega])\end{aligned}$$

where  $\mathcal{F}$  is Futaki invariant.

$\mathcal{A}$  is function on Kähler cone  $\mathcal{K} \subset H^2(M, \mathbb{R})$ .

---

**Lemma.** *If  $h$  is a Kähler metric on a compact complex surface  $(M^4, J)$ , with Kähler class  $[\omega]$ , then  $h$  satisfies  $B = 0 \iff$*

- $h$  is an extremal Kähler metric; and
- $[\omega]$  is a critical point of  $\mathcal{A} : \mathcal{K} \rightarrow \mathbb{R}$ .

The non-trivial cases are **toric**, and the action  $\mathcal{A}$  can be directly computed from moment polygon.

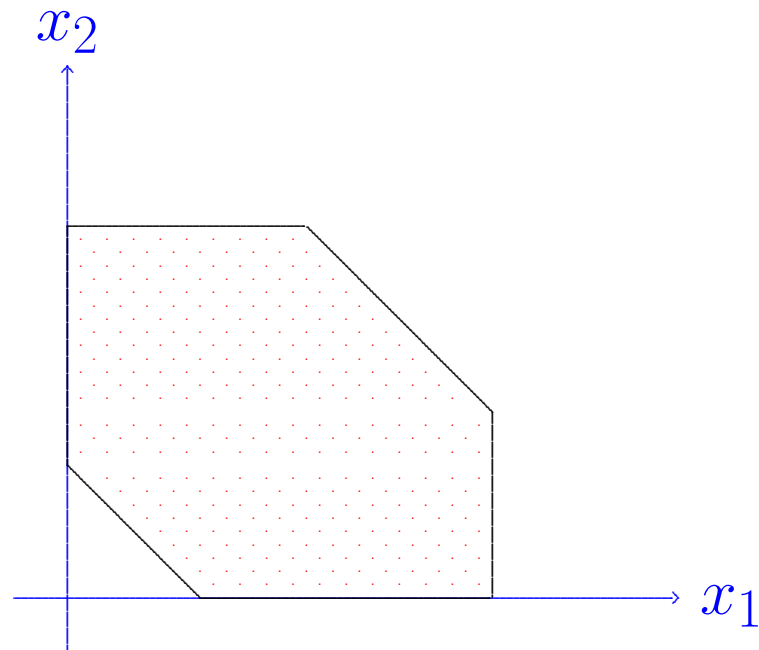

The non-trivial cases are **toric**, and the action  $\mathcal{A}$  can be directly computed from moment polygon. Formula involves barycenters, moments of inertia.

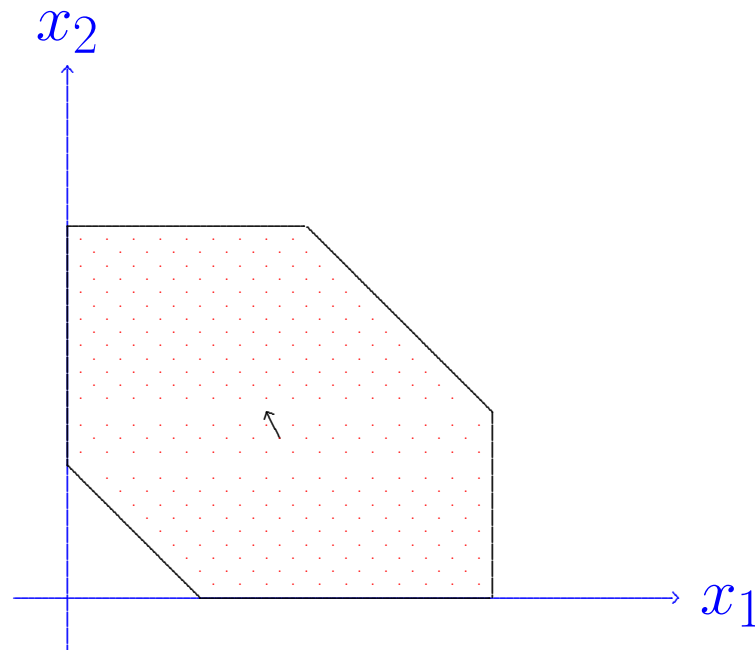

$$\mathcal{A}([\omega]) = \frac{|\partial P|^2}{2} \left( \frac{1}{|P|} + \vec{\mathfrak{D}} \cdot \Pi^{-1} \vec{\mathfrak{D}} \right)$$

To prove Uniqueness, show that

$$\mathcal{A} : \check{\mathcal{K}} \rightarrow \mathbb{R}$$

has unique critical point for relevant  $M$ .

To prove Uniqueness, show that

$$\mathcal{A} : \check{\mathcal{K}} \rightarrow \mathbb{R}$$

has unique critical point for relevant  $M$ .

Here  $\check{\mathcal{K}} = \mathcal{K}/\mathbb{R}^+$ .

To prove Uniqueness, show that

$$\mathcal{A} : \check{\mathcal{K}} \rightarrow \mathbb{R}$$

has unique critical point for relevant  $M$ .

Here  $\check{\mathcal{K}} = \mathcal{K}/\mathbb{R}^+$ .

$\mathcal{A}$  is explicit rational function —

$$\begin{aligned}
& 3[3 + 28\gamma + 96\gamma^2 + 168\gamma^3 + 164\gamma^4 + 80\gamma^5 + 16\gamma^6 + 16\beta^6(1 + \gamma)^4 + 16\alpha^6(1 + \beta + \gamma)^4 + 16\beta^5(5 + 24\gamma + 43\gamma^2 + 37\gamma^3 + 15\gamma^4 + 2\gamma^5) + 4\beta^4(41 + 228\gamma + 478\gamma^2 + 496\gamma^3 + 263\gamma^4 + \\
& 60\gamma^5 + 4\gamma^6) + 8\beta^3(21 + 135\gamma + 326\gamma^2 + 392\gamma^3 + 248\gamma^4 + 74\gamma^5 + 8\gamma^6) + 4\beta(7 + 58\gamma + 176\gamma^2 + 270\gamma^3 + 228\gamma^4 + 96\gamma^5 + 16\gamma^6) + 4\beta^2(24 + 176\gamma + 479\gamma^2 + 652\gamma^3 + 478\gamma^4 + \\
& 172\gamma^5 + 24\gamma^6) + 16\alpha^5(5 + 2\beta^5 + 24\gamma + 43\gamma^2 + 37\gamma^3 + 15\gamma^4 + 2\gamma^5 + \beta^4(15 + 14\gamma) + \beta^3(37 + 70\gamma + 30\gamma^2) + \beta^2(43 + 123\gamma + 108\gamma^2 + 30\gamma^3) + \beta(24 + 92\gamma + 123\gamma^2 + 70\gamma^3 + \\
& 14\gamma^4)) + 4\alpha^4(41 + 4\beta^6 + 228\gamma + 478\gamma^2 + 496\gamma^3 + 263\gamma^4 + 60\gamma^5 + 4\gamma^6 + \beta^5(60 + 56\gamma) + \beta^4(263 + 476\gamma + 196\gamma^2) + 8\beta^3(62 + 169\gamma + 139\gamma^2 + 35\gamma^3) + 2\beta^2(239 + 876\gamma + 1089\gamma^2 + \\
& 556\gamma^3 + 98\gamma^4) + 4\beta(57 + 263\gamma + 438\gamma^2 + 338\gamma^3 + 119\gamma^4 + 14\gamma^5)) + 8\alpha^3(21 + 135\gamma + 326\gamma^2 + 392\gamma^3 + 248\gamma^4 + 74\gamma^5 + 8\gamma^6 + 8\beta^6(1 + \gamma) + 2\beta^5(37 + 70\gamma + 30\gamma^2) + 4\beta^4(62 + \\
& 169\gamma + 139\gamma^2 + 35\gamma^3) + 4\beta^3(98 + 353\gamma + 428\gamma^2 + 210\gamma^3 + 35\gamma^4) + 2\beta^2(163 + 735\gamma + 1179\gamma^2 + 856\gamma^3 + 278\gamma^4 + 30\gamma^5) + \beta(135 + 736\gamma + 1470\gamma^2 + 1412\gamma^3 + 676\gamma^4 + 140\gamma^5 + \\
& 8\gamma^6)) + 4\alpha(7 + 58\gamma + 176\gamma^2 + 270\gamma^3 + 228\gamma^4 + 96\gamma^5 + 16\gamma^6 + 16\beta^6(1 + \gamma)^3 + 4\beta^5(24 + 92\gamma + 123\gamma^2 + 70\gamma^3 + 14\gamma^4) + 4\beta^4(57 + 263\gamma + 438\gamma^2 + 338\gamma^3 + 119\gamma^4 + 14\gamma^5) + \\
& 2\beta^3(135 + 736\gamma + 1470\gamma^2 + 1412\gamma^3 + 676\gamma^4 + 140\gamma^5 + 8\gamma^6) + 4\beta^2(44 + 278\gamma + 645\gamma^2 + 735\gamma^3 + 438\gamma^4 + 123\gamma^5 + 12\gamma^6) + 2\beta(29 + 210\gamma + 556\gamma^2 + 736\gamma^3 + 526\gamma^4 + 184\gamma^5 + \\
& 24\gamma^6)) + 4\alpha^2(24 + 176\gamma + 479\gamma^2 + 652\gamma^3 + 478\gamma^4 + 172\gamma^5 + 24\gamma^6 + 24\beta^6(1 + \gamma)^2 + 4\beta^5(43 + 123\gamma + 108\gamma^2 + 30\gamma^3) + 2\beta^4(239 + 876\gamma + 1089\gamma^2 + 556\gamma^3 + 98\gamma^4) + 4\beta^3(163 + \\
& 735\gamma + 1179\gamma^2 + 856\gamma^3 + 278\gamma^4 + 30\gamma^5) + 4\beta(44 + 278\gamma + 645\gamma^2 + 735\gamma^3 + 438\gamma^4 + 123\gamma^5 + 12\gamma^6) + \beta^2(479 + 2580\gamma + 5058\gamma^2 + 4716\gamma^3 + 2178\gamma^4 + 432\gamma^5 + 24\gamma^6))] / \\
& [1 + 10\gamma + 36\gamma^2 + 64\gamma^3 + 60\gamma^4 + 24\gamma^5 + 24\beta^5(1 + \gamma)^5 + 24\alpha^5(1 + \beta + \gamma)^5 + 12\beta^4(1 + \gamma)^2(5 + 20\gamma + 23\gamma^2 + 10\gamma^3) + 16\beta^3(4 + 28\gamma + 72\gamma^2 + 90\gamma^3 + 57\gamma^4 + 15\gamma^5) + \\
& 12\beta^2(3 + 24\gamma + 69\gamma^2 + 96\gamma^3 + 68\gamma^4 + 20\gamma^5) + 2\beta(5 + 45\gamma + 144\gamma^2 + 224\gamma^3 + 180\gamma^4 + 60\gamma^5) + 12\alpha^4(1 + \beta + \gamma)^2(5 + 20\gamma + 23\gamma^2 + 10\gamma^3 + 10\beta^3(1 + \gamma) + \beta^2(23 + 46\gamma + \\
& 16\gamma^2) + 2\beta(10 + 30\gamma + 23\gamma^2 + 5\gamma^3)) + 16\alpha^3(4 + 28\gamma + 72\gamma^2 + 90\gamma^3 + 57\gamma^4 + 15\gamma^5 + 15\beta^5(1 + \gamma)^2 + 3\beta^4(19 + 57\gamma + 50\gamma^2 + 13\gamma^3) + 3\beta^3(30 + 120\gamma + 155\gamma^2 + 78\gamma^3 + \\
& 13\gamma^4) + 3\beta^2(24 + 120\gamma + 206\gamma^2 + 155\gamma^3 + 50\gamma^4 + 5\gamma^5) + \beta(28 + 168\gamma + 360\gamma^2 + 360\gamma^3 + 171\gamma^4 + 30\gamma^5)) + 12\alpha^2(3 + 24\gamma + 69\gamma^2 + 96\gamma^3 + 68\gamma^4 + 20\gamma^5 + 20\beta^5(1 + \gamma)^3 + \\
& \beta^4(68 + 272\gamma + 366\gamma^2 + 200\gamma^3 + 36\gamma^4) + 4\beta^3(24 + 120\gamma + 206\gamma^2 + 155\gamma^3 + 50\gamma^4 + 5\gamma^5) + 2\beta(12 + 84\gamma + 207\gamma^2 + 240\gamma^3 + 136\gamma^4 + 30\gamma^5) + \beta^2(69 + 414\gamma + 864\gamma^2 + \\
& 824\gamma^3 + 366\gamma^4 + 60\gamma^5)) + 2\alpha(5 + 45\gamma + 144\gamma^2 + 224\gamma^3 + 180\gamma^4 + 60\gamma^5 + 60\beta^5(1 + \gamma)^4 + 12\beta^4(15 + 75\gamma + 136\gamma^2 + 114\gamma^3 + 43\gamma^4 + 5\gamma^5) + 12\beta^2(12 + 84\gamma + 207\gamma^2 + \\
& 240\gamma^3 + 136\gamma^4 + 30\gamma^5) + 8\beta^3(28 + 168\gamma + 360\gamma^2 + 360\gamma^3 + 171\gamma^4 + 30\gamma^5) + 3\beta(15 + 120\gamma + 336\gamma^2 + 448\gamma^3 + 300\gamma^4 + 80\gamma^5))]
\end{aligned}$$

To prove Uniqueness, show that

$$\mathcal{A} : \check{\mathcal{K}} \rightarrow \mathbb{R}$$

has unique critical point for relevant  $M$ .

Here  $\check{\mathcal{K}} = \mathcal{K}/\mathbb{R}^+$ .

$\mathcal{A}$  is explicit rational function —  
but quite complicated!

To prove Uniqueness, show that

$$\mathcal{A} : \check{\mathcal{K}} \rightarrow \mathbb{R}$$

has unique critical point for relevant  $M$ .

Here  $\check{\mathcal{K}} = \mathcal{K}/\mathbb{R}^+$ .

$\mathcal{A}$  is explicit rational function —  
but quite complicated!

Proof proceeds by showing critical point invariant  
under certain discrete automorphisms of  $M$ .

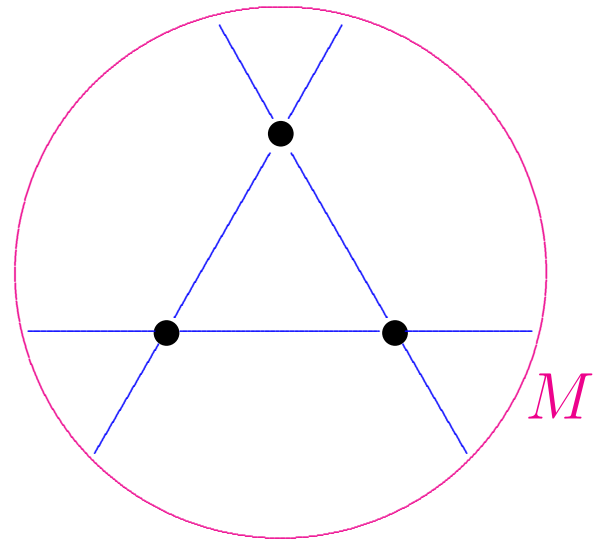

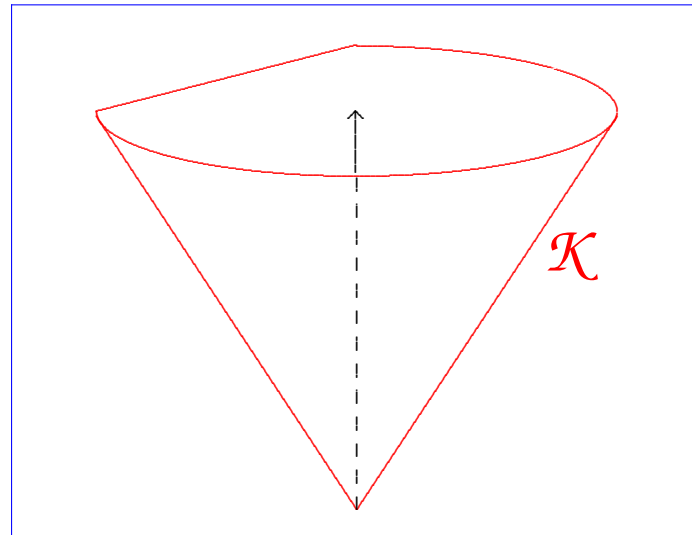
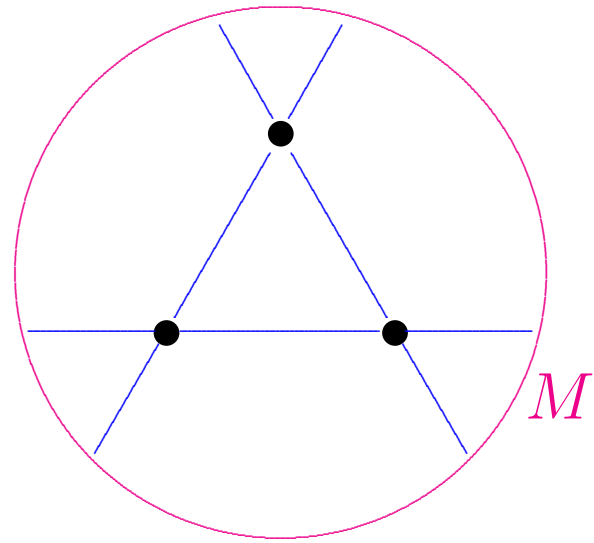

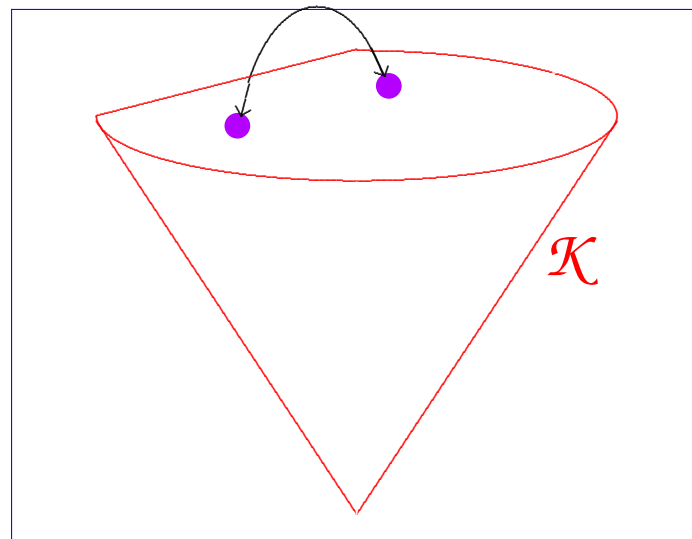
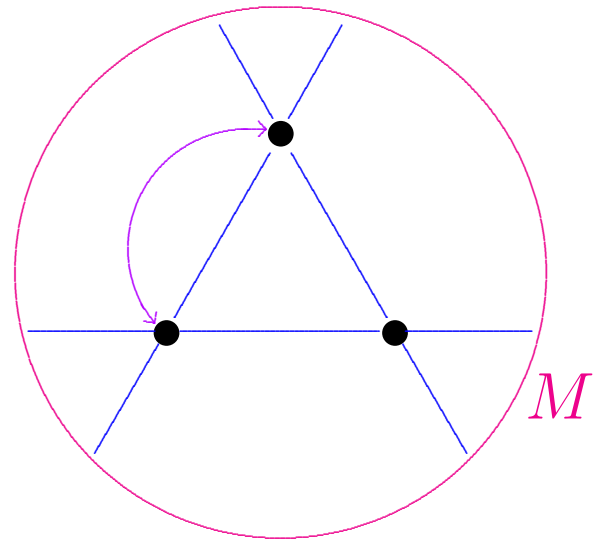

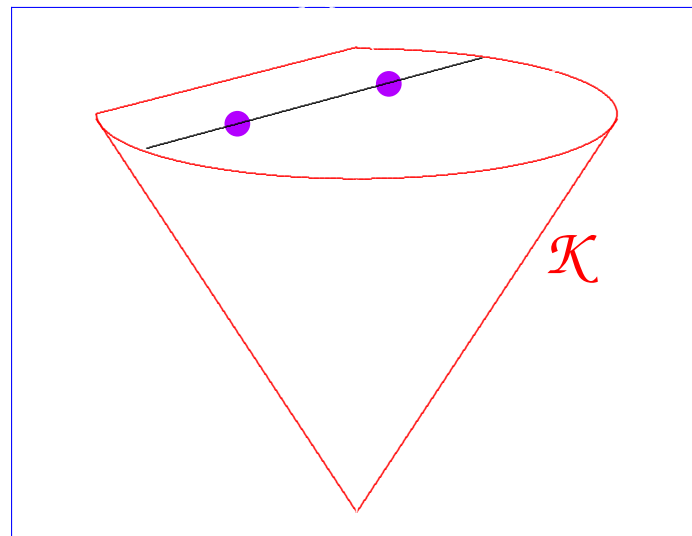
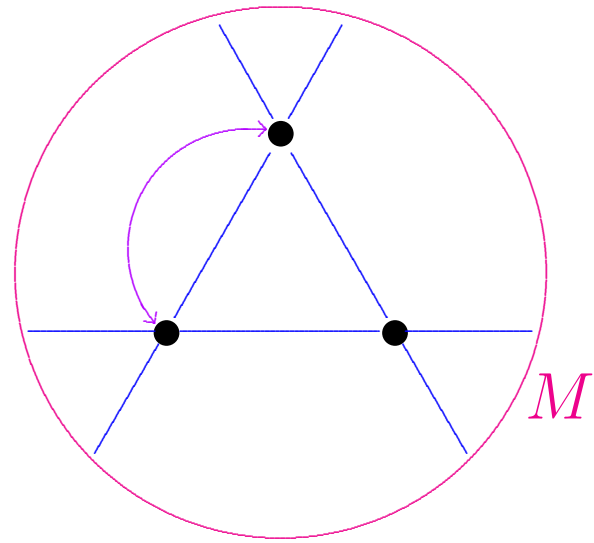

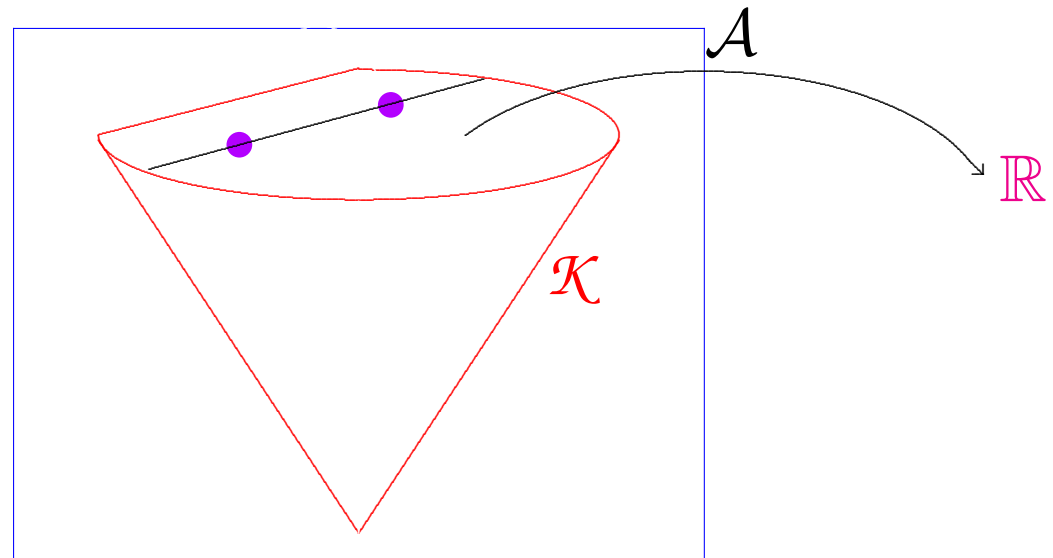
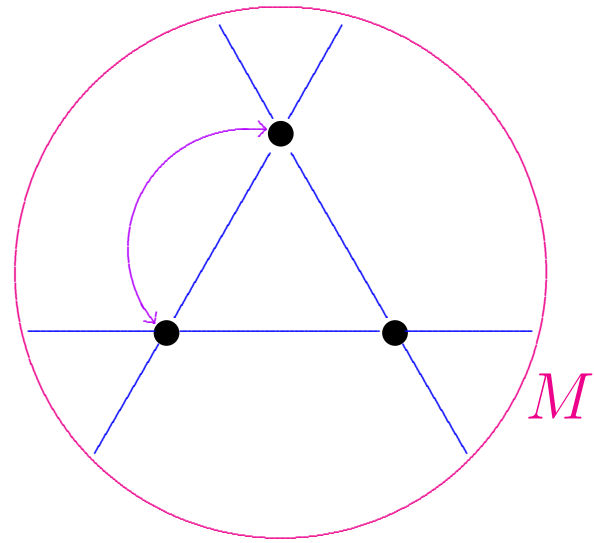

To prove Uniqueness, show that

$$\mathcal{A} : \check{\mathcal{K}} \rightarrow \mathbb{R}$$

has unique critical point for relevant  $M$ .

Here  $\check{\mathcal{K}} = \mathcal{K}/\mathbb{R}^+$ .

$\mathcal{A}$  is explicit rational function —  
but quite complicated!

Proof proceeds by showing critical point invariant  
under certain discrete automorphisms of  $M$ .

Done by showing  $\mathcal{A}$  convex on appropriate lines.

To prove Uniqueness, show that

$$\mathcal{A} : \check{\mathcal{K}} \rightarrow \mathbb{R}$$

has unique critical point for relevant  $M$ .

Here  $\check{\mathcal{K}} = \mathcal{K}/\mathbb{R}^+$ .

$\mathcal{A}$  is explicit rational function —  
but quite complicated!

Proof proceeds by showing critical point invariant  
under certain discrete automorphisms of  $M$ .

Done by showing  $\mathcal{A}$  convex on appropriate lines.

Final step then just calculus in one variable...

One consequence: only Hermitian, Einstein metric on  $\mathbb{C}P_2 \# 3\overline{\mathbb{C}P_2}$  is the Kähler-Einstein metric first discovered by Siu!

One consequence: only Hermitian, Einstein metric on  $\mathbb{C}P_2 \# 3\overline{\mathbb{C}P}_2$  is the Kähler-Einstein metric first discovered by Siu!

But by deforming this metric, one can show that every Kähler class in a specific low-energy conical region on  $\mathbb{C}P_2 \# 3\overline{\mathbb{C}P}_2$  is represented by an **extremal Kähler metric**.

**Theorem.** *Let  $M = \mathbb{C}P_2 \# 3\overline{\mathbb{C}P_2}$  be the blow-up of  $\mathbb{C}P_2$  at three non-collinear points, and let*

**Theorem.** Let  $M = \mathbb{C}P_2 \# 3\overline{\mathbb{C}P_2}$  be the blow-up of  $\mathbb{C}P_2$  at three non-collinear points, and let  $[\omega]$  be a Kähler class on  $M$  for which

$$\mathcal{T}([\omega]) := \frac{(c_1 \cdot [\omega])^2}{[\omega]^2} \leq \frac{3}{2}c_1^2 - \frac{1}{4} = c_1^2 + 2.75.$$

**Theorem.** Let  $M = \mathbb{C}P_2 \# 3\overline{\mathbb{C}P_2}$  be the blow-up of  $\mathbb{C}P_2$  at three non-collinear points, and let  $[\omega]$  be a Kähler class on  $M$  for which

$$\mathcal{T}([\omega]) := \frac{(c_1 \cdot [\omega])^2}{[\omega]^2} \leq \frac{3}{2}c_1^2 - \frac{1}{4} = c_1^2 + 2.75.$$

Then there is an extremal Kähler metric  $h$  on  $M$  with Kähler form  $\omega \in [\omega]$ .

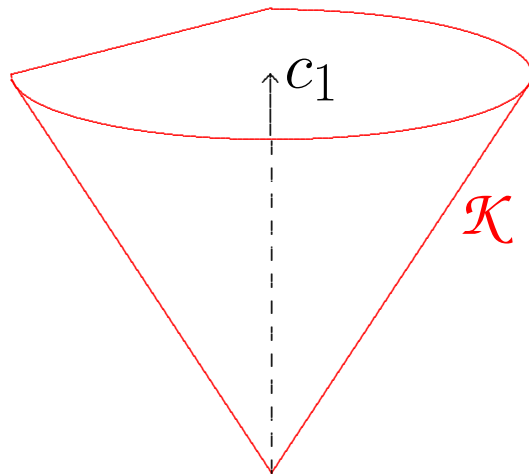

$$H^{1,1}(M, \mathbb{R}) = H^2(M, \mathbb{R})$$

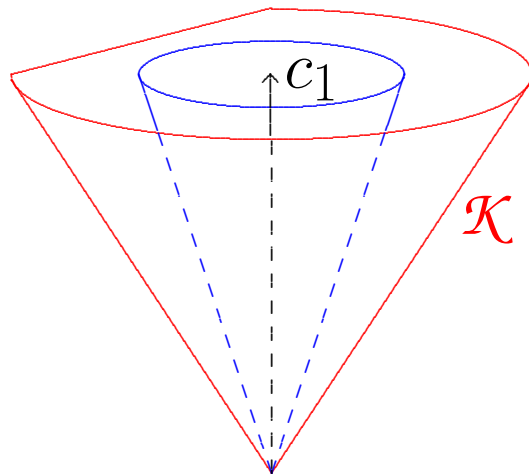

$$\mathcal{T}([\omega]) = \frac{(c_1 \cdot [\omega])^2}{[\omega]^2} \leq \text{const}$$

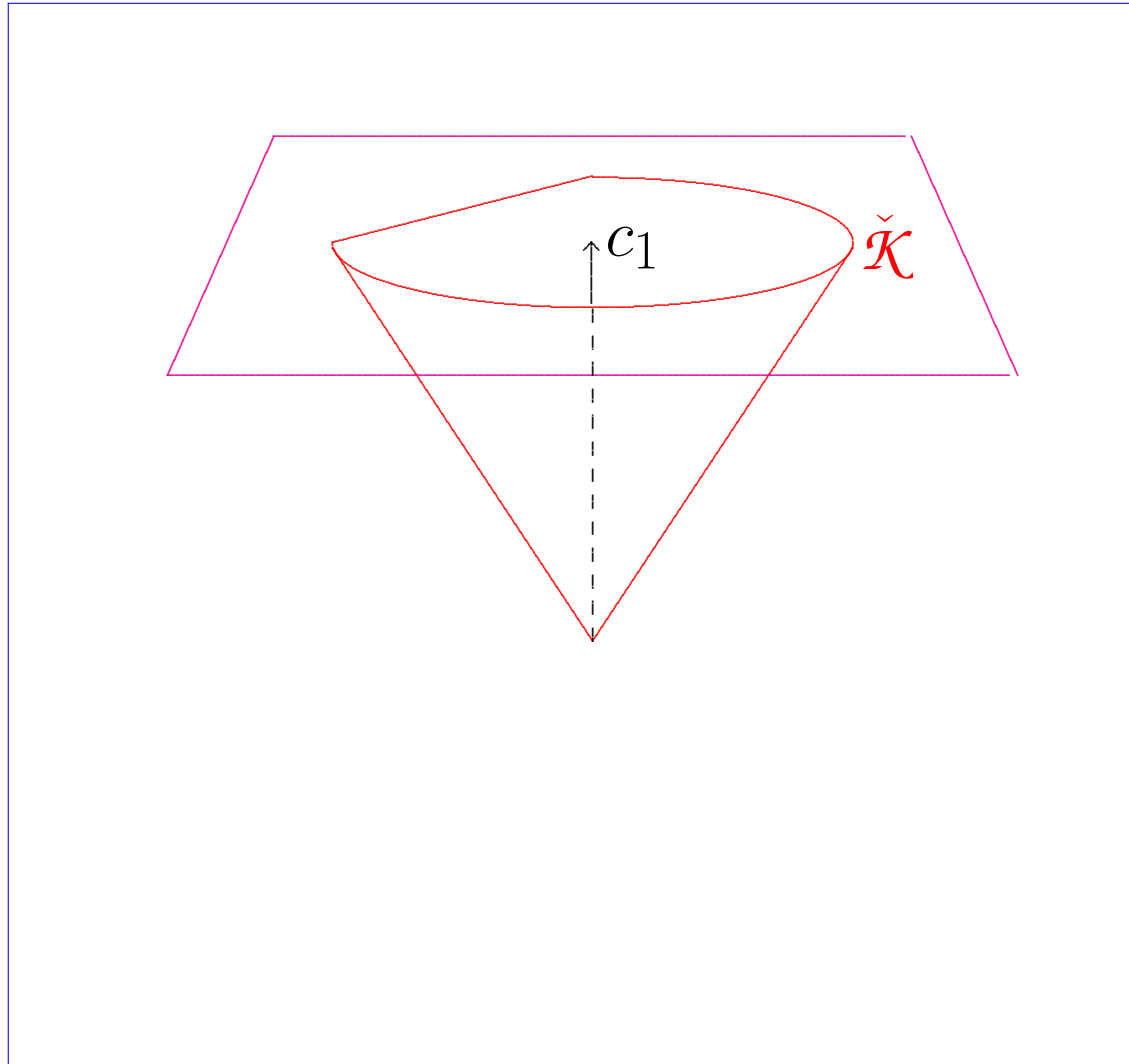

$$\check{\mathcal{K}} = \mathcal{K}/\mathbb{R}^+$$

One consequence: only Hermitian, Einstein metric on  $\mathbb{C}P_2 \# 3\overline{\mathbb{C}P}_2$  is the Kähler-Einstein metric first discovered by Siu!

But by deforming this metric, one can show that every Kähler class in a specific low-energy conical region on  $\mathbb{C}P_2 \# 3\overline{\mathbb{C}P}_2$  is represented by an **extremal Kähler metric**.

One consequence: only Hermitian, Einstein metric on  $\mathbb{C}P_2 \# 3\overline{\mathbb{C}P}_2$  is the Kähler-Einstein metric first discovered by Siu!

But by deforming this metric, one can show that every Kähler class in a specific low-energy conical region on  $\mathbb{C}P_2 \# 3\overline{\mathbb{C}P}_2$  is represented by an **extremal Kähler metric**.

The following result is crucial for this purpose:

**Theorem** (Chen-Weber). *Let  $h_i$  be an arbitrary sequence of unit-volume extremal Kähler metrics on  $M^4$*

**Theorem** (Chen-Weber). *Let  $h_i$  be an arbitrary sequence of unit-volume extremal Kähler metrics on  $M^4$  with uniformly bounded energies  $\mathcal{A}$  and Sobolev constants  $C_S$ .*

**Theorem** (Chen-Weber). *Let  $h_i$  be an arbitrary sequence of unit-volume extremal Kähler metrics on  $M^4$  with uniformly bounded energies  $\mathcal{A}$  and Sobolev constants  $C_S$ . Then  $\exists$  subsequence which Gromov-Hausdorff converges to an extremal Kähler metric on a compact complex orbifold.*

**Theorem** (Chen-Weber). *Let  $h_i$  be an arbitrary sequence of unit-volume extremal Kähler metrics on  $M^4$  with uniformly bounded energies  $\mathcal{A}$  and Sobolev constants  $C_S$ . Then  $\exists$  subsequence which Gromov-Hausdorff converges to an extremal Kähler metric on a compact complex orbifold (of same dimension).*

**Theorem** (Chen-Weber). *Let  $h_i$  be an arbitrary sequence of unit-volume extremal Kähler metrics on  $M^4$  with uniformly bounded energies  $\mathcal{A}$  and Sobolev constants  $C_S$ . Then  $\exists$  subsequence which Gromov-Hausdorff converges to an extremal Kähler metric on a compact complex orbifold.*

Smallest constant such that

$$\|u\|_{L^4}^2 \leq C_S \left( \|\nabla u\|_{L^2}^2 + V^{-1/2} \|u\|_{L^2}^2 \right)$$

**Theorem.** *Let  $h_i$  be an arbitrary sequence of unit-volume extremal Kähler metrics on  $M^4$  with uniformly bounded scalar curvatures  $s$  and Sobolev constants  $C_S$ .*

**Theorem.** *Let  $h_i$  be an arbitrary sequence of unit-volume extremal Kähler metrics on  $M^4$  with uniformly bounded scalar curvatures  $s$  and Sobolev constants  $C_S$ . Then either*

**Theorem.** Let  $h_i$  be an arbitrary sequence of unit-volume extremal Kähler metrics on  $M^4$  with uniformly bounded scalar curvatures  $s$  and Sobolev constants  $C_S$ . Then either

- $\exists$  subsequence which  $C^\infty$  converges modulo diffeomorphisms; or

**Theorem.** Let  $h_i$  be an arbitrary sequence of unit-volume extremal Kähler metrics on  $M^4$  with uniformly bounded scalar curvatures  $s$  and Sobolev constants  $C_S$ . Then either

- $\exists$  subsequence which  $C^\infty$  converges modulo diffeomorphisms; or
- $\exists$  pointed G-H limit of rescalings which is a non-trivial ALE scalar-flat Kähler manifold.

**Theorem.** Let  $h_i$  be an arbitrary sequence of unit-volume extremal Kähler metrics on  $M^4$  with uniformly bounded scalar curvatures  $s$  and Sobolev constants  $C_S$ . Then either

- $\exists$  subsequence which  $C^\infty$  converges modulo diffeomorphisms; or
- $\exists$  pointed G-H limit of rescalings which is a non-trivial *ALE scalar-flat Kähler manifold*.

“Deepest bubble”

**Theorem.** Let  $h_i$  be an arbitrary sequence of unit-volume extremal Kähler metrics on  $M^4$  with uniformly bounded scalar curvatures  $s$  and Sobolev constants  $C_S$ . Then either

- $\exists$  subsequence which  $C^\infty$  converges modulo diffeomorphisms; or
- $\exists$  pointed G-H limit of rescalings which is a non-trivial *ALE scalar-flat Kähler manifold*.

“Deepest bubble”

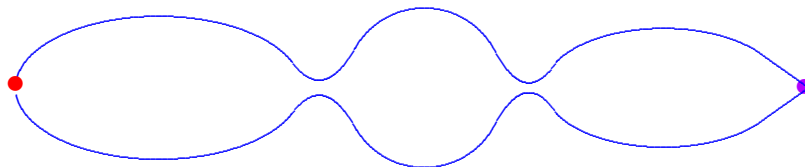

**Theorem.** Let  $h_i$  be an arbitrary sequence of unit-volume extremal Kähler metrics on  $M^4$  with uniformly bounded scalar curvatures  $s$  and Sobolev constants  $C_S$ . Then either

- $\exists$  subsequence which  $C^\infty$  converges modulo diffeomorphisms; or
- $\exists$  pointed G-H limit of rescalings which is a non-trivial *ALE scalar-flat Kähler manifold*.

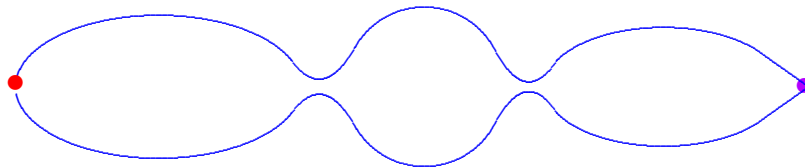

**Theorem.** Let  $h_i$  be an arbitrary sequence of unit-volume extremal Kähler metrics on  $M^4$  with uniformly bounded scalar curvatures  $s$  and Sobolev constants  $C_S$ . Then either

- $\exists$  subsequence which  $C^\infty$  converges modulo diffeomorphisms; or
- $\exists$  pointed G-H limit of rescalings which is a non-trivial *ALE scalar-flat Kähler manifold*.

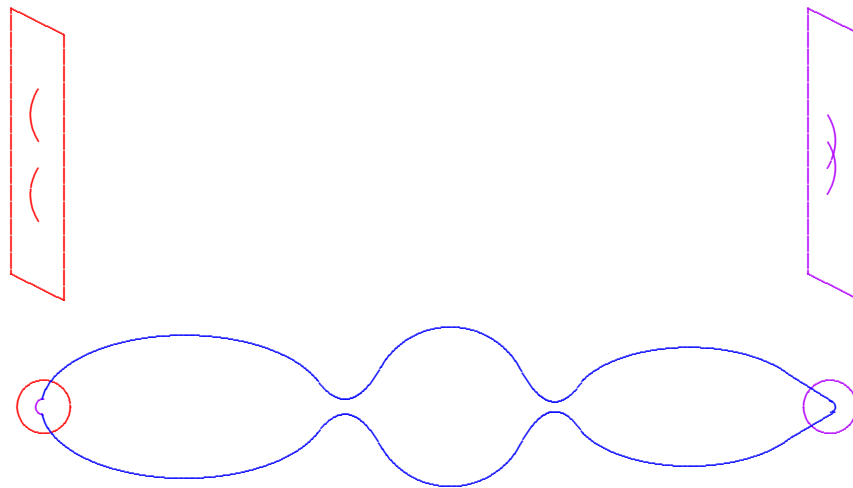

**Theorem.** Let  $h_i$  be an arbitrary sequence of unit-volume extremal Kähler metrics on Del Pezzo  $M$  which satisfy

$$\mathcal{T}([\omega]) \leq \frac{3}{2}c_1^2 - \frac{1}{4}$$

Then  $\exists$  subsequence which Gromov-Hausdorff converges to an extremal Kähler metric on a compact complex 2-orbifold.

**Theorem.** Let  $h_i$  be an arbitrary sequence of unit-volume extremal Kähler metrics on Del Pezzo  $M$  which satisfy

$$\mathcal{T}([\omega]) \leq \frac{3}{2}c_1^2 - \frac{1}{4}$$

Then  $\exists$  subsequence which Gromov-Hausdorff converges to an extremal Kähler metric on a compact complex 2-orbifold.

**Theorem.** Set of  $[\omega] \in \mathcal{K}$  containing extremal Kähler metric is open.

**Theorem.** Let  $h_i$  be an arbitrary sequence of unit-volume extremal Kähler metrics on Del Pezzo  $M$  which satisfy

$$\mathcal{T}([\omega]) \leq \frac{3}{2}c_1^2 - \frac{1}{4}$$

Then  $\exists$  subsequence which Gromov-Hausdorff converges to an extremal Kähler metric on a compact complex 2-orbifold.

**Theorem.** Set of  $[\omega] \in \mathcal{K}$  containing extremal Kähler metric is *open*.

Suggests continuity method...

**Theorem.** Let  $h_i$  be an arbitrary sequence of unit-volume extremal Kähler metrics on Del Pezzo  $M$  which satisfy

$$\mathcal{T}([\omega]) \leq \frac{3}{2}c_1^2 - \frac{1}{4}$$

Then  $\exists$  subsequence which Gromov-Hausdorff converges to an extremal Kähler metric on a compact complex 2-orbifold.

Difficulty: rule out deepest bubbles.

**Lemma.** *If  $M$  is toric, any deepest bubble  $(X, h_\infty)$  must be toric, too, with  $H_2(X, \mathbb{R}) \neq 0$  generated by holomorphic  $\mathbb{C}P_1$ 's.*

**Lemma.** *If  $M$  is toric, any deepest bubble  $(X, h_\infty)$  must be toric, too, with  $H_2(X, \mathbb{R}) \neq 0$  generated by holomorphic  $\mathbb{C}P_1$ 's.*

Moment map profile:

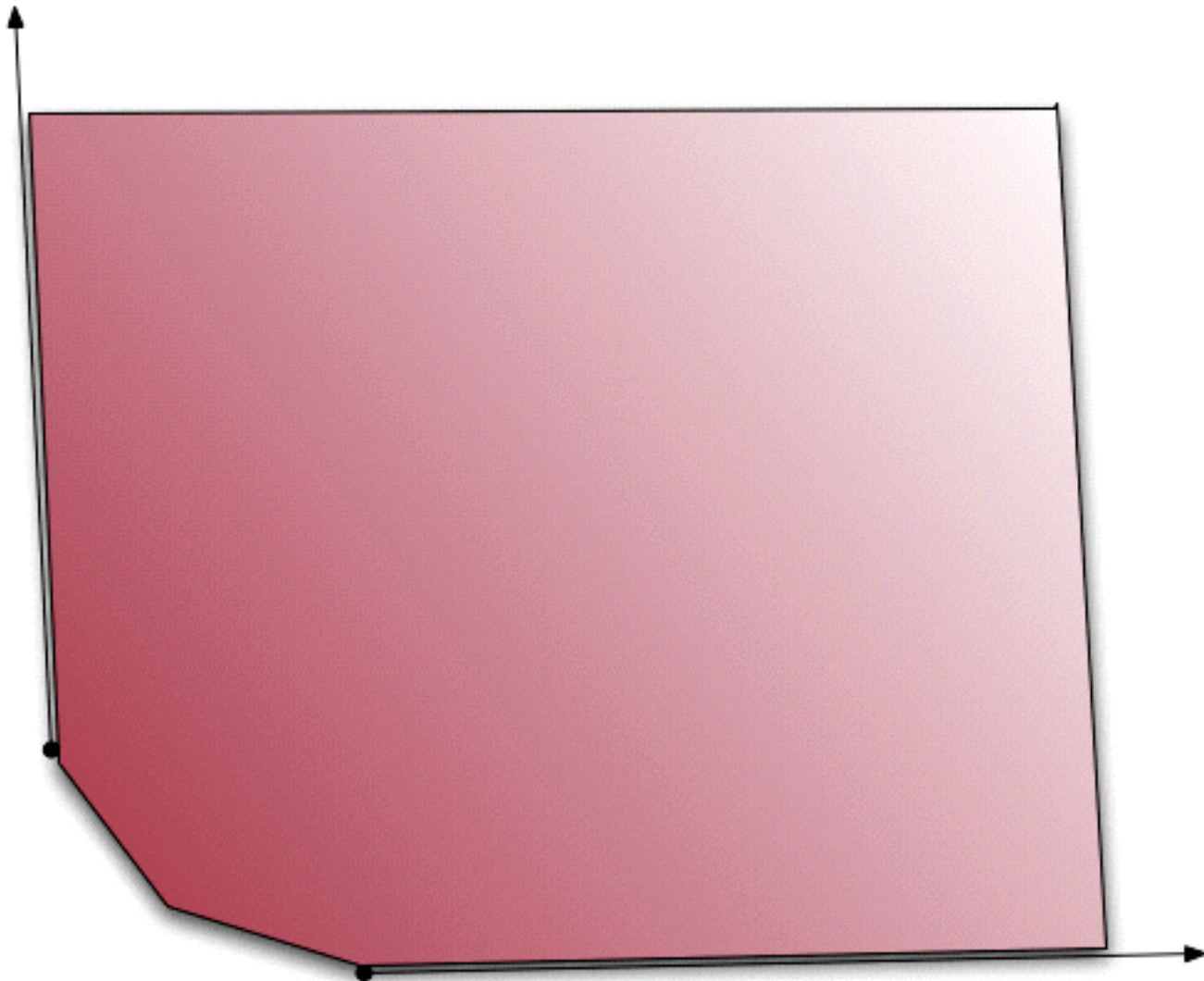

- Bubble arises by **rescaling** region of manifold by scales  $\nearrow \infty$ .

- Bubble arises by rescaling region of manifold by scales  $\nearrow \infty$ .
- Limit  $X$  has negative intersection form.

- Bubble arises by rescaling region of manifold by scales  $\nearrow \infty$ .
- Limit  $X$  has negative intersection form.
- Limit holomorphic  $\mathbb{C}\mathbb{P}_1$  arises from symplectic  $S^2 \subset M$ .

- Bubble arises by rescaling region of manifold by scales  $\nearrow \infty$ .
- Limit  $X$  has negative intersection form.
- Limit holomorphic  $\mathbb{C}\mathbb{P}_1$  arises from symplectic  $S^2 \subset M$ .

**Lemma.** *For toric Del Pezzo  $M$ , if bubbling occurs as  $[\omega_j] \rightarrow \Omega$  in controlled cone, then there exists  $[S] \in H_2(M, \mathbb{Z})$*

- Bubble arises by rescaling region of manifold by scales  $\nearrow \infty$ .
- Limit  $X$  has negative intersection form.
- Limit holomorphic  $\mathbb{C}\mathbb{P}_1$  arises from symplectic  $S^2 \subset M$ .

**Lemma.** *For toric Del Pezzo  $M$ , if bubbling occurs as  $[\omega_j] \rightarrow \Omega$  in controlled cone, then there exists  $[S] \in H_2(M, \mathbb{Z})$  with*

$$[S] \cdot [S] = -k < 0$$

- Bubble arises by rescaling region of manifold by scales  $\nearrow \infty$ .
- Limit  $X$  has negative intersection form.
- Limit holomorphic  $\mathbb{C}\mathbb{P}_1$  arises from symplectic  $S^2 \subset M$ .

**Lemma.** *For toric Del Pezzo  $M$ , if bubbling occurs as  $[\omega_j] \rightarrow \Omega$  in controlled cone, then there exists  $[S] \in H_2(M, \mathbb{Z})$  with*

$$[S] \cdot [S] = -k < 0$$

$$c_1 \cdot [S] = 2 - k$$

- Bubble arises by rescaling region of manifold by scales  $\nearrow \infty$ .
- Limit  $X$  has negative intersection form.
- Limit holomorphic  $\mathbb{C}\mathbb{P}_1$  arises from symplectic  $S^2 \subset M$ .

**Lemma.** *For toric Del Pezzo  $M$ , if bubbling occurs as  $[\omega_j] \rightarrow \Omega$  in controlled cone, then there exists  $[S] \in H_2(M, \mathbb{Z})$  with*

$$[S] \cdot [S] = -k < 0$$

$$c_1 \cdot [S] = 2 - k$$

$$\Omega \cdot [S] = 0$$

Now suppose that  $c_1 \in \mathcal{K}$  on toric Del Pezzo  $M$  represented by extremal Kähler metric. Suppose that  $[\omega]$  satisfies

$$\mathcal{T}([\omega]) \leq \frac{3}{2}c_1^2 - \frac{1}{4}$$

Now suppose that  $c_1 \in \mathcal{K}$  on toric Del Pezzo  $M$  represented by extremal Kähler metric. Suppose that  $[\omega]$  satisfies

$$\mathcal{T}([\omega]) \leq \frac{3}{2}c_1^2 - \frac{1}{4}$$

Consider line segment

$$[\omega_t] = (1 - t)c_1 + t[\omega]$$

of Kähler classes,

Now suppose that  $c_1 \in \mathcal{K}$  on toric Del Pezzo  $M$  represented by extremal Kähler metric. Suppose that  $[\omega]$  satisfies

$$\mathcal{T}([\omega]) \leq \frac{3}{2}c_1^2 - \frac{1}{4}$$

Consider line segment

$$[\omega_t] = (1 - t)c_1 + t[\omega]$$

of Kähler classes, and suppose extremal metric exists for  $t \in [0, \mathfrak{t})$ .

Now suppose that  $c_1 \in \mathcal{K}$  on toric Del Pezzo  $M$  represented by extremal Kähler metric. Suppose that  $[\omega]$  satisfies

$$\mathcal{T}([\omega]) \leq \frac{3}{2}c_1^2 - \frac{1}{4}$$

Consider line segment

$$[\omega_t] = (1 - t)c_1 + t[\omega]$$

of Kähler classes, and suppose extremal metric exists for  $t \in [0, \mathfrak{t})$ . If bubbling occurred for  $t_j \nearrow \mathfrak{t}$ , then, setting  $\Omega = [\omega_{\mathfrak{t}}]$ , would have  $[S] \in H_2(M, \mathbb{Z})$

Now suppose that  $c_1 \in \mathcal{K}$  on toric Del Pezzo  $M$  represented by extremal Kähler metric. Suppose that  $[\omega]$  satisfies

$$\mathcal{T}([\omega]) \leq \frac{3}{2}c_1^2 - \frac{1}{4}$$

Consider line segment

$$[\omega_t] = (1 - t)c_1 + t[\omega]$$

of Kähler classes, and suppose extremal metric exists for  $t \in [0, \mathfrak{t})$ . If bubbling occurred for  $t_j \nearrow \mathfrak{t}$ , then, setting  $\Omega = [\omega_{\mathfrak{t}}]$ , would have  $[S] \in H_2(M, \mathbb{Z})$  with

$$[\omega_{t_j}] \cdot [S] > 0$$

Now suppose that  $c_1 \in \mathcal{K}$  on toric Del Pezzo  $M$  represented by extremal Kähler metric. Suppose that  $[\omega]$  satisfies

$$\mathcal{T}([\omega]) \leq \frac{3}{2}c_1^2 - \frac{1}{4}$$

Consider line segment

$$[\omega_t] = (1 - t)c_1 + t[\omega]$$

of Kähler classes, and suppose extremal metric exists for  $t \in [0, \mathfrak{t})$ . If bubbling occurred for  $t_j \nearrow \mathfrak{t}$ , then, setting  $\Omega = [\omega_{\mathfrak{t}}]$ , would have  $[S] \in H_2(M, \mathbb{Z})$  with

$$\begin{aligned} [\omega_{t_j}] \cdot [S] &> 0 \\ [S] \cdot [S] &= -k < 0 \\ c_1 \cdot [S] &= 2 - k \\ \Omega \cdot [S] &= 0 \end{aligned}$$

Now suppose that  $c_1 \in \mathcal{K}$  on toric Del Pezzo  $M$  represented by extremal Kähler metric. Suppose that  $[\omega]$  satisfies

$$\mathcal{T}([\omega]) \leq \frac{3}{2}c_1^2 - \frac{1}{4}$$

Consider line segment

$$[\omega_t] = (1 - t)c_1 + t[\omega]$$

of Kähler classes, and suppose extremal metric exists for  $t \in [0, \mathfrak{t})$ . If bubbling occurred for  $t_j \nearrow \mathfrak{t}$ , then, setting  $\Omega = [\omega_{\mathfrak{t}}]$ , would have  $[S] \in H_2(M, \mathbb{Z})$  with

$$\begin{aligned} (u_j c_1 + v_j \Omega) \cdot [S] &> 0, \quad \exists u_j, v_j > 0 \\ [S] \cdot [S] &= -k < 0 \\ c_1 \cdot [S] &= 2 - k \\ \Omega \cdot [S] &= 0 \end{aligned}$$

Now suppose that  $c_1 \in \mathcal{K}$  on toric Del Pezzo  $M$  represented by extremal Kähler metric. Suppose that  $[\omega]$  satisfies

$$\mathcal{T}([\omega]) \leq \frac{3}{2}c_1^2 - \frac{1}{4}$$

Consider line segment

$$[\omega_t] = (1 - t)c_1 + t[\omega]$$

of Kähler classes, and suppose extremal metric exists for  $t \in [0, \mathfrak{t})$ . If bubbling occurred for  $t_j \nearrow \mathfrak{t}$ , then, setting  $\Omega = [\omega_{\mathfrak{t}}]$ , would have  $[S] \in H_2(M, \mathbb{Z})$  with

$$\begin{aligned} u_j c_1 \cdot [S] &> 0, \quad \exists u_j > 0 \\ [S] \cdot [S] &= -k < 0 \\ c_1 \cdot [S] &= 2 - k \\ \Omega \cdot [S] &= 0 \end{aligned}$$

Now suppose that  $c_1 \in \mathcal{K}$  on toric Del Pezzo  $M$  represented by extremal Kähler metric. Suppose that  $[\omega]$  satisfies

$$\mathcal{T}([\omega]) \leq \frac{3}{2}c_1^2 - \frac{1}{4}$$

Consider line segment

$$[\omega_t] = (1 - t)c_1 + t[\omega]$$

of Kähler classes, and suppose extremal metric exists for  $t \in [0, \mathfrak{t})$ . If bubbling occurred for  $t_j \nearrow \mathfrak{t}$ , then, setting  $\Omega = [\omega_{\mathfrak{t}}]$ , would have  $[S] \in H_2(M, \mathbb{Z})$  with

$$\begin{aligned} c_1 \cdot [S] &> 0, \\ [S] \cdot [S] &= -k < 0 \\ c_1 \cdot [S] &= 2 - k \\ \Omega \cdot [S] &= 0 \end{aligned}$$

Now suppose that  $c_1 \in \mathcal{K}$  on toric Del Pezzo  $M$  represented by extremal Kähler metric. Suppose that  $[\omega]$  satisfies

$$\mathcal{T}([\omega]) \leq \frac{3}{2}c_1^2 - \frac{1}{4}$$

Consider line segment

$$[\omega_t] = (1 - t)c_1 + t[\omega]$$

of Kähler classes, and suppose extremal metric exists for  $t \in [0, \mathfrak{t})$ . If bubbling occurred for  $t_j \nearrow \mathfrak{t}$ , then, setting  $\Omega = [\omega_{\mathfrak{t}}]$ , would have  $[S] \in H_2(M, \mathbb{Z})$  with

$$[S] \cdot [S] = -1$$

$$c_1 \cdot [S] = 1$$

$$\Omega \cdot [S] = 0$$

Now suppose that  $c_1 \in \mathcal{K}$  on toric Del Pezzo  $M$  represented by extremal Kähler metric. Suppose that  $[\omega]$  satisfies

$$\mathcal{T}([\omega]) \leq \frac{3}{2}c_1^2 - \frac{1}{4}$$

Consider line segment

$$[\omega_t] = (1 - t)c_1 + t[\omega]$$

of Kähler classes, and suppose extremal metric exists for  $t \in [0, \mathfrak{t})$ . If bubbling occurred for  $t_j \nearrow \mathfrak{t}$ , then, setting  $\Omega = [\omega_{\mathfrak{t}}]$ , would have  $[S] \in H_2(M, \mathbb{Z})$  represented by holomorphic  $(-1)$ -curve with

$$\Omega \cdot [S] = 0$$

Now suppose that  $c_1 \in \mathcal{K}$  on toric Del Pezzo  $M$  represented by extremal Kähler metric. Suppose that  $[\omega]$  satisfies

$$\mathcal{T}([\omega]) \leq \frac{3}{2}c_1^2 - \frac{1}{4}$$

Consider line segment

$$[\omega_t] = (1 - t)c_1 + t[\omega]$$

of Kähler classes, and suppose extremal metric exists for  $t \in [0, \mathfrak{t})$ . If bubbling occurred for  $t_j \nearrow \mathfrak{t}$ , then, setting  $\Omega = [\omega_{\mathfrak{t}}]$ , would have  $[S] \in H_2(M, \mathbb{Z})$  represented by holomorphic  $(-1)$ -curve with

$$\Omega \cdot [S] = 0$$

It follows that bubbling off cannot occur!

One consequence: only Hermitian, Einstein metric on  $\mathbb{C}P_2 \# \overline{3\mathbb{C}P_2}$  is the Kähler-Einstein metric first discovered by Siu!

But by deforming this metric, one can show that every Kähler class in a specific low-energy conical region on  $\mathbb{C}P_2 \# \overline{3\mathbb{C}P_2}$  is represented by an **extremal Kähler metric**.

One consequence: only Hermitian, Einstein metric on  $\mathbb{C}P_2 \# 3\overline{\mathbb{C}P_2}$  is the Kähler-Einstein metric first discovered by Siu!

But by deforming this metric, one can show that every Kähler class in a specific low-energy conical region on  $\mathbb{C}P_2 \# 3\overline{\mathbb{C}P_2}$  is represented by an **extremal Kähler metric**.

Weak limits of these metrics show that the target class on  $\mathbb{C}P_2 \# 2\overline{\mathbb{C}P_2}$  is also represented by an extremal Kähler metric, and the promised Einstein metric on  $\mathbb{C}P_2 \# 2\overline{\mathbb{C}P_2}$  is a conformal rescaling of this extremal Kähler metric.

**Theorem.** Let  $M = \mathbb{C}P_2 \# 3\overline{\mathbb{C}P_2}$  be the blow-up of  $\mathbb{C}P_2$  at three non-collinear points, and let  $[\omega]$  be a Kähler class on  $M$  for which

$$\mathcal{T}([\omega]) := \frac{(c_1 \cdot [\omega])^2}{[\omega]^2} \leq \frac{3}{2}c_1^2 - \frac{1}{4} = c_1^2 + 2.75.$$

Then there is an extremal Kähler metric  $h$  on  $M$  with Kähler form  $\omega \in [\omega]$ .

**Theorem.** Let  $M = \mathbb{C}P_2 \# 3\overline{\mathbb{C}P_2}$  be the blow-up of  $\mathbb{C}P_2$  at three non-collinear points, and let  $[\omega]$  be a Kähler class on  $M$  for which

$$\mathcal{T}([\omega]) := \frac{(c_1 \cdot [\omega])^2}{[\omega]^2} \leq \frac{3}{2}c_1^2 - \frac{1}{4} = c_1^2 + 2.75.$$

Then there is an extremal Kähler metric  $h$  on  $M$  with Kähler form  $\omega \in [\omega]$ .

Also works when approaching boundary of Kähler cone, but can bubble off  $(-1)$ -curves.

**Theorem.** *Let  $\Omega$  be any Kähler class on  $\mathbb{C}P_2 \# 2\overline{\mathbb{C}P_2}$  for which*

$$\mathcal{T}(\Omega) < 8.75 = c_1^2 + 1.75 .$$

**Theorem.** *Let  $\Omega$  be any Kähler class on  $\mathbb{C}P_2 \# 2\overline{\mathbb{C}P_2}$  for which*

$$\mathcal{T}(\Omega) < 8.75 = c_1^2 + 1.75 .$$

*Then there is an extremal Kähler metric  $h$  in  $\Omega$ ,*

**Theorem.** Let  $\Omega$  be any Kähler class on  $\mathbb{C}P_2 \# 2\overline{\mathbb{C}P_2}$  for which

$$\mathcal{T}(\Omega) < 8.75 = c_1^2 + 1.75 .$$

Then there is an extremal Kähler metric  $h$  in  $\Omega$ , and a 1-parameter family

$$[0, 1) \ni t \longmapsto h_t$$

of extremal Kähler metrics on  $\mathbb{C}P_2 \# 3\overline{\mathbb{C}P_2}$

**Theorem.** Let  $\Omega$  be any Kähler class on  $\mathbb{C}P_2 \# 2\overline{\mathbb{C}P_2}$  for which

$$\mathcal{T}(\Omega) < 8.75 = c_1^2 + 1.75 .$$

Then there is an extremal Kähler metric  $h$  in  $\Omega$ , and a 1-parameter family

$$[0, 1) \ni t \longmapsto h_t$$

of extremal Kähler metrics on  $\mathbb{C}P_2 \# 3\overline{\mathbb{C}P_2}$  s.t.

- $h_0$  is Kähler-Einstein, and such that
- $h_{t_j} \rightarrow h$  in the Gromov-Hausdorff sense for some  $t_j \nearrow 1$ .

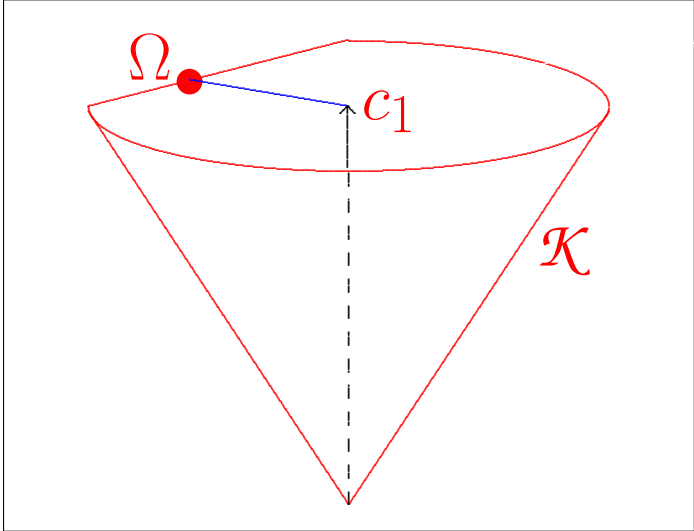

**Theorem.** *There is a conformally Kähler, Einstein metric  $g$  on  $M = \mathbb{C}P_2 \# 2\overline{\mathbb{C}P_2}$*

**Theorem.** *There is a conformally Kähler, Einstein metric  $g$  on  $M = \mathbb{C}P_2 \# 2\overline{\mathbb{C}P_2}$  for which the conformally related Kähler  $h$*

**Theorem.** *There is a conformally Kähler, Einstein metric  $g$  on  $M = \mathbb{C}P_2 \# 2\overline{\mathbb{C}P_2}$  for which the conformally related Kähler  $h$  minimizes the functional*

$$h \longmapsto \int_M s^2 d\mu_h$$

*among all Kähler metrics on  $M$ .*

**Theorem.** *There is a conformally Kähler, Einstein metric  $g$  on  $M = \mathbb{C}P_2 \# 2\overline{\mathbb{C}P}_2$  for which the conformally related Kähler  $h$  minimizes the functional*

$$h \longmapsto \int_M s^2 d\mu_h$$

*among all Kähler metrics on  $M$ . Consequently,  $g$  is an absolute minimizer of the functional*

$$g \longmapsto \int_M |W|_g^2 d\mu_g.$$

*among all conformally Kähler metrics on  $M$ .*

**Theorem.** *This minimizing Kähler metric  $h$  on  $\mathbb{C}P_2 \# 2\overline{\mathbb{C}P}_2$  is conformal to an Einstein metric.*

**Theorem.** *This minimizing Kähler metric  $h$  on  $\mathbb{C}P_2 \# 2\overline{\mathbb{C}P_2}$  is conformal to an Einstein metric. Moreover, there is a 1-parameter family*

$$[0, 1) \ni t \longmapsto h_t$$

*of extremal Kähler metrics on  $\mathbb{C}P_2 \# 3\overline{\mathbb{C}P_2}$*

**Theorem.** *This minimizing Kähler metric  $h$  on  $\mathbb{C}P_2 \# 2\overline{\mathbb{C}P_2}$  is conformal to an Einstein metric. Moreover, there is a 1-parameter family*

$$[0, 1) \ni t \longmapsto h_t$$

*of extremal Kähler metrics on  $\mathbb{C}P_2 \# 3\overline{\mathbb{C}P_2}$  s.t.*

- *$h_0$  is Kähler-Einstein,*

**Theorem.** *This minimizing Kähler metric  $h$  on  $\mathbb{C}P_2 \# 2\overline{\mathbb{C}P_2}$  is conformal to an Einstein metric. Moreover, there is a 1-parameter family*

$$[0, 1) \ni t \longmapsto h_t$$

*of extremal Kähler metrics on  $\mathbb{C}P_2 \# 3\overline{\mathbb{C}P_2}$  s.t.*

- $h_0$  is Kähler-Einstein, and such that
- $h_{t_j} \rightarrow h$  in the Gromov-Hausdorff sense

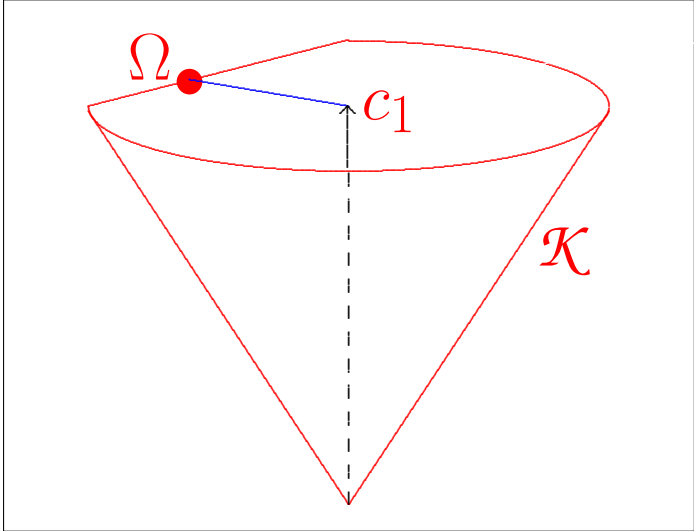

**Theorem.** *This minimizing Kähler metric  $h$  on  $\mathbb{C}P_2 \# 2\overline{\mathbb{C}P_2}$  is conformal to an Einstein metric. Moreover, there is a 1-parameter family*

$$[0, 1) \ni t \longmapsto h_t$$

*of extremal Kähler metrics on  $\mathbb{C}P_2 \# 3\overline{\mathbb{C}P_2}$  s.t.*

- $h_0$  is Kähler-Einstein, and such that
- $h_{t_j} \rightarrow h$  in the Gromov-Hausdorff sense for some  $t_j \nearrow 1$ .

**Theorem.** *This minimizing Kähler metric  $h$  on  $\mathbb{C}P_2 \# 2\overline{\mathbb{C}P_2}$  is conformal to an Einstein metric. Moreover, there is a 1-parameter family*

$$[0, 1) \ni t \longmapsto h_t$$

*of extremal Kähler metrics on  $\mathbb{C}P_2 \# 3\overline{\mathbb{C}P_2}$  s.t.*

- $h_0$  is Kähler-Einstein, and such that
- $h_{t_j} \rightarrow h$  in the Gromov-Hausdorff sense for some  $t_j \nearrow 1$ .

Similarly for  $\mathbb{C}P_2 \# \overline{\mathbb{C}P_2}$ , though less interesting...

One consequence: only Hermitian, Einstein metric on  $\mathbb{C}P_2 \# 3\overline{\mathbb{C}P}_2$  is the Kähler-Einstein metric first discovered by Siu!

But by deforming this metric, one can show that every Kähler class in a specific low-energy conical region on  $\mathbb{C}P_2 \# 3\overline{\mathbb{C}P}_2$  is represented by an **extremal Kähler metric**.

Weak limits of these metrics show that the target class on  $\mathbb{C}P_2 \# 2\overline{\mathbb{C}P}_2$  is also represented by an extremal Kähler metric, and the promised Einstein metric on  $\mathbb{C}P_2 \# 2\overline{\mathbb{C}P}_2$  is a conformal rescaling of this extremal Kähler metric.

One consequence: only Hermitian, Einstein metric on  $\mathbb{C}P_2 \# 3\overline{\mathbb{C}P_2}$  is the Kähler-Einstein metric first discovered by Siu!

But by deforming this metric, one can show that every Kähler class in a specific low-energy conical region on  $\mathbb{C}P_2 \# 3\overline{\mathbb{C}P_2}$  is represented by an **extremal Kähler metric**.

Weak limits of these metrics show that the target class on  $\mathbb{C}P_2 \# 2\overline{\mathbb{C}P_2}$  is also represented by an extremal Kähler metric, and the promised Einstein metric on  $\mathbb{C}P_2 \# 2\overline{\mathbb{C}P_2}$  is a conformal rescaling of this extremal Kähler metric.

This approach was carried out in L '13, and gives a technically simpler alternative to the previous existence proof given in Chen-L-Weber '08.

**Proposition.** *Modulo rescalings and biholomorphisms, there is exactly one conformally Kähler, Einstein metric  $g$  on  $M = \mathbb{C}P_2 \# \overline{\mathbb{C}P_2}$ . This metric coincides with the Page metric.*

**Proposition.** *Modulo rescalings and biholomorphisms, there is exactly one conformally Kähler, Einstein metric  $g$  on  $M = \mathbb{C}\mathbb{P}_2 \# \overline{\mathbb{C}\mathbb{P}_2}$ . This metric coincides with the Page metric.*

**Proposition.** *Modulo rescalings and biholomorphisms, there is exactly one conformally Kähler, Einstein metric  $g$  on  $M = \mathbb{C}\mathbb{P}_2 \# 2\overline{\mathbb{C}\mathbb{P}_2}$ . This metric coincides with the C-L-W metric.*

**Proposition.** *Modulo rescalings and biholomorphisms, there is exactly one conformally Kähler, Einstein metric  $g$  on  $M = \mathbb{C}P_2 \# \overline{\mathbb{C}P_2}$ . This metric coincides with the Page metric.*

**Proposition.** *Modulo rescalings and biholomorphisms, there is exactly one conformally Kähler, Einstein metric  $g$  on  $M = \mathbb{C}P_2 \# 2\overline{\mathbb{C}P_2}$ . This metric coincides with the C-L-W metric.*

**Proposition.** *Modulo rescalings and biholomorphisms, there is only one conformally Kähler, Einstein metric  $g$  on  $M = \mathbb{C}P_2 \# 3\overline{\mathbb{C}P_2}$ . This metric is actually *Kähler-Einstein*, and is exactly the metric discovered by Siu.*

In particular, our existence results prove...

**Theorem.** Suppose that  $M$  is a smooth compact oriented 4-manifold which admits a complex structure  $J$ . Then  $M$  also admits an (unrelated) Einstein metric  $g$  with  $\lambda > 0$

$$\iff M \approx \begin{cases} \mathbb{C}P_2 \#^k \overline{\mathbb{C}P_2}, & 0 \leq k \leq 8, \\ \text{or} \\ S^2 \times S^2 \end{cases}$$

**Theorem.** Suppose that  $M$  is a smooth compact oriented 4-manifold which admits a complex structure  $J$ . Then  $M$  also admits an (unrelated) Einstein metric  $g$  with  $\lambda > 0$

$$\iff M \approx \begin{cases} \mathbb{C}P_2 \# k \overline{\mathbb{C}P_2}, & 0 \leq k \leq 8, \\ \text{or} \\ S^2 \times S^2 \end{cases}$$

But combining this with results in symplectic geometry, we also obtain a symplectic analog...

**Theorem.** *Suppose that  $M$  is a smooth compact oriented 4-manifold which admits a symplectic form  $\omega$ .*

**Theorem.** *Suppose that  $M$  is a smooth compact oriented 4-manifold which admits a symplectic form  $\omega$ .*

$$\omega \in \Gamma(\wedge^2), \quad d\omega = 0, \quad \lrcorner\omega : TM \xrightarrow{\cong} T^*M.$$

**Theorem.** *Suppose that  $M$  is a smooth compact oriented 4-manifold which admits a symplectic form  $\omega$ .*

$$\omega \in \Gamma(\wedge^2), \quad d\omega = 0, \quad \omega \wedge \omega > 0.$$

**Theorem.** *Suppose that  $M$  is a smooth compact oriented 4-manifold which admits a symplectic form  $\omega$ .*

**Theorem.** *Suppose that  $M$  is a smooth compact oriented 4-manifold which admits a symplectic form  $\omega$ . Then  $M$  also admits an (unrelated) Einstein metric  $g$  with  $\lambda > 0$*

**Theorem.** *Suppose that  $M$  is a smooth compact oriented 4-manifold which admits a symplectic form  $\omega$ . Then  $M$  also admits an (unrelated) Einstein metric  $g$  with  $\lambda > 0$*

$$\iff M \approx \begin{cases} \mathbb{C}P_2 \#^k \overline{\mathbb{C}P_2}, & 0 \leq k \leq 8, \\ \text{or} \\ S^2 \times S^2 \end{cases}$$

**Theorem.** *Suppose that  $M$  is a smooth compact oriented 4-manifold which admits a symplectic form  $\omega$ . Then  $M$  also admits an (unrelated) Einstein metric  $g$  with  $\lambda > 0$*

$$\iff M \approx \begin{cases} \mathbb{C}P_2 \#^k \overline{\mathbb{C}P_2}, & 0 \leq k \leq 8, \\ \text{or} \\ S^2 \times S^2 \end{cases}$$

Similar ideas also yield analogous results concerning Einstein metrics with  $\lambda \geq 0$ :

**Theorem.** *Suppose that  $M$  is a smooth compact oriented 4-manifold which admits an integrable complex structure  $J$ .*

**Theorem.** *Suppose that  $M$  is a smooth compact oriented 4-manifold which admits an integrable complex structure  $J$ . Then  $M$  also admits an Einstein metric  $g$  with  $\lambda \geq 0$  if and only if*

**Theorem.** *Suppose that  $M$  is a smooth compact oriented 4-manifold which admits an integrable complex structure  $J$ . Then  $M$  also admits an Einstein metric  $g$  with  $\lambda \geq 0$  if and only if*

$$M \approx \left\{ \begin{array}{l} \mathbb{C}P_2 \# k \overline{\mathbb{C}P_2}, \end{array} \right.$$

**Theorem.** *Suppose that  $M$  is a smooth compact oriented 4-manifold which admits an integrable complex structure  $J$ . Then  $M$  also admits an Einstein metric  $g$  with  $\lambda \geq 0$  if and only if*

$$M \approx \left\{ \begin{array}{l} \mathbb{C}P_2 \# k \overline{\mathbb{C}P_2}, \quad 0 \leq k \leq 8, \end{array} \right.$$

**Theorem.** *Suppose that  $M$  is a smooth compact oriented 4-manifold which admits an integrable complex structure  $J$ . Then  $M$  also admits an Einstein metric  $g$  with  $\lambda \geq 0$  if and only if*

$$M \approx \left\{ \begin{array}{l} \mathbb{C}P_2 \# k \overline{\mathbb{C}P_2}, \quad 0 \leq k \leq 8, \\ S^2 \times S^2, \end{array} \right.$$

**Theorem.** *Suppose that  $M$  is a smooth compact oriented 4-manifold which admits an integrable complex structure  $J$ . Then  $M$  also admits an Einstein metric  $g$  with  $\lambda \geq 0$  if and only if*

$$M \approx \left\{ \begin{array}{l} \mathbb{C}P_2 \# k \overline{\mathbb{C}P_2}, \quad 0 \leq k \leq 8, \\ S^2 \times S^2, \\ K3, \end{array} \right.$$

**Theorem.** *Suppose that  $M$  is a smooth compact oriented 4-manifold which admits an integrable complex structure  $J$ . Then  $M$  also admits an Einstein metric  $g$  with  $\lambda \geq 0$  if and only if*

$$M \approx \begin{cases} \mathbb{C}P_2 \# k \overline{\mathbb{C}P_2}, & 0 \leq k \leq 8, \\ S^2 \times S^2, \\ K3, \\ K3/\mathbb{Z}_2, \end{cases}$$

**Theorem.** *Suppose that  $M$  is a smooth compact oriented 4-manifold which admits an integrable complex structure  $J$ . Then  $M$  also admits an Einstein metric  $g$  with  $\lambda \geq 0$  if and only if*

$$M \approx \begin{cases} \mathbb{C}P_2 \# k \overline{\mathbb{C}P_2}, & 0 \leq k \leq 8, \\ S^2 \times S^2, \\ K3, \\ K3/\mathbb{Z}_2, \\ T^4, \end{cases}$$

**Theorem.** *Suppose that  $M$  is a smooth compact oriented 4-manifold which admits an integrable complex structure  $J$ . Then  $M$  also admits an Einstein metric  $g$  with  $\lambda \geq 0$  if and only if*

$$M \approx \left\{ \begin{array}{l} \mathbb{C}P_2 \# k \overline{\mathbb{C}P}_2, \quad 0 \leq k \leq 8, \\ S^2 \times S^2, \\ K3, \\ K3/\mathbb{Z}_2, \\ T^4, \\ T^4/\mathbb{Z}_2, T^4/\mathbb{Z}_3, T^4/\mathbb{Z}_4, T^4/\mathbb{Z}_6, \end{array} \right.$$

**Theorem.** *Suppose that  $M$  is a smooth compact oriented 4-manifold which admits an integrable complex structure  $J$ . Then  $M$  also admits an Einstein metric  $g$  with  $\lambda \geq 0$  if and only if*

$$M \approx \left\{ \begin{array}{l} \mathbb{C}P_2 \# k \overline{\mathbb{C}P}_2, \quad 0 \leq k \leq 8, \\ S^2 \times S^2, \\ K3, \\ K3/\mathbb{Z}_2, \\ T^4, \\ T^4/\mathbb{Z}_2, T^4/\mathbb{Z}_3, T^4/\mathbb{Z}_4, T^4/\mathbb{Z}_6, \\ T^4/(\mathbb{Z}_2 \oplus \mathbb{Z}_2), T^4/(\mathbb{Z}_3 \oplus \mathbb{Z}_3), \text{ or } T^4/(\mathbb{Z}_2 \oplus \mathbb{Z}_4). \end{array} \right.$$

**Theorem.** Suppose that  $M$  is a smooth compact oriented 4-manifold which admits an integrable complex structure  $J$ . Then  $M$  also admits an Einstein metric  $g$  with  $\lambda \geq 0$  if and only if

$$M \approx \left\{ \begin{array}{l} \mathbb{C}P_2 \# k \overline{\mathbb{C}P}_2, \quad 0 \leq k \leq 8, \\ S^2 \times S^2, \\ K3, \\ K3/\mathbb{Z}_2, \\ T^4, \\ T^4/\mathbb{Z}_2, T^4/\mathbb{Z}_3, T^4/\mathbb{Z}_4, T^4/\mathbb{Z}_6, \\ T^4/(\mathbb{Z}_2 \oplus \mathbb{Z}_2), T^4/(\mathbb{Z}_3 \oplus \mathbb{Z}_3), \text{ or } T^4/(\mathbb{Z}_2 \oplus \mathbb{Z}_4). \end{array} \right.$$

Del Pezzo surfaces,

K3 surface, Enriques surface,

Abelian surface, Hyper-elliptic surfaces.

**Theorem.** *Suppose that  $M$  is a smooth compact oriented 4-manifold which admits an integrable complex structure  $J$ . Then  $M$  also admits an Einstein metric  $g$  with  $\lambda \geq 0$  if and only if*

$$M \approx \left\{ \begin{array}{l} \mathbb{C}P_2 \# k \overline{\mathbb{C}P}_2, \quad 0 \leq k \leq 8, \\ S^2 \times S^2, \\ K3, \\ K3/\mathbb{Z}_2, \\ T^4, \\ T^4/\mathbb{Z}_2, T^4/\mathbb{Z}_3, T^4/\mathbb{Z}_4, T^4/\mathbb{Z}_6, \\ T^4/(\mathbb{Z}_2 \oplus \mathbb{Z}_2), T^4/(\mathbb{Z}_3 \oplus \mathbb{Z}_3), \text{ or } T^4/(\mathbb{Z}_2 \oplus \mathbb{Z}_4). \end{array} \right.$$

**Theorem.** Suppose that  $M$  is a smooth compact oriented 4-manifold which admits a symplectic form  $\omega$ . Then  $M$  also admits an Einstein metric  $g$  with  $\lambda \geq 0$  if and only if

$$M \stackrel{\text{diff}}{\approx} \left\{ \begin{array}{l} \mathbb{C}\mathbb{P}_2 \# k \overline{\mathbb{C}\mathbb{P}_2}, \quad 0 \leq k \leq 8, \\ S^2 \times S^2, \\ K3, \\ K3/\mathbb{Z}_2, \\ T^4, \\ T^4/\mathbb{Z}_2, T^4/\mathbb{Z}_3, T^4/\mathbb{Z}_4, T^4/\mathbb{Z}_6, \\ T^4/(\mathbb{Z}_2 \oplus \mathbb{Z}_2), T^4/(\mathbb{Z}_3 \oplus \mathbb{Z}_3), \text{ or } T^4/(\mathbb{Z}_2 \oplus \mathbb{Z}_4). \end{array} \right.$$

By contrast, the  $\lambda < 0$  case is only partly settled:

**Theorem.** *Let  $M$  be the 4-manifold underlying a compact complex surface. Suppose moreover that  $M$  carries an Einstein metric  $g$ .*

**Theorem.** *Let  $M$  be the 4-manifold underlying a compact complex surface. Suppose moreover that  $M$  carries an Einstein metric  $g$ . Then either  $M$  appears on list for  $\lambda \geq 0$ ,*

**Theorem.** *Let  $M$  be the 4-manifold underlying a compact complex surface. Suppose moreover that  $M$  carries an Einstein metric  $g$ . Then either  $M$  appears on list for  $\lambda \geq 0$ , or else*

- *$M$  is a surface of general type;*

**Theorem.** *Let  $M$  be the 4-manifold underlying a compact complex surface. Suppose moreover that  $M$  carries an Einstein metric  $g$ . Then either  $M$  appears on list for  $\lambda \geq 0$ , or else*

- *$M$  is a surface of general type; and*
- *$M$  is not too non-minimal*

**Theorem.** *Let  $M$  be the 4-manifold underlying a compact complex surface. Suppose moreover that  $M$  carries an Einstein metric  $g$ . Then either  $M$  appears on list for  $\lambda \geq 0$ , or else*

- *$M$  is a surface of general type; and*
- *$M$  is not too non-minimal*

*in the sense that it is obtained from its minimal model  $X$  by blowing up at  $k < c_1^2(X)/3$  points.*

**Theorem.** *Let  $M$  be the 4-manifold underlying a compact complex surface. Suppose moreover that  $M$  carries an Einstein metric  $g$ . Then either  $M$  appears on list for  $\lambda \geq 0$ , or else*

- *$M$  is a surface of general type; and*
- *$M$  is not too non-minimal*

*in the sense that it is obtained from its minimal model  $X$  by blowing up at  $k < c_1^2(X)/3$  points.*

In particular,  $M$  carries Kähler metrics, and therefore admits symplectic structures.

**Theorem.** *Let  $M$  be the 4-manifold underlying a compact complex surface. Suppose moreover that  $M$  carries an Einstein metric  $g$ . Then either  $M$  appears on list for  $\lambda \geq 0$ , or else*

- *$M$  is a surface of general type; and*
- *$M$  is not too non-minimal*

*in the sense that it is obtained from its minimal model  $X$  by blowing up at  $k < c_1^2(X)/3$  points.*

Same conclusion holds in symplectic case.

**Theorem.** *Let  $M$  be the 4-manifold underlying a compact complex surface. Suppose moreover that  $M$  carries an Einstein metric  $g$ . Then either  $M$  appears on list for  $\lambda \geq 0$ , or else*

- *$M$  is a surface of general type; and*
- *$M$  is not too non-minimal*

*in the sense that it is obtained from its minimal model  $X$  by blowing up at  $k < c_1^2(X)/3$  points.*

Same conclusion holds in symplectic case.

General type: Minimal model  $X$  satisfies

$$c_1^2(X) > 0$$

$$c_1(X) \cdot [\omega_X] < 0.$$

Two outstanding problems in  $\lambda < 0$  case:

Two outstanding problems in  $\lambda < 0$  case:

**Main Question.** *Are there any non-minimal complex surfaces  $M$  of general type which actually admit Einstein metrics?*

Two outstanding problems in  $\lambda < 0$  case:

**Main Question.** *Are there any non-minimal complex surfaces  $M$  of general type which actually admit Einstein metrics?*

**Main Question.** *Are there any non-complex symplectic 4-manifolds  $M$  of general type which actually admit Einstein metrics?*

Two outstanding problems in  $\lambda < 0$  case:

**Main Question.** *Are there any non-minimal complex surfaces  $M$  of general type which actually admit Einstein metrics?*

**Main Question.** *Are there any non-complex symplectic 4-manifolds  $M$  of general type which actually admit Einstein metrics?*

If so, quite different from Kähler-Einstein metrics!

# For further reading:

## References

- [1] X. X. CHEN, C. LEBRUN, AND B. WEBER, *On conformally Kähler, Einstein manifolds*, J. Amer. Math. Soc., 21 (2008), pp. 1137–1168.
- [2] M. ISHIDA AND C. LEBRUN, *Spin manifolds, Einstein metrics, and differential topology*, Math. Res. Lett., 9 (2002), pp. 229–240.
- [3] —, *Curvature, connected sums, and Seiberg-Witten theory*, Comm. Anal. Geom., 11 (2003), pp. 809–836.
- [4] C. LEBRUN, *Einstein metrics and Mostow rigidity*, Math. Res. Lett., 2 (1995), pp. 1–8.
- [5] —, *Four-manifolds without Einstein metrics*, Math. Res. Lett., 3 (1996), pp. 133–147.
- [6] —, *Kodaira dimension and the Yamabe problem*, Comm. Anal. Geom., 7 (1999), pp. 133–156.
- [7] —, *Ricci curvature, minimal volumes, and Seiberg-Witten theory*, Inv. Math., 145 (2001), pp. 279–316.
- [8] —, *Einstein metrics, four-manifolds, and differential topology*, in Surveys in differential geometry, Vol. VIII (Boston, MA, 2002), Surv. Differ. Geom., VIII, Int. Press, Somerville, MA, 2003, pp. 235–255.
- [9] —, *Four-manifolds, curvature bounds, and convex geometry*, in Riemannian topology and geometric structures on manifolds, vol. 271 of Progr. Math., Birkhäuser Boston, Boston, MA, 2009, pp. 119–152.
- [10] —, *Einstein metrics, complex surfaces, and symplectic 4-manifolds*, Math. Proc. Cambridge Philos. Soc., 147 (2009), pp. 1–8.
- [11] —, *On Einstein, Hermitian 4-manifolds*, J. Differential Geom., 90 (2012), pp. 277–302.
- [12] —, *Einstein manifolds and extremal Kähler metrics*, J. Reine Angew. Math., 678 (2013), pp. 69–94.
- [13] —, *Twistors, self-duality, and  $spin^c$  structures*, SIGMA: Symmetry Integrability Geom. Methods Appl., 17 (2021), Paper No. 102, 11 pp.
- [14] —, *The scalar curvature of 4-manifolds*, in Perspectives in Scalar Curvature. Gromov and Lawson, editors. Vol. 1, World Sci. Publ., Hackensack, NJ, 2023, pp. 643–707.

# Additional References:

## References

- [1] T. AUBIN, *Équations différentielles non linéaires et problème de Yamabe concernant la courbure scalaire*, J. Math. Pures Appl. (9), 55 (1976), pp. 269–296.
- [2] W. BARTH, C. PETERS, AND A. VAN DE VEN, *Compact Complex Surfaces*, vol. 4 of Ergebnisse der Mathematik und ihrer Grenzgebiete (3), Springer-Verlag, Berlin, 1984.
- [3] S. BAUER, *A stable cohomotopy refinement of Seiberg-Witten invariants. II*, Invent. Math., 155 (2004), pp. 21–40.
- [4] S. BAUER AND M. FURUTA, *A stable cohomotopy refinement of Seiberg-Witten invariants. I*, Invent. Math., 155 (2004), pp. 1–19.
- [5] A. L. BESSE, *Einstein Manifolds*, vol. 10 of Ergebnisse der Mathematik und ihrer Grenzgebiete (3), Springer-Verlag, Berlin, 1987.
- [6] S. K. DONALDSON, *An application of gauge theory to four-dimensional topology*, J. Differential Geom., 18 (1983), pp. 279–315.
- [7] S. K. DONALDSON AND P. B. KRONHEIMER, *The Geometry of Four-Manifolds*, Oxford University Press, Oxford, 1990.
- [8] M. FREDMAN, *On the topology of 4-manifolds*, J. Differential Geom., 17 (1982), pp. 357–454.
- [9] R. FRIEDMAN AND J. MORGAN, *Algebraic surfaces and Seiberg-Witten invariants*, J. Alg. Geom., 6 (1997), pp. 445–479.
- [10] M. GROMOV AND H. B. LAWSON, *The classification of simply connected manifolds of positive scalar curvature*, Ann. Math., 111 (1980), pp. 423–434.
- [11] N. J. HITCHIN, *Harmonic spinors*, Adv. Math., 14 (1974), pp. 1–55.
- [12] P. B. KRONHEIMER AND T. MROWKA, *The genus of embedded surfaces in the complex projective plane*, Math. Res. Lett., 1 (1994), pp. 797–808.
- [13] H. B. LAWSON AND M. MICHELSON, *Spin Geometry*, Princeton University Press, 1989.
- [14] D. MCDUFF, *The structure of rational and ruled symplectic 4-manifolds*, J. Amer. Math. Soc., 3 (1990), pp. 679–712.
- [15] J. MORGAN, *The Seiberg-Witten Equations and Applications to the Topology of Smooth Four-Manifolds*, vol. 44 of Mathematical Notes, Princeton University Press, 1996.
- [16] Y. ODAKA, C. SPOTTI, AND S. SUN, *Compact moduli spaces of del Pezzo surfaces and Kähler-Einstein metrics*, J. Differential Geom., 102 (2016), pp. 127–172.
- [17] H. OHTA AND K. ONO, *Notes on symplectic 4-manifolds with  $b_2^+ = 1$ . II*, Internat. J. Math., 7 (1996), pp. 755–770.
- [18] J. PETEAN, *The Yamabe invariant of simply connected manifolds*, J. Reine Angew. Math., 523 (2000), pp. 225–231.
- [19] R. SCHOEN, *Variational theory for the total scalar curvature functional for Riemannian metrics and related topics*, Lec. Notes Math., 1365 (1987), pp. 120–154.
- [20] S. STOLZ, *Simply connected manifolds of positive scalar curvature*, Ann. Math., (2) 136 (1992), pp. 511–540.
- [21] C. H. TAUBES, *The Seiberg-Witten invariants and symplectic forms*, Math. Res. Lett., 1 (1994), pp. 809–822.
- [22] G. TIAN AND S.-T. YAU, *Kähler-Einstein metrics on complex surfaces with  $C_1 > 0$* , Comm. Math. Phys., 112 (1987), pp. 175–203.
- [23] E. WITTEN, *Monopoles and four-manifolds*, Math. Res. Lett., 1 (1994), pp. 809–822.
- [24] S. T. YAU, *Calabi’s conjecture and some new results in algebraic geometry*, Proc. Nat. Acad. Sci. U.S.A., 74 (1977), pp. 1798–1799.

*End of Lecture Series*