

# Solutions to MAT 342 Midterm

## Applied Complex Analysis

March 28, 2019

Name: \_\_\_\_\_

Student ID: \_\_\_\_\_

### Instructions:

There are 6 problems on 6 pages (plus this cover sheet) in this exam. Make sure that you have them all.

Answer all questions below. You may use the backs of pages, but in this case indicate where your work for each problem is located. You must show all of your work and provide **complete justifications** for all of your claims. Insufficient justifications will not receive full credit.

Leave all answers in exact form (that is, do not approximate  $\pi$ , square roots, and so on.)

You may **not** use books, notes, calculators, cell phones or other electronic devices.

You have 1 hour and 10 minutes to complete this exam.

Problem	1	2	3	4	5	6	Total
Points	10	10	10	10	10	10	60
Score							

[10 pts] **Problem 1.**

- (i) When is a function called entire?

**Solution:**

A function  $f$  is entire if it is analytic in the entire complex plane.

Alternatively:

A function  $f$  is entire if  $f'(z)$  exists for all  $z \in \mathbb{C}$ .

- (ii) What is the largest domain in which the function

$$f(z) = \frac{\text{Log}(-iz)}{z^2 + i}$$

is analytic and why is it analytic there? What are the singular points of  $f$ ? Explain carefully.

**Solution:**

The function  $z^2 + i$  is analytic in  $\mathbb{C}$  since it is a polynomial. The function  $\text{Log}(-iz)$  is analytic everywhere, except at the points  $z$  for which  $-iz$  lies in the negative real axis or  $-iz = 0$ , since  $\text{Log}$  is not analytic there. By writing  $z = x + iy$ , we see that  $-iz = -ix + y$  and  $-iz$  lies in the negative real axis if  $x = 0$  and  $y < 0$ . Therefore,  $\text{Log}(-iz)$  is analytic everywhere except at  $\{(x, y) : x = 0, y \leq 0\}$ .

Since  $f$  is the quotient of two analytic functions,  $f$  is analytic in the common domain of  $\text{Log}(-iz)$  and  $z^2 + i$  except at the points where the denominator  $z^2 + i$  is equal to 0. If  $z^2 + i = 0$  then  $z^2 = -i = e^{-i\pi/2}$ , so  $z = \pm e^{-i\pi/4}$ . Summarizing,  $f$  is analytic everywhere in  $\mathbb{C}$ , except at  $\{(x, y) : x = 0, y \leq 0\}$  and at  $\{e^{-i\pi/4}, -e^{-i\pi/4}\}$ .

The singular points of  $f$  are the points  $\pm e^{-i\pi/4}$  because  $f$  is not analytic at these points but it is analytic in a punctured neighborhood of each of these points.

[10 pts] **Problem 2.**

- (i) What does it mean for a function  $f: S \rightarrow \mathbb{C}$  to be differentiable at a point  $z_0 \in S$ , where  $S$  contains a neighborhood of  $z_0$ ?

**Solution:**

$f$  is differentiable at  $z_0$  if the limit  $\lim_{z \rightarrow z_0} \frac{f(z) - f(z_0)}{z - z_0}$  exists.

Alternatively:

$f$  is differentiable at  $z_0$  if the limit  $\lim_{h \rightarrow 0} \frac{f(z_0 + h) - f(z_0)}{h}$  exists.

- (ii) Examine whether the function  $f(z) = \bar{z} \operatorname{Im} z$  is differentiable at any point  $z$ , in which case, compute  $f'(z)$ . Is  $f$  analytic at any point of  $\mathbb{C}$ ?

**Solution:**

If  $z = x + iy$ , we have  $f(z) = (x - iy)y = xy - iy^2 = u(x, y) + iv(x, y)$ , where  $u(x, y) = xy$  and  $v(x, y) = -y^2$ . If  $f$  is differentiable at a point  $(x, y)$  then the Cauchy-Riemann equations have to be satisfied. So we must have  $u_x = v_y$  and  $u_y = -v_x$ . This implies that  $y = -2y$  and  $x = 0$ , so  $(x, y) = (0, 0)$ . Therefore the point  $(0, 0)$  is the only point where the function  $f$  can be differentiable.

The Cauchy-Riemann equations are satisfied at the point  $z = 0$  and the partial derivatives of  $u, v$  are continuous everywhere. Therefore,  $f$  is differentiable at 0 with  $f'(0) = u_x(0) + iv_x(0) = 0$ .

Since  $f$  is not differentiable at any neighborhood of 0 but only at 0, we conclude that  $f$  is not analytic at 0. Moreover,  $f$  is not analytic at any other point since  $f'$  does not exist at any point other than 0.

[10 pts] **Problem 3.** Consider the domain  $D$  consisting of the complex plane with the positive imaginary axis and 0 removed.

- (i) Describe the branch of the power function  $f(z) = z^i$  defined in the domain  $D$  for which  $f(1) = e^{-2\pi}$ .

**Solution:**

We have  $f(z) = z^i = e^{i \log z}$ , where  $\log z$  is the branch of the logarithm defined by

$$\log z = \ln r + i\theta, \quad z = re^{i\theta}, \quad r > 0, \quad \pi/2 < \theta < 5\pi/2.$$

We write  $1 = e^{i0} = e^{2\pi i}$ . Since  $\pi/2 < 2\pi < 5\pi/2$ , we have  $\log 1 = \ln 1 + 2\pi i = 2\pi i$ . Hence, for the chosen branch we have indeed that

$$f(1) = e^{i \cdot 2\pi i} = e^{-2\pi}.$$

- (ii) Calculate  $f(1 + i)$ .

**Solution:**

We have

$$1 + i = \sqrt{2}e^{i\pi/4} = \sqrt{2}e^{i(\pi/4+2\pi)} = \sqrt{2}e^{i9\pi/4}.$$

Since  $\pi/2 < 9\pi/4 < 5\pi/2$ , we have

$$\log(1 + i) = \ln(\sqrt{2}) + i9\pi/4,$$

so

$$f(1 + i) = e^{i(\ln \sqrt{2} + i9\pi/4)} = e^{-9\pi/4}(\cos(\ln \sqrt{2}) + i \sin(\ln \sqrt{2})).$$

[10 pts] **Problem 4.**

- (i) State the Cauchy-Goursat theorem.

**Solution:**

If a function  $f$  is analytic in the interior of a simple closed contour  $C$  and also on  $C$ , then

$$\int_C f(z) dz = 0.$$

- (ii) Calculate the contour integral

$$\int_C (e^{-\sin z} + \bar{z} \operatorname{Re} z) dz,$$

where  $C$  is the contour consisting of the curve  $z(t) = t^2 + it^3$ ,  $0 \leq t \leq 1$ , followed by the line segment from  $1 + i$  to  $0$ .

**Solution:**

The given contour  $C$  is a simple closed contour. Moreover, the function  $e^{-\sin z}$  is entire, since it is the composition of the entire functions  $e^z$  and  $-\sin z$ . Therefore, by the Cauchy-Goursat theorem we have

$$\int_C e^{-\sin z} dz = 0.$$

It follows that

$$\int_C (e^{-\sin z} + \bar{z} \operatorname{Re} z) dz = \int_C e^{-\sin z} dz + \int_C \bar{z} \operatorname{Re} z dz = \int_C \bar{z} \operatorname{Re} z dz.$$

We now have to compute the last integral. We write  $C = C_1 + C_2$ , where  $C_1$  is the contour represented by  $z(t) = t^2 + it^3$ ,  $0 \leq t \leq 1$ , and  $C_2$  is the line segment from  $1 + i$  to  $0$ . We have

$$\begin{aligned} \int_{C_1} \bar{z} \operatorname{Re} z dz &= \int_{C_1} (x - iy) x dz = \int_{C_1} (x^2 - iyx) dz = \int_0^1 ((t^2)^2 - it^2 t^3)(2t + 3it^2) dt \\ &= \int_0^1 (2t^5 + it^6 + 3t^7) dt = (t^6/3 + it^7/7 + 3t^8/8) \Big|_0^1 = 17/24 + i/7. \end{aligned}$$

Now, we parametrize  $C_2$  by  $z(t) = (1-t)(1+i)$ ,  $0 \leq t \leq 1$ . Note that  $z(0) = 1+i$ ,  $z(1) = 0$ , and  $z'(t) = -(1+i)$ . We have

$$\begin{aligned} \int_{C_2} \bar{z} \operatorname{Re} z dz &= \int_0^1 ((1-t)^2 - i(1-t)^2)(-(1+i)) dt = -(1+i)(1-i) \int_0^1 (1-t)^2 dt \\ &= 2(1-t)^3/3 \Big|_0^1 = -2/3. \end{aligned}$$

Summarizing, we have

$$\int_C \bar{z} \operatorname{Re} z dz = \int_{C_1} \bar{z} \operatorname{Re} z dz + \int_{C_2} \bar{z} \operatorname{Re} z dz = 17/24 + i/7 - 2/3 = 1/24 + i/7.$$

[10 pts] **Problem 5.** Consider the set  $S = \{z : 0 \leq \operatorname{Re} z < 1\}$ .

- (i) Is the set  $S$  open, closed, or neither? Explain carefully.

**Solution:**

We write  $S = \{(x, y) : 0 \leq x < 1\}$ . The boundary of the set  $S$  consists of the vertical lines  $x = 0$  and  $x = 1$ . We note that the line  $x = 0$  is contained in  $S$ , so the set  $S$  cannot be open since it contains some boundary points. On the other hand, the line  $x = 1$  is not contained in  $S$ , so the set  $S$  is not closed because it does not contain its entire boundary.

- (ii) Find the image of the set  $S$  under the function  $f(z) = e^z$ . As part of your answer, include a sketch of  $f(S)$ , using solid lines to indicate boundaries which are included and dashed lines to indicate boundaries not included. Shade the interior of  $f(S)$  (if there is one).

**Solution:**

For  $z = x + iy$  we have  $e^z = e^x \cdot e^{iy}$ . If  $z$  lies on a vertical line  $x = c$ , then the image of that line is all points of the form  $e^c e^{iy}$ , where  $y$  ranges over all real numbers. The points of the form  $e^c e^{iy}$  represent circles of radius  $e^c$  centered at the origin. Therefore, the image under  $e^z$  of a vertical line  $x = c$  is a circle of radius  $e^c$  about the origin.

The set  $S$  consists of vertical lines  $x = c$ , where  $0 \leq c < 1$ . Therefore, the image of  $S$  under  $e^z$  is a collection of circles about the origin with radii  $1 = e^0 \leq r < e^1$ . In other words, the image of  $S$  is an annulus centered at the origin with inner radius 1 and outer radius  $e$ , including the boundary circle of radius 1 but not the boundary circle of radius  $e$ .

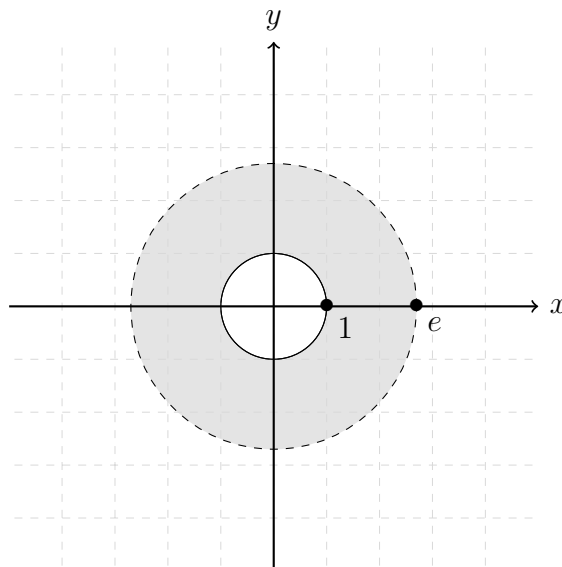

[10 pts] **Problem 6.**

- (i) Is the function  $u(x, y) = x^2e^{y^2}$  the real part of an analytic function? Explain carefully.

**Solution:**

If  $u$  is the real part of an analytic function then it must be harmonic, so it has to satisfy Laplace's equation:  $u_{xx} + u_{yy} = 0$ . Note that  $u_x = 2xe^{y^2}$ ,  $u_{xx} = 2e^{y^2}$ ,  $u_y = x^2e^{y^2} \cdot 2y$ ,  $u_{yy} = x^2e^{y^2}(2y)^2 + 2x^2e^{y^2}$ . Therefore,

$$u_{xx} + u_{yy} = 2e^{y^2} + x^2e^{y^2}(2y)^2 + 2x^2e^{y^2} = 2e^{y^2}(1 + 2x^2y^2 + x^2).$$

The function on the right hand side is always positive, therefore Laplace's equation is not satisfied at any point  $(x, y)$ , and the function  $u$  is not harmonic.

- (ii) Suppose that  $g$  is an entire function such that  $g(z) = e^z$  for all points  $z$  lying in the unit disk  $|z| < 1$ . What can you say about the function  $g$ ?

**Solution:**

Consider the function  $f(z) = e^z$ . The functions  $f$  and  $g$  are both entire and they are equal to each other in the segment  $[-1/2, 1/2] \times \{0\}$  (in fact they are equal to each other in any segment that is contained in the unit disk  $|z| < 1$ ). By the coincidence principle we conclude that  $f(z) = g(z)$  for all  $z \in \mathbb{C}$ , so  $g(z) = e^z$  for all  $z \in \mathbb{C}$ .