

# Pruning fronts and the formation of horseshoes

by

André de Carvalho

Department of Mathematics  
University of California  
Berkeley, CA 94720-3840  
E-mail: andre@@math.berkeley.edu

## Abstract

Let  $f : \pi \rightarrow \pi$  be a homeomorphism of the plane  $\pi$ . We define open sets  $P$ , called *pruning fronts* after the work of Cvitanović [C], for which it is possible to construct an isotopy  $H : \pi \times [0, 1] \rightarrow \pi$  with open support contained in  $\bigcup_{n \in \mathbb{Z}} f^n(P)$  such that  $H(\cdot, 0) = f(\cdot)$  and  $H(\cdot, 1) = f_P(\cdot)$ , where  $f_P$  is a homeomorphism under which every point of  $P$  is wandering. Applying this construction with  $f$  being Smale's horseshoe, it is possible to obtain an uncountable family of homeomorphisms, depending on infinitely many parameters, going from trivial to chaotic dynamic behaviour. This family is a 2-dimensional analog of a 1-dimensional universal family.

## 0 Introduction

One of the main concerns in the study of dynamical systems is to understand how a family of maps passes from simple to complicated dynamic behaviour as we vary parameters. When the dynamical systems under consideration are 1-dimensional, the kneading theory of Milnor and Thurston provides a full topological understanding of the transition from simple to chaotic behaviour. In dimension 2, no such theory exists. In fact, it is not clear what restrictions should be imposed on the families under consideration in order that understanding them is not too hopeless a task.

Families like the Hénon and the Lozi ones are interesting examples but they lack a defining topological characteristic analogous, for example, to saying that a 1-dimensional map is *unimodal* (i.e., is piecewise monotone with exactly one turning point.)

In this work, we present a method of isotoping away dynamics from a homeomorphism of the plane in a controlled fashion. More precisely, if  $f : \pi \rightarrow \pi$  is a homeomorphism of the plane  $\pi$ , we define open sets  $P$  for which there exists an isotopy  $H : \pi \times [0, 1] \rightarrow \pi$  with (open) support

contained in  $\bigcup_{n \in \mathbb{Z}} f^n(P)$ , such that  $H(\cdot, 0) = f$  and  $H(\cdot, 1) = f_P$ , where  $f_P$  is a homeomorphism under which every point of  $P$  is wandering. Using this construction, with  $f$  being Smale's horseshoe, for example, it is possible to produce an uncountable family of homeomorphisms of the plane, depending on infinitely many parameters, going from trivial dynamics (say, only two nonwandering points, one attracting and one repelling fixed points) to a full horseshoe.

We call the sets  $P$  mentioned above *pruning fronts*, after the work of P. Cvitanović [C]. In [C] they propose sets of symbol space for Smale's horseshoe which get "pruned away" as we vary parameters in a family like the Hénon one. Here we give a precise definition of pruning fronts and construct the isotopies which "prune away" the dynamics in  $P$ .

In forthcoming papers we intend to do two things. First, for each map  $f_P$ , where  $P$  is a pruning front as defined herein, there exists a collapsing procedure which produces a "tight" map  $\varphi_P$  isotopic to  $f_P$  and with essentially the same dynamics. More precisely, there exists an  $f_P$ -invariant upper semi-continuous decomposition  $G_P$  of the sphere  $S^2$  (we can extend  $f$  to  $S^2$  setting  $f(\infty) = \infty$ ), such that, for every element  $g$  of  $G_P$ ,  $g$  contains at least one element of the nonwandering set of  $f_P$  and  $h(f_P; g) = 0$ , where  $h(f_P; g)$  is the topological entropy of  $f_P$  in  $g$  as defined by Bowen.  $f_P$  then projects to a homeomorphism  $\varphi_P : K_P \rightarrow K_P$  of the *cactoid*  $K_P = S^2/G_P$ , such that no point of  $K_P$  is wandering under  $\varphi_P$  and  $h(f_P) = h(\varphi_P)$ . Second, we intend to show that the family  $\varphi_P$  contains the Thurston minimal representatives in the isotopy classes of  $f$  relative to periodic orbit collections of  $f$ . In other words, we would like to show that given a periodic orbit collection  $\mathcal{O}$  of periodic orbits of  $f$ , there exists a pruning front  $P = P(\mathcal{O})$ , such that  $\varphi_P$  is the Thurston minimal representative in the isotopy class of  $f$  rel  $\mathcal{O}$ . This last statement should have an algorithmic proof, providing another algorithmic proof of Thurston's classification theorem for homeomorphisms of surfaces.

The techniques used in the present work are those of point set topology of the plane. In Section 1 we state without proof the main background results we will need, the most important of which being the Jordan Curve Theorem (Theorem 1.1) and Whyburn's Separation Theorem (Theorem 1.3). In Section 2 we develop the plane topology tools we will use in the remainder of the paper. In Section 3 we introduce the concept of  $(c, e)$ -disks, define pruning fronts and prove some propositions which will be used in Section 5. In Section 4 we state and prove some results about isotopies of homeomorphisms of the plane, which will also be needed in Section 5. Although these results are folkloric, we decided to present them for completeness; the proofs given are rather elementary. Section 5 contains the proof of the main theorem, as its title suggests. Within the first few pages

we get to define an isotopy which is almost all we need (Proposition 5.4) and the remainder of the section is devoted to showing how this isotopy works and how we fix it in order to get the final isotopy  $H$  (which depends, of course, on  $P$ .) It is only in Section 6 that we get to the second part of the title — the formation of horseshoes. We present three examples of pruning fronts for Smale’s horseshoe map. The first of which is, in fact, a family of such examples and produces, via the main theorem, a family of homeomorphisms of the plane whose dynamics mimics that of a full unimodal family of endomorphisms of the interval. The second example gives rise to a ‘renormalizable’ map, that is, a homeomorphism which interchanges two closed disks. The second iterate restricted to each one of these disks is again a full horseshoe. Finally, in the third example we present a pruning front which gives rise to a ‘lax pseudo-Anosov’ homeomorphism. Together these examples should suggest different ways in which a horseshoe can be formed.

A word about the figures is in order. One of the hardest things for me during the preparation of this work was to translate into precise mathematical statements the pictures I had in my mind. I decided, therefore, to add to the text all those pictures I had to draw over and over for myself before I understood what were the right mathematical statements that described them. I hope they will be helpful to the reader, for as the saying goes, “a picture is worth a thousand words.”

ACKNOWLEDGEMENTS: The research presented herein comprises my Ph.D. dissertation done at the Graduate Center of The City University of New York (CUNY) under the supervision of Professor Dennis Sullivan. I would like to thank Professor Sullivan for his guidance during the preparation of this work and the Graduate Center of CUNY for providing a friendly and helpful research atmosphere. I had several discussions with Alberto Baidier, Pregrag Cvitanović, Fred Gardiner, Toby Hall, Michael Handel, Ronnie Mainieri, Charles Tresser and Nick Tuffillaro and I would like to thank them for their help.

## 1 Preliminaries

We will denote the 2-dimensional plane  $\pi$  or  $\mathbb{R}^2$ . A *Jordan curve*  $J$  is the homeomorphic image of the circle  $S^1 = \{(x, y) \in \mathbb{R}^2; x^2 + y^2 = 1\}$  and a *closed arc*  $L$  is the homeomorphic image of the closed interval  $[0, 1]$ , the images of  $\{0\}$  and  $\{1\}$  being its endpoints. By an *open arc* we will mean the set obtained by taking the endpoints away from a closed arc. If  $L$  is a closed arc  $\overset{\circ}{L}$  will denote the corresponding open arc.

The theorems that follow can be found in the books of Newman [Ne], Moise [M] and Whyburn [Wh]. Moore’s book [Mo] is also a good reference although a little less palatable.

**Theorem 1.1 (Jordan Curve Theorem)** *Every Jordan curve separates the plane into two regions  $I$  and  $O$  and is the boundary of each.*

**Definition 1.2** *Let  $J$  be a Jordan curve and  $I$  the bounded region of  $\pi \setminus J$ . We call  $I$  a Jordan domain and sometimes refer to it as the inner domain determined by  $J$ .*

**Theorem 1.3 (Separation Theorem (Whyburn))** *Let  $A$  be compact and  $B$  closed subsets of the plane such that  $A \cap B$  is totally disconnected,  $a \in A \setminus (A \cap B)$ ,  $b \in B \setminus (A \cap B)$  and  $\varepsilon$  a positive number. Then there exists a Jordan curve  $J$  which separates  $a$  and  $b$  and is such that  $J \cap (A \cup B) \subset A \cap B$  and every point of  $J$  is at distance less than  $\varepsilon$  from some point of  $A$ .*

**Definition 1.4** *Let  $U$  be a domain in the plane and  $\alpha$  an open (closed) arc whose endpoints lie on  $\partial U$  and all others lie in  $U$ . Such an  $\alpha$  is called an open (closed) cross-cut.*

**Theorem 1.5** *If both endpoints of a cross-cut  $\alpha$  in a domain  $U \subset \pi$  are on the same component of  $\mathcal{C}U$ , the complement of  $U$ ,  $U \setminus \alpha$  has two components and is contained in the frontiers of both.*

**Corollary 1.6** *Let  $J$  be a Jordan curve,  $I$  its inner domain and  $\alpha \subset I$  a cross-cut. Then  $\alpha$  separates  $I$  into two Jordan domains  $I_1$  and  $I_2$  whose boundaries are  $L_1 \cup \alpha$  and  $L_2 \cup \alpha$ , where  $L_1$  and  $L_2$  are the arcs into which the endpoints of  $\alpha$  separate  $J$ .*

**Theorem 1.7** *Let  $f : J_1 \rightarrow J_2$  be a homeomorphism between the Jordan curves  $J_1$  and  $J_2$ . Then it is possible to extend  $f$  to a homeomorphism  $\tilde{f} : D_1 \rightarrow D_2$  between the closed disks  $D_1 = J_1 \cup I_1$ ,  $D_2 = J_2 \cup I_2$  bounded by  $J_1$  and  $J_2$ .*

**Theorem 1.8 (Alexander)** *In  $\mathbb{R}^n$ , let  $B^n = \{x; |x| \leq 1\}$  and  $S^{n-1} = \partial B^{n-1} = \{x; |x| = 1\}$  and  $f : B^n \rightarrow B^n$  a homeomorphism such that  $f|_{S^{n-1}} \equiv \text{identity}$ . Then  $f$  is isotopic to the identity through an isotopy that fixes the boundary pointwise.*

## 2 Plane Topology

In this section we will develop some plane topology preliminaries we will need later on.

NOTATION: Unless stated explicitly otherwise, we will use the following notations:  $J$  will stand for a Jordan curve,  $I$  and  $O$  for its inner and outer domains respectively, and  $D$  for the closed disk  $I \cup J$ . If  $D$  is a closed disk we will sometimes use  $I(D)$  to denote its inner domain. Subscripts will

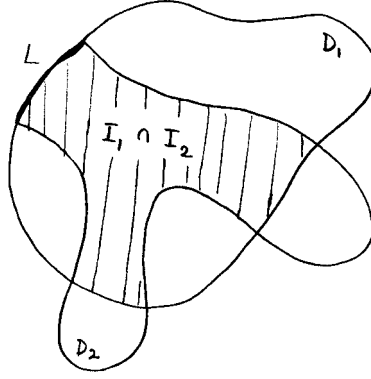

Figure 1: Two disks on the same side of the arc  $L$ .

match in the obvious way, so that the inner domain determined by the Jordan curve  $J_1$  is  $I_1$  and  $D_1 = I_1 \cup J_1$ , etc.

If  $k$  is a positive integer  $\underline{k}$  will stand for the set  $\{1, 2, \dots, k\}$ .

**Definition 2.1** Let  $J_1, \dots, J_n$  be Jordan curves and  $L \subset J_1 \cap \dots \cap J_n$  an arc. We say the closed disks  $D_1, \dots, D_n$  lie on the same side of  $L$ , denoted  $D_1, \dots, D_n|_L$ , if  $L \subset \overline{I_1 \cap \dots \cap I_n}$  (see figure 1.)

**Proposition 2.2** In the plane  $\pi$ , let  $A$  be a closed arc and  $B$  a closed set such that  $A \cap B \subset \{\text{endpoints of } A\}$  and there exists  $\varepsilon > 0$  such that every component of  $B \setminus (A \cap B)$  contains a point at distance greater than  $\varepsilon$  from  $A$ . Then there exists a Jordan curve  $J$  such that  $A \setminus (A \cap B) \subset I$  and  $B \setminus (A \cap B) \subset O$  where  $I$  and  $O$  are the bounded and unbounded components of  $\mathcal{C}J$  (the complement of  $J$  in  $\pi$ ) respectively, and  $J \cap (A \cup B) \subset A \cap B \subset \{\text{endpoints of } A\}$ .

PROOF: Let  $a \in A \setminus (A \cap B)$  and  $b \in B \setminus (A \cap B)$  such that  $d(b, A) > \varepsilon$ . By Theorem 1.3, there exists a Jordan curve  $J$  separating  $a$  from  $b$ , such that  $J \subset V_\varepsilon(A)$  (the  $\varepsilon$ -neighborhood about  $A$ ) and  $J \cap (A \cup B) \subset A \cap B$ .

First notice that  $I \subset V_\varepsilon(A)$ . This is so because  $D = J \cup I$  is compact and since  $A$  is also compact, there exist  $x \in A$  and  $y \in D$  which realize  $\sup\{d(x, y); x \in A, y \in D\}$ . We claim  $y \in J$  for if  $y \in I$  there would exist  $\delta > 0$  such that  $V_\delta(y) \subset I$  and in  $V_\delta(y)$  there must be a point whose distance to  $x$  is greater than  $d(x, y)$ . This shows that if  $J$  is contained in  $V_\varepsilon(A)$  then so is  $D = J \cup I$ .

Since  $b \notin V_\varepsilon(A)$ ,  $b \in O$  and since  $J$  separates  $a$  from  $b$ ,  $a \in I$ . But  $A \setminus (A \cap B)$  is a connected point set disjoint from  $J$  and  $a \in A \setminus (A \cap B)$  so that  $A \setminus (A \cap B) \subset I$ . Also, we assumed that

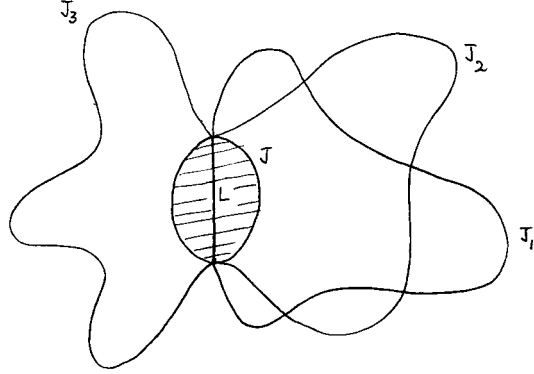

Figure 2: A Jordan neighborhood of a common arc  $L$ .

each connected component of  $B \setminus (A \cap B)$  had a point outside of  $V_\varepsilon(A)$ , and therefore in  $O$ . Since  $B \setminus (A \cap B)$  is disjoint from  $J$ ,  $B \setminus (A \cap B) \subset O$ , as we wanted.  $\square$

In the proofs of the statements that follow, indexed unions and intersections will be assumed to range from  $i = 1$  to  $i = n$ .

**Corollary 2.3** *Let  $J_1, \dots, J_n$  be Jordan curves and  $L \subset \bigcap_{i=1}^n J_i$  a closed arc. Then there exists a Jordan curve  $J$  such that  $\overset{\circ}{L} \subset I$  and such that  $\left(\bigcup_{i=1}^n J_i\right) \setminus L \subset O$ .*

PROOF: Let  $\varepsilon_i = \sup\{d(x, L); x \in J_i \setminus L\}$ . Since  $L$  is a closed arc,  $J_i \setminus \overline{L} \neq \emptyset$  and thus  $\varepsilon_i > 0$ . Let  $A = L$ ,  $B = \overline{\left(\bigcup J_i\right) \setminus L} = \bigcup \overline{J_i \setminus L}$  and  $\varepsilon = \frac{1}{2} \min \varepsilon_i$ . Then  $A \cap B = \{\text{endpoints of } A\}$  and  $B \setminus (A \cap B) = \bigcup (J_i \setminus L)$ , every component of which has a point at distance greater than  $\varepsilon$  from  $A$ . We can then apply Proposition 2.2 in order to find the desired Jordan curve  $J$  (see figure 2.)  $\square$

**Corollary 2.4** *With the notation of Corollary 2.3,  $J \cap L = \{\text{endpoints of } L\}$  and thus  $L$  is a cross-cut in  $I$ .*

PROOF: Since  $\overset{\circ}{L} \subset I$ ,  $L \subset \overline{I} = I \cup J$  so that  $\{\text{endpoints of } L\} \subset I \cup J$ . On the other hand both endpoints of  $L$  are accumulation points of each  $J_i \setminus L$  so that  $\{\text{endpoints of } L\} \subset \left(\overline{\bigcup J_i}\right) \setminus L \subset \overline{O} = O \cup J$ . Therefore  $\{\text{endpoints of } L\} \subset J$ .  $\square$

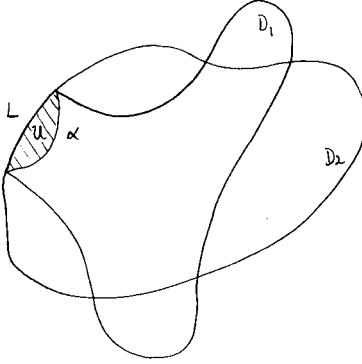

Figure 3:  $D_1$  and  $D_2$  are on the same side of  $L$  and  $\alpha$  is a cross-cut in both  $D_1$  and  $D_2$ .

**Corollary 2.5** *Let  $J$  be a Jordan curve, and  $L \subset J$  a closed arc. Then for any  $\varepsilon > 0$  there exists an open cross-cut  $\alpha \subset I \cap V_\varepsilon(L)$  with the same endpoints as  $L$ .  $\square$*

**Proposition 2.6** *The closed disks  $D_1, \dots, D_n$  lie on the same side of a closed arc  $L$  if and only if there exists an open arc  $\alpha \subset \bigcap_{i=1}^n I_i$  with the same endpoints as  $L$ . As a consequence, if  $U$  is the Jordan domain bounded by  $\alpha \cup L$ ,  $U \subset \bigcap_{i=1}^n I_i$ .*

PROOF: If there exists such an arc, and  $U$  is the Jordan domain bounded by  $\alpha \cup L$ , by Theorem 1.1,  $\alpha \cup L \subset \overline{U} \subset \left(\overline{\bigcap I_i}\right)$ . Therefore  $D_1, \dots, D_n|_L$ .

If  $D_1, \dots, D_n|_L$ , then  $L \subset \bigcap J_i$  and we can use Proposition 2.3 to find a Jordan curve  $J$  satisfying the conclusions of that proposition. By Corollary 2.4 and Corollary 1.6,  $L$  separates  $I$  into two Jordan domains  $U$  and  $V$ . Notice that since  $U \cup V = I \setminus L$ ,  $U \cup V$  does not intersect  $L$  or  $(\bigcup J_i) \setminus L$ , that is,  $U \cup V \subset \mathcal{C}(\bigcup J_i)$ .

Since  $\overset{\circ}{L} \subset \bigcap I_i$ ,  $\overset{\circ}{L} \subset I$  and  $L \cap (\bigcap I_i) = \emptyset$ ,  $(\bigcap I_i) \cap (U \cup V) \neq \emptyset$ . Assume  $U \cap (\bigcap I_i) = \emptyset$ . Since  $U \subset \mathcal{C}(\bigcup J_i)$  and  $U$  is connected,  $U \subset (\bigcap I_i)$ . Now,  $U$  is bounded by  $\alpha \cup L$ , where  $\alpha$  is one of the open arcs into which the endpoints of  $L$  separate  $J$  (see figure 3.) Since  $J \cap (\bigcup J_i) = \{\text{endpoints of } L\}$ ,  $\alpha \cap (\bigcup J_i) = \emptyset$  and since  $\alpha \subset \overline{U} \subset \overline{\bigcap I_i}$ ,  $\alpha \subset \bigcap I_i$ .

Therefore  $\alpha$  is the arc we were after.  $\square$

**Corollary 2.7 (of the proof)** *In Proposition 2.6,  $\alpha$  may be taken to lie in a  $\varepsilon$ -neighborhood of  $L$ , for any  $\varepsilon$  chosen in advance.  $\square$*

REMARK: The arc  $\alpha$  of Proposition 2.6 and Corollary 2.7 is clearly a cross-cut in each of the domains  $I_i$  for each  $i \in \underline{n}$ .

**Proposition 2.8** *If  $D_1, \dots, D_n|_{L'}$  and  $L$  is the connected component of  $\bigcap_{i=1}^n J_i$  containing  $L'$ , then  $D_1, \dots, D_n|_L$ .*

PROOF: Let  $J$  be a Jordan curve as in Corollary 2.3 and  $U$  and  $V$  the components of  $J \setminus L$ . By Corollary 2.4,  $U \cup V \subset \mathcal{C}(\bigcup J_i)$ . Since  $\overset{\circ}{L'} \subset \overset{\circ}{L} \subset I$  and  $D_1, \dots, D_n|_{L'}$ , by the same reasoning as in the proof of Proposition 2.6,  $(\bigcap I_i) \cap (U \cup V) \neq \emptyset$ , say,  $(\bigcap I_i) \cap U \neq \emptyset$ . Since  $U \subset \mathcal{C}(\bigcup J_i)$ ,  $U \subset \bigcap I_i$ . Thus, if  $\partial U = L \cup \alpha$ ,  $\alpha$  satisfies the conditions of Proposition 2.6, which shows that  $D_1, \dots, D_n|_L$  as we wanted.  $\square$

**Proposition 2.9** *If  $D_1, D_2|_L, D_2, D_3|_{L'}$  and  $L'' \subset L \cap L'$  then  $D_1, D_2, D_3|_{L''}$ .*

PROOF: The proof is similar to the previous ones and is left to the reader.  $\square$

**Proposition 2.10** *Let  $J_0, J_1, \dots, J_n$  be Jordan curves,  $L \subset J_0$  an open arc and for  $i \in \underline{n}$ ,  $L \cap \overline{I_0 \cap I_i} = \emptyset$ . Then given  $\varepsilon > 0$  there exists an open cross-cut  $\alpha$  in  $I_0$  joining the endpoints of  $L$  such that  $\alpha \subset V_\varepsilon(L)$  and if  $U$  is the Jordan domain bounded by  $\alpha \cup L$ , then  $(U \cup \alpha) \cap D_i = \emptyset$  for each  $i \in \underline{n}$ .*

PROOF: Consider the set  $B = (J_0 \setminus L) \cup \left[ \overline{I_0 \cap (\bigcup D_i)} \right]$ .  $B$  is clearly closed, since  $L$  is an open arc, and we claim that  $B \cap L = \emptyset$ . Since  $I_0$  is open, it is an exercise to show that  $\overline{I_0 \cap I_i} = \overline{I_0 \cap D_i}$ . Thus our assumption that  $L_0 \cap \overline{I_0 \cap I_i} = \emptyset$  is equivalent to  $L \cap \overline{I_0 \cap D_i} = \emptyset$  for each  $i \in \underline{n}$ . Since  $\overline{I_0 \cap \bigcup D_i} = \bigcup \overline{I_0 \cap D_i}$ ,  $L \cap (\overline{I_0 \cap D_i}) = \emptyset$  and clearly  $L \cap (J_0 \setminus L) = \emptyset$ , so that  $B \cap L = \emptyset$ .

Now let  $C$  be a component of  $\overline{I_0 \cap D_i}$  for some  $i \in \underline{n}$  and assume  $C \cap (J_0 \setminus L) = \emptyset$ . Since  $C \cap L = \emptyset$ ,  $C \cap J_0 = \emptyset$  and it follows that  $C \subset I_0$ . But  $D_i$  is connected so that  $C = D_i$ . This shows that if a component of  $B$  is not that which contains  $J_0 \setminus L$ , it must consist of the union of one or more of the closed disks  $D_i$ . From this it is not hard to see that there exists  $\varepsilon > 0$  such that every component of  $B \setminus \{\text{endpoints of } L\}$  contains a point at distance greater than  $\varepsilon$  from  $L$ . Let  $A = \overline{L}$  and apply Proposition 2.2 to  $A, B$  and  $\varepsilon$  as above to find a Jordan curve  $J$  such that  $A \setminus (A \cap B) = \overline{L} \setminus \{\text{endpoints of } L\} = L \subset I$ ,  $B \setminus (A \cap B) = B \setminus \{\text{endpoints of } L\} \subset O$  and  $J \cap (A \cup B) \subset A \cap B = \{\text{endpoints of } L\}$ . Since  $L \subset I$  and  $J_0 \setminus L \subset \overline{O}$ ,  $L$  is a cross-cut in  $I$



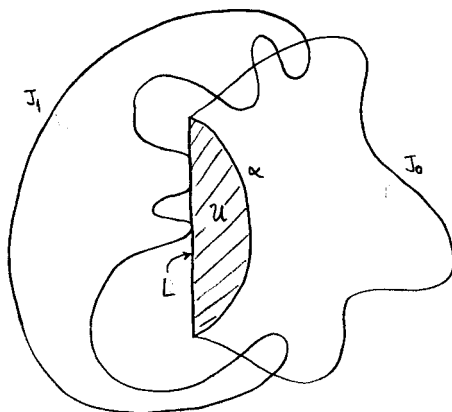

Figure 4: The curve  $J_1$  only touches the arc  $L$  from the outer domain determined by  $J_0$ .

and  $I \setminus L = U \cup V$ , where  $U$  and  $V$  are disjoint Jordan domains. Since  $I \cap (J_0 \setminus L) = \emptyset$ ,  $I \setminus L = I \setminus [L \cup (J_0 \setminus L)] = I \setminus J_0$  and it follows that  $I \setminus L = (I \cap I_0) \cup (I \cap O_0)$  so that either  $U = I \cap I_0$  and  $V = I \cap O_0$  or vice versa. Assume  $U = I \cap I_0$  (see figure 4.) Then  $U \cap D_i = \emptyset$  for every  $i \in \underline{n}$  since  $U = I \cap I_0$  and  $I \cap \overline{I_0 \cap \bigcup D_i} = \emptyset$ . Also, if  $\alpha$  is the arc of  $J \setminus (A \cup B)$  for which  $\partial U = \alpha \cup L$ , it is clear that  $\alpha \subset I_0$  and since  $\alpha \cap \overline{I_0 \cap \bigcup D_i} = \emptyset$ ,  $\alpha \cap \bigcup D_i = \emptyset$ . Therefore,  $\alpha$  is the arc we were after.  $\square$

**Definition 2.11** Let  $A$  be a Jordan curve or an arc and  $L, L' \subset A$  closed arcs. We say that  $L$  and  $L'$  are unlinked if either  $L \subset L'$  or  $L' \subset L$  or  $L$  and  $L'$  intersect at most at endpoints.

REMARK: Notice that saying that  $L$  and  $L'$  are unlinked in a Jordan curve is more than the usual definition of their endpoints being unlinked.

**Proposition 2.12** Let  $J$  be a Jordan curve and  $L_1, \dots, L_n \subset J$  be pairwise unlinked closed arcs. Then for every  $\varepsilon > 0$  there exist disjoint open cross-cuts  $\alpha_i \subset I \cap V_\varepsilon(L_i)$  joining the endpoints of  $L_i$ , for each  $i \in \underline{n}$ .

PROOF: We will use induction on the number  $n$  of arcs. For  $n = 1$ , the statement is true by Corollary 2.5. Assume we have proven the statement for collections of arcs with up to  $n - 1$  elements and  $L_1, \dots, L_n$  are unlinked. Use Corollary 2.5 to find an open cross-cut  $\alpha_1 \subset I \cap V_\varepsilon(L_1)$  joining the endpoints of  $L_1$ . Then for  $i > 1$ , since  $L_i, L_1$  are unlinked, either  $L_i \subset L_1$  or  $L_i \subset \overline{J \setminus L_1}$ .

Let  $L_{i_1}, \dots, L_{i_k} \subset L_1$  and  $L_{j_1}, \dots, L_{j_m} \subset \overline{J \setminus L_1}$ . These are collections of unlinked arcs with fewer than  $n$  elements and since  $L_{i_1}, \dots, L_{i_k} \subset L_1 \cup \alpha_1$  and  $L_{j_1}, \dots, L_{j_m} \subset \overline{J \setminus L_1} \cup \alpha_1$ , by the inductive hypothesis it is possible to find collections of cross-cuts  $\alpha_{i_1}, \dots, \alpha_{i_k}$  and  $\alpha_{j_1}, \dots, \alpha_{j_m}$  satisfying the conclusion of the proposition. Clearly  $\alpha_1, \alpha_{i_1}, \dots, \alpha_{i_k}, \alpha_{j_1}, \dots, \alpha_{j_m}$  is the desired collection for  $L_1, \dots, L_n$ .  $\square$

**Proposition 2.13** *Let  $J_0, \dots, J_n$  be Jordan curves, and  $L_i \subset J_i \cap J_0$ ,  $i \in \underline{n}$ , closed arcs, pairwise unlinked in  $J_0$ , no two of which are identical. Assume that  $D_0, D_i|_{L_i}$  for  $i \in \underline{n}$ . Then for each  $\varepsilon > 0$  there exist disjoint open cross-cuts  $\alpha_i \subset I_0$  joining the endpoints of  $L_i$  such that  $\alpha_i \subset V_\varepsilon(L_i) \cap I_i$  for  $i \in \underline{n}$ .*

PROOF: The proof is by induction on the number  $n$  of curves. If  $n = 1$ , the statement is true by Corollary 2.5. Assume we have proven the statement for collections with fewer than  $n$  curves and  $J_i, L_i$ ,  $i \in \underline{n}$  satisfy the hypotheses above. Among  $L_1, \dots, L_n$  choose all the ones which are not contained in any other (see figure 5.) We may assume without loss of generality that they are the first  $k$  arcs  $L_1, \dots, L_k$ . Since  $L_1, \dots, L_k$  are pairwise unlinked and are not contained in one another, they are pairwise disjoint except possibly at endpoints. By Proposition 2.12 there exist disjoint open cross-cuts  $\gamma_i \subset I_0 \cap V_\varepsilon(L_i)$  joining the endpoints of  $L_i$  for  $i \in \underline{k}$ . Notice that since the arcs  $L_1, \dots, L_k$  are disjoint except possibly at endpoints, the interior  $U_i$  of the disks bounded by  $\gamma_i \cup L_i$ ,  $i \in \underline{k}$  are pairwise disjoint. Moreover by Proposition 2.9 the closed disk bounded by  $\gamma_i \cup L_i$  is on the same side of  $L_i$  as  $D_0$  (the disk bounded by  $J_0$ ) for each  $i \in \underline{k}$ . From Proposition 2.6 it follows that there exist arcs  $\alpha_i \subset U_i \cap I_i$  joining the endpoints of  $L_i$ . Since  $U_i \subset I_0 \cap V_\varepsilon(L_i)$  it is clear that  $\alpha_i$  is a cross-cut in  $I_0$  and  $\alpha_i \subset V_\varepsilon(L_i) \cap I_i$ . Now, the remaining arcs are contained in  $L_1, \dots, L_k$ , since we chose all the arcs which were not contained in any other. For each  $L_i$ ,  $i \in \underline{k}$ , the arcs inside it form an unlinked collection with fewer than  $n$  elements satisfying the hypotheses of the proposition. Therefore by the inductive assumption we are done.  $\square$

### 3 (c, e)-Disks and Pruning Fronts

We will now give a preliminary definition of what we call  $(c, e)$ -disks. Later we will add a dynamical hypothesis which is not necessary at present.

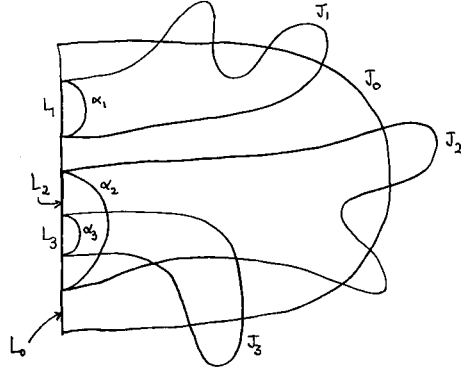

Figure 5: Disjoint cross-cuts joining the endpoints of unlinked arcs.

**Definition 3.1** A closed disk  $D$  is called a  $(c, e)$ -disk if there are closed arcs  $C, E \subset \partial D$  specified such that  $\partial D = C \cup E$  and  $C$  and  $E$  only intersect at endpoints. In other words, for now, a  $(c, e)$ -disk is just a bigon with sides  $C$  and  $E$ . We call the common endpoints of  $C$  and  $E$  the vertices of  $D$ .

**Definition 3.2** Let  $D_1, D_2$  be  $(c, e)$ -disks such that  $I_1 \cap I_2 \neq \emptyset$ . We say  $D_1$  is  $e$ -longer or simply longer than  $D_2$ , denoted  $D_1 \succ D_2$ , if (i), (ii) and (iii) hold (see figure 6):

- (i)  $C_1 \cap I_2 = \emptyset$  and  $E_2 \cap I_1 = \emptyset$ ;
- (ii) if  $C_1 \cap C_2 \neq \emptyset$  then  $C_1 \cup C_2$  is an arc and if  $E_1 \cap E_2 \neq \emptyset$  then  $E_1 \cup E_2$  is an arc;
- (iii) if  $\overset{\circ}{C}_1 \cap \overline{I_1 \cap I_2} \neq \emptyset$  then  $C_1 \subset C_2$  and if  $\overset{\circ}{E}_2 \cap \overline{I_1 \cap I_2} \neq \emptyset$  then  $E_2 \subset E_1$ .

NOTATION: Let  $D$  be a  $(c, e)$ -disk and  $\alpha$  a cross-cut joining the vertices of  $D$ . We have seen that  $\alpha$  separates the interior  $I$  of  $D$  into two Jordan domains whose boundaries are  $C \cup \alpha$  and  $E \cup \alpha$ . We denote them by  $I^c(\alpha)$  and  $I^e(\alpha)$ , respectively, and their closures by  $D^c(\alpha)$ ,  $D^e(\alpha)$  (see figure 7.) Moreover, when the disks are indexed and so are the cross-cuts we will only use the index inside the parentheses so that  $D^c(\alpha_i)$  will denote the disk bounded by  $C_i \cup \alpha_i$ .

CONVENTIONS: If  $D_1, \dots, D_L$  is a collection of  $(c, e)$ -disks, we say they are *related* by  $\succ$  if for any  $i, j \in \underline{L}$  either  $I_i \cap I_j = \emptyset$  or  $D_i \succ D_j$  or  $D_j \succ D_i$ . When nothing is mentioned about a collection of  $(c, e)$ -disks it is assumed they are related by  $\succ$ . Cross-cuts in  $(c, e)$ -disks, when nothing

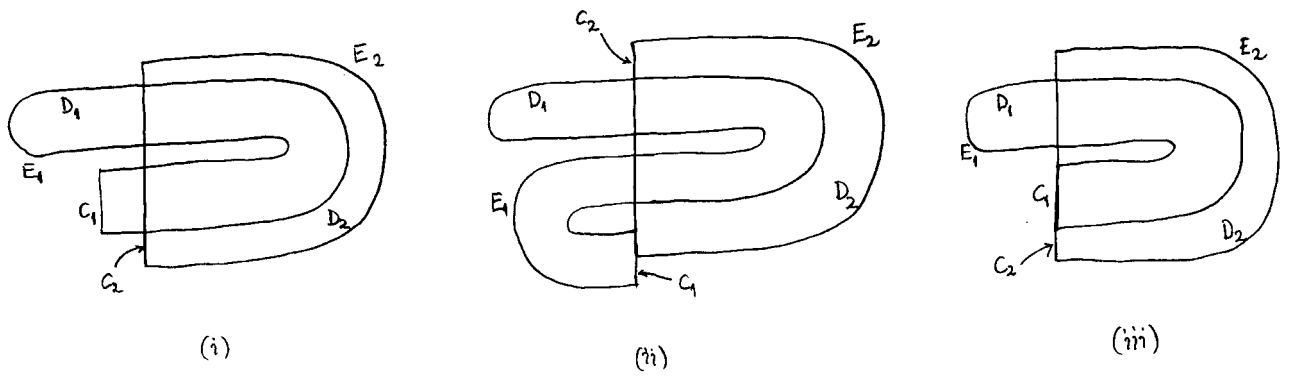

Figure 6: The relation  $\gamma$ .

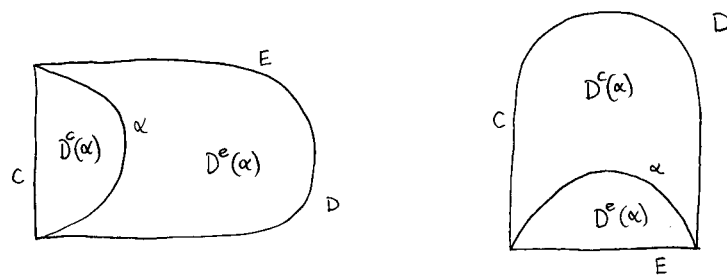

Figure 7: Cut  $(c, e)$ -disks.

is mentioned to the contrary, are assumed to be open and to join the vertices of the disk wherein they lie.

The following propositions are easy consequences of what we have developed so far and we omit the proofs.

**Proposition 3.3** *If  $D$  is a  $(c, e)$ -disk and  $\alpha, \beta, \gamma \subset D$  are open cross-cuts joining vertices such that  $\beta \subset I^c(\alpha)$  and  $\gamma \subset I^e(\alpha)$  then  $I^c(\beta) \subset I^c(\alpha) \subset I^c(\gamma)$  and  $I^e(\beta) \supset I^e(\alpha) \supset I^e(\gamma)$ .  $\square$*

**Proposition 3.4** *Let  $D_1$  and  $D_2$  be  $(c, e)$ -disks and  $D_1 \succ D_2$ . Then*

(i) *if  $\overset{\circ}{C}_1 \cap \overline{I_1 \cap I_2} \neq \emptyset$ , then  $D_1, D_2|_{C_1}$  and*

(ii) *if  $\overset{\circ}{E}_2 \cap \overline{I_1 \cap I_2} \neq \emptyset$ , then  $D_1, D_2|_{E_2}$ .  $\square$*

**Definition 3.5** *A collection of pairs  $\{(D_i, \beta_i)\}_{i=1}^L$ , where  $\{D_i\}_{i=1}^L$  is a collection of  $(c, e)$ -disks related by  $\succ$  and  $\{\beta_i \subset D_i\}_{i=1}^L$  is a collection of open cross-cuts joining vertices, will be called a cut collection.*

**Proposition 3.6** *Let  $D_1$  and  $D_2$  be  $(c, e)$ -disks and  $D_1 \succ D_2$ . If  $C_1 = C_2$  or  $E_1 = E_2$  then  $D_1 = D_2$ .*

PROOF: Assume  $C_1 = C_2$ . Then the endpoints of  $E_1$  and  $E_2$  coincide (since they are the same as those of  $C_1$  and  $C_2$ ) and, by (ii) in the definition of  $\succ$ ,  $E_1 \cup E_2$  is an arc. But this can only happen if  $E_1 = E_2$ .  $\square$

**Proposition 3.7** *If  $D_1, D_2$  are  $(c, e)$ -disks and  $D_1 \succ D_2$  and  $D_2 \succ D_1$  then  $D_1 = D_2$ .*

PROOF: The proof is easy and is left to the reader.  $\square$

**Proposition 3.8** *Let  $\{(D_i, \beta_i)\}_{i=0}^L$  be a cut collection and  $\varepsilon$  a positive number. If  $D_0 \not\prec D_i$  (i.e., either  $I_0 \cap I_i = \emptyset$  or  $D_0 \succ D_i$  and  $D_0 \neq D_i$ ) for every  $i \in \underline{L}$  then there exists an open cross-cut  $\alpha_0 \subset I^c(\beta_0) \cap V_\varepsilon(C_0)$  joining vertices such that for each  $i \in \underline{L}$  either (i) or (ii) holds:*

(i) *if  $\overset{\circ}{C}_0 \cap \overline{I_0 \cap I_i} \neq \emptyset$  then  $[I^c(\alpha_0) \cup \alpha_0] \subset I^c(\beta_i)$ ;*

(ii) *otherwise  $[I^c(\alpha_0) \cup \alpha_0] \cap D_i = \emptyset$ .*

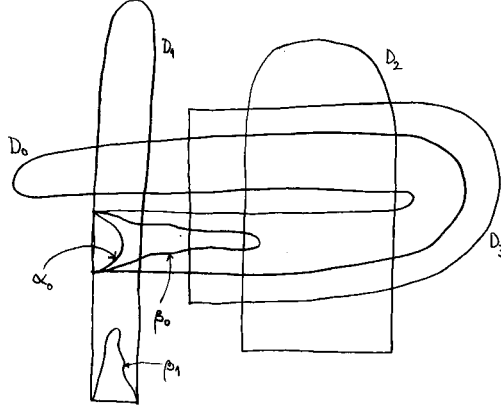

Figure 8: A cut collection where  $D_0 \succ D_i$  for every  $i \in \underline{L}$ .

If, on the other hand,  $D_0 \not\succeq D_i$  for every  $i \in \underline{L}$ , then there exists an open cross-cut  $\alpha_0 \subset I^e(\beta_0) \cap V_\varepsilon(E_0)$  such that for each  $i \in \underline{L}$  either (iii) or (iv) holds:

(iii) if  $\overset{\circ}{E}_0 \cap \overline{I_0} \cap I_i \neq \emptyset$  then  $[I^e(\alpha_0) \cup \alpha_0] \subset I^e(\beta_i)$ ;

(iv) otherwise  $[I^e(\alpha_0) \cup \alpha_0] \cap D_i = \emptyset$ .

PROOF: We will prove (i) and (ii), the proof of (iii) and (iv) being analogous. Divide the disks  $D_i$  into two groups: (i) those for which  $C_0 \cap \overline{I_0} \cap I_i \neq \emptyset$  and (ii) those for which  $C_0 \cap \overline{I_0} \cap I_i = \emptyset$ . If  $D_i$  is in group (i),  $I_0 \cap I_i \neq \emptyset$ , so that by our assumption  $D_0 \succ D_i$  and, by Proposition 3.4,  $D_0, D_i|_{C_0}$ . Clearly  $D^c(\beta_0), D_0|_{C_0}$  and  $D^c(\beta_i), D_i|_{C_i}$  and, since  $C_0 \subset C_i$ , we see that  $D^c(\beta_0), D_0|_{C_0}, D_0, D_i|_{C_0}$  and  $D_i, D^c(\beta_i)|_{C_i}$ , by Proposition 2.9, imply that  $D^c(\beta_0), D^c(\beta_i)|_{C_0}$  for every  $D_i$  in group (i). It now follows from Proposition 2.6 and Corollary 2.7 that there exists an open cross-cut  $\alpha \subset I^c(\beta_0) \cap V_\varepsilon(C_0)$  such that  $[I^c(\alpha) \cup \alpha] \subset I^c(\beta_i)$ .

On the other hand, for the disks  $D_j$  in group (ii),  $C_0 \cap \overline{I_0} \cap I_j = \emptyset$  and since  $I^c(\alpha) \subset I_0$ , it is also the case that  $C_0 \cap \overline{I^c(\alpha)} \cap I_j = \emptyset$ . Thus, by Proposition 2.10 there exists an open cross-cut  $\alpha_0$  in  $I^c(\alpha)$  such that for every  $D_j$  in group (ii),  $[I^c(\alpha_0) \cup \alpha_0] \cap D_j = \emptyset$ . It is clear that such  $\alpha_0$  also satisfies  $[I^c(\alpha_0) \cup \alpha_0] \subset I^c(\beta_i)$  for every  $D_i$  in group (i) (see figure 8.)

In the event that all the disks belong to one or the other of the groups, the modifications necessary in the above proof are minor and are left to the reader.  $\square$

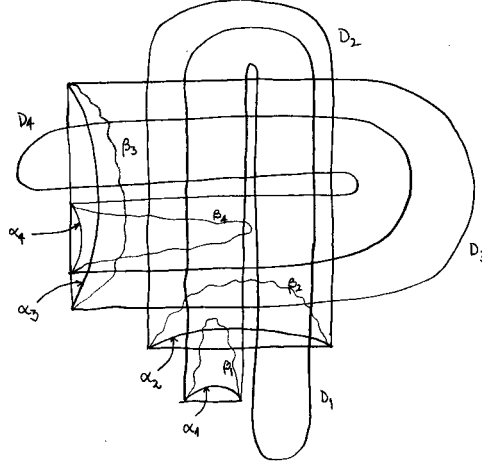

Figure 9:  $\{\alpha_1, \alpha_2\}$  is a  $(\varepsilon, e)$ -collection and  $\{\alpha_3, \alpha_4\}$  is a  $(\varepsilon, c)$ -collection, both compatible with  $\{(D_i, \beta_i)\}_{i=1}^4$ .

**Definition 3.9** Let  $\{(D_i, \beta_i)\}_{i=1}^L$  be a cut collection,  $S \subset \underline{L}$  and  $\varepsilon > 0$ . The collection  $\{\alpha_i\}_{i \in S}$  of disjoint open cross-cuts is said to be a  $(\varepsilon, c)$ -collection compatible with  $\{(D_i, \beta_i)\}_{i=1}^L$  (see figure 9) if  $\alpha_i \subset I^c(\beta_i) \cap V_\varepsilon(C_i)$  and for every  $i \in S$  and  $j \in \underline{L}$  such that  $D_i \not\prec D_j$  either (i) or (ii) holds:

(i) if  $\overset{\circ}{C}_i \cap \overline{I_i} \cap \overline{I_j} \neq \emptyset$  then  $[I^c(\alpha_i) \cup \alpha_i] \subset I^c(\beta_j)$ ;

(ii) otherwise  $[I^c(\alpha_i) \cup \alpha_i] \cap D_j = \emptyset$ .

The collection  $\{\alpha_i\}_{i \in S}$  is called a  $(\varepsilon, e)$ -collection compatible with  $\{(D_i, \beta_i)\}_{i=1}^L$  if  $\alpha_i \subset I^e(\beta_i) \cap V_\varepsilon(E_i)$  and for every  $i \in S$  and  $j \in \underline{L}$  such that  $D_i \not\prec D_j$  either (iii) or (iv) holds:

(iii) if  $\overset{\circ}{E}_i \cap \overline{I_i} \cap \overline{I_j} \neq \emptyset$  then  $[I^e(\alpha_i) \cup \alpha_i] \subset I^e(\beta_j)$ ;

(iv) otherwise  $[I^e(\alpha_i) \cup \alpha_i] \cap D_j = \emptyset$ .

REMARKS: Notice that if  $\{\alpha_i\}_{i \in S}$  is a  $(\varepsilon, c)$ -collection compatible with  $\{(D_i, \beta_i)\}$  and  $\{\gamma_i\}_{i \in S}$  is a collection of open cross-cuts joining the vertices of  $D_i$  and such that  $\gamma_i \subset I^c(\alpha_i)$ ,  $\{\gamma_i\}_{i \in S}$  is also a  $(\varepsilon, c)$ -collection compatible with  $\{(D_i, \beta_i)\}$ . If moreover  $\gamma_i \subset V_{\varepsilon'}(C_i)$  then  $\{\gamma_i\}_{i \in S}$  is a  $(\varepsilon', c)$ -collection. The analogous statement holds true for  $(\varepsilon, e)$ -collections.

WARNING: As the reader may have already noticed, statements about  $c$ -“things” and  $e$ -“things” are “dual” to one another and most proofs are totally analogous in both cases. We will henceforward,

whenever there is nothing essentially different between the two, present only the “c-proof” without further comments.

**Proposition 3.10** *Let  $\{(D_i, \beta_i)\}_{i=1}^L$  be a cut collection,  $\{\alpha_i\}_{i \in S}$  a  $(\varepsilon, c)$ -collection and  $\{\alpha'_i\}_{i \in S}$  a  $(\varepsilon, e)$ -collection both compatible with  $\{(D_i, \beta_i)\}_{i=1}^L$ . If  $i, j \in S$  are such that  $D_i \succ D_j$  and  $D_i \neq D_j$  then:*

- (i)  $\overset{\circ}{C}_i \cap \overline{I_i} \cap \overline{I_j} \neq \emptyset$  implies  $[I^c(\alpha_i) \cup \alpha_i] \subset I^c(\alpha_j)$  and
- (ii)  $\overset{\circ}{E}_j \cap \overline{I_i} \cap \overline{I_j} \neq \emptyset$  implies  $[I^e(\alpha'_j) \cup \alpha'_j] \subset I^e(\alpha'_i)$ .

PROOF: From the definition of  $\succ$  and Proposition 3.4 it follows, under the hypotheses above, that  $C_i \subset C_j$  and  $D_i, D_j|_{C_i}$  and from the definition of  $(\varepsilon, c)$ -collection, that  $[I^c(\alpha_i) \cup \alpha_i] \subset I^c(\beta_i)$ . Therefore both  $\alpha_i$  and  $\alpha_j$  are open cross-cuts in  $I^c(\beta_j)$ . Since they are assumed to be disjoint (by definition),  $\alpha_i$  joins the endpoints of  $C_i$ ,  $\alpha_j$  those of  $C_j$  and  $C_i \subset C_j$ , it must be the case that  $[I^c(\alpha_i) \cup \alpha_i] \subset I^c(\alpha_j)$ , as we wanted.  $\square$

**Proposition 3.11** *Let  $\{\alpha_i\}_{i \in S}$  be a  $(\varepsilon, c)$ -collection compatible with the cut collection  $\{(D_i, \beta_i)\}_{i=1}^L$  and  $\{\beta'_i \subset D_i\}_{i=1}^L$  a collection of cross-cuts such that  $\beta'_i \subset D^e(\beta_i)$  for each  $i \in \underline{L}$ . Then  $\{\alpha_i\}_{i \in S}$  is also compatible with  $\{(D_i, \beta'_i)\}_{i=1}^L$ . If above we change  $(\varepsilon, c)$ - to  $(\varepsilon, e)$ - and  $D^e(\beta_i)$  to  $D^c(\beta_i)$  the resulting statement is true.*

PROOF: Since the collection of  $(c, e)$ -disks remains unchanged all there is to check is that if  $i \in S$  and  $j \in \underline{L}$  are such that  $D_i \succ D_j$ ,  $\overset{\circ}{C}_i \cap \overline{I_i} \cap \overline{I_j} \neq \emptyset$  implies  $[I^c(\alpha_i) \cup \alpha_i] \subset I^c(\beta'_j)$ . But by the “closed” version of Proposition 3.3,  $\beta'_j \subset D^e(\beta_j)$  implies that  $I^c(\beta'_j) \supset I^c(\beta_j)$ . The result now follows.  $\square$

**Corollary 3.12** *Let  $\{\alpha_i\}_{i \in S}$  and  $\{\alpha'_i\}_{i \in S'}$  be a  $(\varepsilon, c)$ - and a  $(\varepsilon', e)$ -collection respectively, both compatible with the cut collection  $\{(D_i, \beta_i)\}_{i=1}^L$ . Then  $\{\alpha_i\}_{i \in S}$  is a  $(\varepsilon, c)$ -collection compatible with the cut collection*

$$\{(D_i, \beta_i), i \in \underline{L} \setminus S'\} \cup \{(D_i, \alpha'_i); i \in S'\}$$

and  $\{\alpha'_i\}_{i \in S'}$  is a  $(\varepsilon, e)$ -collection compatible with

$$\{(D_i, \beta_i); i \in \underline{L} \setminus S\} \cup \{(D_i, \alpha_i); i \in S\}. \quad \square$$



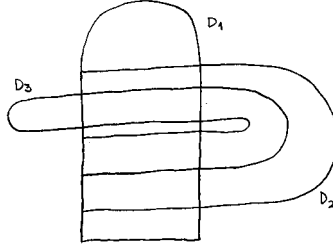

Figure 10: An equivalence class for  $\sim_c$ .  $D_1$  is the distinguished representative.

**Proposition 3.13** *Under the hypotheses of Corollary 3.12, if  $i \in S$  and  $j \in S'$  are such that  $D_i \not\sim_c D_j$ , then  $\alpha_i \cap \alpha_j = \emptyset$ .*

PROOF: The proof is easy and is left to the reader.  $\square$

We still have to show that  $(\varepsilon, c)$ - and  $(\varepsilon, e)$ -collections exist. In the proof we will use the definition and the proposition below.

**Definition 3.14** *Let  $\{D_i\}$  be a collection of  $(c, e)$ -disks related by  $\succ$ . We say  $D_i$  and  $D_j$  are  $c$ -equivalent, and write  $D_i \sim_c D_j$ , if there exists  $D_k$  in the collection such that  $C_i, C_j \subset C_k$  and  $D_i, D_k|_{C_i}$  and  $D_j, D_k|_{C_j}$ . We define  $e$ -equivalence analogously by changing  $c$ -sides to  $e$ -sides above, and denote it by  $\sim_e$  (see figure 10.)*

REMARK: Notice that by this definition,  $D_i \sim_c D_j$  if  $C_i \subset C_j$  and  $D_i, D_j|_{C_j}$  or vice versa and analogously for  $\sim_e$ .

**Proposition 3.15** *The relations  $\sim_c$  and  $\sim_e$  defined above are equivalence relations. If the collection  $\{D_i\}_{i=1}^L$  is finite, each equivalence class for  $\sim_c$  ( $\sim_e$ ) has a distinguished representative whose  $c$ -( $e$ -)side contains the  $c$ -( $e$ -)sides of all other disks in its  $c$ -( $e$ -)equivalence class. Moreover, in each  $c$ -( $e$ -)equivalence class the  $c$ -( $e$ -)sides are unlinked in the  $c$ -side of its distinguished representative.*

PROOF: That  $\sim_c$  is reflexive and symmetric is clear. In order to prove transitivity, assume  $D_i \sim_c D_j$  and  $D_j \sim_c D_k$ . This means there exist  $D_l, D_m$  in the collection such that  $C_i, C_j \subset C_l$  and  $D_i, D_l|_{C_i}$ ,  $D_j, D_l|_{C_j}$  and  $C_j, C_k \subset C_m$  and  $D_j, D_m|_{C_j}$ ,  $D_k, D_m|_{C_k}$ . It follows from Proposition 2.9

that  $D_l, D_m|_{C_j}$  and thus either  $D_l \succ D_m$  or  $D_m \succ D_l$ . We may assume  $D_l \succ D_m$ , the other case being analogous. Then, since  $C_j \subset C_l$  and  $D_l, D_m|_{C_j}$ ,  $\overset{\circ}{C}_l \cap \overline{I_l} \cap I_m \neq \emptyset$  and from the definition of  $\succ$  and Proposition 3.4 we can conclude that  $C_l \subset C_m$  and  $D_l, D_m|_{C_l}$ . From this we see that  $C_i \subset C_m$  and  $D_i, D_m|_{C_i}$ , which shows that  $D_i \sim_c D_k$ .

Consider now one  $c$ -equivalence class and let  $D_i$  be an element in it whose  $c$ -side is not strictly contained in the  $c$ -side of any other disk in the same class. If  $D_j \sim_c D_i$  then it must be the case that  $C_j \subset C_i$  for otherwise there would exist  $D_k$  in the collection for which  $C_i, C_j \subset C_k$  and  $D_i, D_k|_{C_i}$  and  $D_j, D_k|_{C_j}$ . But  $D_k \sim_c D_i$  (see the remark just after the definition of  $c$ -equivalence) and if  $C_j \not\subset C_i$ ,  $C_k$  contains  $C_i$  strictly which is contrary to our assumption. This shows that for every  $D_j$  such that  $D_j \sim_c D_i$  we have  $C_j \subset C_i$  and  $D_i, D_j|_{C_j}$ . In order to see that the  $c$ -sides of disks in the  $c$ -equivalence class of  $D_i$  are unlinked in  $C_i$  assume  $D_j \sim_c D_k \sim_c D_i$  and that  $C_j \cap C_k \supset C$ , where  $C$  is a closed arc. Since  $D_i, D_j|_{C_j}$  and  $D_j, D_k|_{C_k}$  by Proposition 2.9, it follows that  $D_j, D_k|_C$ . Then  $I_j \cap I_k \neq \emptyset$  and we must have  $D_j \succ D_k$  or  $D_k \succ D_j$  and by (iii) in the definition of  $\succ$ ,  $C_j \subset C_k$  or  $C_k \subset C_j$ .  $\square$

STANDING CONVENTION: If the lower index in an indexed union or collection is larger than the upper one we will take the union or collection to be empty, so that  $\bigcup_{-n+1}^{n-1} f^k(P) = \emptyset$  when  $n = 0$ . Also, recall that a bar under a positive integer denotes the set of all positive integers smaller than or equal to it:  $\underline{L} = \{1, 2, \dots, L\}$ . If  $L = 0$  we take  $\underline{L}$  to be the empty set as well.

We now go on to prove the existence of  $(\varepsilon, c)$ - and  $(\varepsilon, e)$ -collections (see figure 11.)

**Proposition 3.16** *Let  $\{(D_i(k), \beta_i(k)); k = -1, 0, 1 \text{ and } i \in \underline{L(k)}\}$  (where  $L(k)$  is a nonnegative integer for each  $k = -1, 0, 1$ ) be a cut collection such that if  $k < l$  then  $D_i(k) \not\subset D_j(l)$  for  $i \in \underline{L(k)}$  and  $j \in \underline{L(l)}$ . Then given  $\varepsilon, \delta > 0$  there exist a  $(\delta, e)$ -collection  $\{\alpha_i(-1) \subset D_i(-1)\}_{i=1}^{L(-1)}$  and a  $(\varepsilon, c)$ -collection  $\{\alpha_j(1) \subset D_j(1)\}_{j=1}^{L(1)}$  both compatible with  $\{(D_i(k), \beta_i(k)); k = -1, 0, 1 \text{ and } i \in \underline{L(k)}\}$ .*

PROOF: (See remark before the statement.) We may assume, without loss of generality, that the distinguished representatives in the  $c$ -equivalence classes among  $\{D_i(1); i \in \underline{L(1)}\}$  are the first  $n$  disks  $D_1(1), \dots, D_n(1)$ . For each  $i \in \underline{n}$  consider the cut collection

$$\{(D_j(k), \beta_j(k)); k = -1, 0, 1, j \in \underline{L(k)}, D_j(k) \not\subset D_i(1)\} \cup \{(D_i(1), \beta_i(1))\}.$$

By Proposition 3.8 there exists an open cross-cut  $\alpha_i(1) \subset I^c(\beta_i(1)) \cap V_\varepsilon(C_i(1))$  satisfying (i) and (ii) of that proposition (with  $\alpha_i(1)$  in place of  $\alpha_0$ .) We do the same for every  $i \in \underline{n}$  obtaining

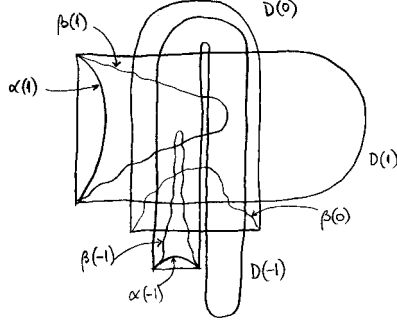

Figure 11:  $\{\alpha(1)\}$  is the  $(\varepsilon, c)$ -collection and  $\{\alpha(-1)\}$  is the  $(\varepsilon, e)$ -collection, both compatible with  $\{(D(k), \beta(k); k = -1, 0, 1)\}$

$\{\alpha_i(1)\}_{i=1}^n$ . These cross-cuts clearly satisfy (i) and (ii) in the definition of  $(\varepsilon, c)$ -collections and  $\alpha_i(1) \subset I^c(\beta_i(1)) \cap V_\varepsilon(C_i(1))$  by construction. In order to see they are disjoint, let  $i, j \in \underline{n}$ . If  $I_i(1) \cap I_j(1) = \emptyset$ ,  $\alpha_i(1) \cap \alpha_j(1) = \emptyset$  since  $\alpha_i(1) \subset I_i(1)$  and  $\alpha_j(1) \subset I_j(1)$ . If  $I_i(1) \cap I_j(1) \neq \emptyset$ , then either  $D_i(1) \succ D_j(1)$  or  $D_j(1) \succ D_i(1)$ , say,  $D_i(1) \succ D_j(1)$ . It follows that  $\overset{\circ}{C}_i(1) \cap \overline{I_i(1)} \cap \overline{I_j(1)} = \emptyset$  for otherwise  $C_i(1) \subset C_j(1)$  and  $D_i(1), D_j(1)|_{C_i(1)}$ , which goes against our assumption that  $C_i(1)$  was the distinguished representative in its  $c$ -equivalence class. From this we can conclude that  $[I^c(\alpha_i(1)) \cup \alpha_i(1)] \cap D_j = \emptyset$  and thus that  $\alpha_i(1) \cap \alpha_j(1) = \emptyset$ . Indeed we have shown more, namely that

$$[I^c(\alpha_i(1)) \cup \alpha_i(1)] \cap [I^c(\alpha_j(1)) \cup \alpha_j(1)] = \emptyset$$

for any  $i, j \in \underline{n}$ .

We now look at the disks in one  $c$ -equivalence class. By Proposition 3.15 the  $c$ -sides of the elements in the class are unlinked in the  $c$ -side of its distinguished representative,  $D_i(1)$  say. By Proposition 2.13 it is possible to find disjoint open cross-cuts  $\alpha_j(1) \subset I^c(\alpha_i(1))$  joining the endpoints of  $C_j(1)$  such that  $\alpha_j(1) \subset I^c(\beta_j(1)) \cap V_\varepsilon(C_j(1))$  for every  $j$  such that  $D_j \sim_c D_i$ . Doing this for each  $c$ -equivalence class we find a collection of disjoint open cross-cuts  $\{\alpha_i(1)\}_{i=1}^{L(1)}$  satisfying the conditions in the definition of a  $(\varepsilon, c)$ -collection compatible with  $\{(D_i(k), \beta_i(k))\}$   $\square$ .

We will now introduce dynamics in our discussion and add to the definition of  $(c, e)$ -disks a new requirement, as we promised earlier. Let  $f : \pi \rightarrow \pi$  be a plane homeomorphism which we will have fixed for the remainder of the time.

(C,E) DYNAMICAL ASSUMPTION: All  $(c, e)$ -disks henceforth will be assumed to satisfy (i) and (ii):

- (i)  $\lim_{n \rightarrow \infty} \text{diam } f^n(C) = 0$ ;
- (ii)  $\lim_{m \rightarrow -\infty} \text{diam } f^m(E) = 0$ .

The main purpose of the present work is to isotop away dynamics of  $f$  in a controlled manner. We will now define sets within which it is possible to do this, namely, to destroy all dynamics within them by an isotopy which is identically equal to  $f$  without them. We call them *pruning fronts* after the work of Predrag Cvitanović [C].

**Definition 3.17** *Let  $\{D_i\}_{i=1}^L$  be a collection of  $(c, e)$ -disks (satisfying the dynamical assumption above) such that (i), (ii) and (iii) hold:*

- (i)  $\succ$  can be extended by transitivity to a partial order on  $\{D_i\}_{i=1}^L$  or, equivalently, there are no “loops”  $D_{i_1} \succ D_{i_2} \succ \dots \succ D_{i_n} \succ D_{i_1}$ ;
- (ii) for every  $n > 0$  and  $i, j \in \underline{L}$ ,  $f^n(D_i) \not\prec D_j$ ;
- (iii) for every  $m < 0$  and  $i, j \in \underline{L}$ ,  $f^m(D_i) \not\prec D_j$ .

Such a collection will be called a pruning collection. Its locus  $\bar{P} = \bigcup_{i=1}^L D_i$  (see [C] and the comments before the definition) will be called a pruning front.

NOTATION: We will use  $\geq$  to denote the extension of  $\succ$  to a partial order and keep  $\succ$  to denote the binary relation as we defined previously.

Before we proceed, let us say a word about finite partially ordered sets. If  $(X, \geq)$  is one such we define the set of *initial elements* of  $X$  to be

$$I(X) = \{x \in X; \forall y \in X, y \leq x \implies y = x\}$$

It is easy to see that if  $X$  is finite and nonempty,  $I(X)$  is nonempty and that no two distinct elements in  $I(X)$  are related by  $\geq$ . Now let  $X_1 = I(X)$  and inductively set  $X_n = I(X \setminus \bigcup_{i=1}^{n-1} X_i)$ .

From what we have said,  $X_n$  is nonempty if  $X \setminus \bigcup_{i=1}^{n-1} X_i$  is nonempty. Since  $X$  is finite, there exists  $n \geq 1$  such that  $X_1, X_2, \dots, X_n$  are all nonempty and for  $m > n$ ,  $X_m = \emptyset$ . Clearly  $X_1, \dots, X_n$  is a partition of  $X$  and if  $X_i$  has  $s_i$  elements we can list the elements of  $X = \{x_1, x_2, x_3, \dots, x_L\}$  so

that the first  $s_1$  elements are those in  $X_1$ , the next  $s_2$  elements are those in  $X_2$  and so on. In this way the subscripts reflect the partial order in the sense that if  $i < j$  then  $x_i \not\geq x_j$ . Having said this we adopt the following

CONVENTION: Henceforth it will be assumed that the subscripts in a pruning collection reflect the partial order  $\geq$  in the sense that if  $i < j$  then  $D_i \not\geq D_j$ . Notice that, in particular, if  $i < j$  then  $D_i \not\asymp D_j$ .

We can now state a proposition containing one of the main ingredients in the proof of the main theorem (see figure 12.)

**Proposition 3.18** *Let  $\{D_i\}_{i=1}^L$  be a pruning collection and  $\{\varepsilon_n\}_{n=0}^\infty$  a sequence of positive numbers converging to zero. Then there exists a collection  $\{\alpha_i(n) \subset f^n(D_i); i \in \underline{L}, n \in \mathbb{Z}\}$  of disjoint open cross-cuts joining the vertices of  $f^n(D_i)$  such that (i) and (ii) below hold:*

(i) *For each  $n \geq 1$ ,  $\{\alpha_i(n); i \in \underline{L}\}$  is a  $(\varepsilon_n, c)$ -collection compatible with*

$$\begin{aligned} & \{(f^k(D_j), \alpha_j(k)); j \in \underline{L}, -n+1 \leq k \leq n-1\} \\ & \cup \{(f^n(D_j), f(\alpha_j(n-1))); j \in \underline{L}\} \end{aligned}$$

(ii) *For each  $m \leq 0$ ,  $\{\alpha_i(m); i \in \underline{L}\}$  is a  $(\varepsilon_{|m|}, C)$ -collection compatible with*

$$\begin{aligned} & \{(f^k(D_j), \alpha_j(k)); j \in \underline{L}, m+1 \leq k \leq -m+1\} \\ & \cup \{(f^m(D_j), f^{-1}(\alpha_j(m+1))); j \in \underline{L}\}. \end{aligned}$$

PROOF: We will let  $m = -n+1$  and use induction on  $n$ . In order to prove the proposition for  $n = 1$ , choose any collection  $\{\beta_i \subset D_i\}_{i=1}^L$  of open cross-cuts joining vertices and apply Proposition 3.16 with  $L(0) = 0$  (so that  $\underline{L}(0) = \emptyset$  and  $\{(D_i(0), \beta_i(0))\} = \emptyset$ ) to the cut collection

$$\mathcal{D} = \{(D_i, \beta_i); i \in \underline{L}\} \cup \{(f(D_i), f(\beta_i)); i \in \underline{L}\}$$

where  $\{(D_i, \beta_i)\}$  and  $\{(f(D_i), f(\beta_i))\}$  play the roles of  $\{(D_i(-1), \beta_i(-1))\}$  and  $\{(D_i(1), \alpha_i(1))\}$  respectively in the statement of that proposition, whereas  $\varepsilon = \varepsilon_1$  and  $\delta = \varepsilon_0$ . By the definition of pruning collection,  $f(D_i) \not\asymp D_j$  for any  $i, j \in \underline{L}$  so that  $\mathcal{D}$  satisfies the hypotheses and we can conclude there exist  $\{\alpha_i(1)\}_{i=1}^L$  and  $\{\alpha_i\}_{i=1}^L$  a  $(\varepsilon_1, c)$ - and a  $(\varepsilon_0, e)$ -collection respectively, both compatible with  $\mathcal{D}$ . Since  $\alpha_i \subset I^e(\beta_i)$  and therefore  $f(\alpha_i) \subset I^e(f(\beta_i))$ , by Proposition 3.11, and Corollary 3.12,  $\{\alpha_i(1)\}_{i=1}^L$  is a  $(\varepsilon_1, c)$ -collection compatible with

$$\{(D_i, \alpha_i); i \in \underline{L}\} \cup \{(f(D_i), f(\alpha_i)); i \in \underline{L}\}.$$

By the same token  $\{\alpha_i\}_{i=1}^L$  is a  $(\varepsilon_0, e)$ -collection compatible with

$$\{(D_i, f^{-1}(\alpha_i(1))); i \in \underline{L}\} \cup \{(f(D_i), a_i(1)); i \in \underline{L}\}.$$

That  $\alpha_i(1) \cap \alpha_j = \emptyset$  for  $i, j \in \underline{L}$  is a consequence of Proposition 3.13. This proves the proposition for  $n = 1$ ,  $m = 0$ .

Assume we have constructed a collection

$$\{\alpha_i(k); i \in \underline{L}, -n + 2 \leq k \leq n - 1\}$$

of disjoint open cross-cuts satisfying the conclusions of the proposition. Consider the cut collection

$$\begin{aligned} \mathcal{D} &= \{(f^n(D_i), f(\alpha_i(n - 1))); i \in \underline{L}\} \\ &\cup \{(f^k(D_i), \alpha_i(k)); i \in \underline{L}, -n + 2 \leq k \leq n - 1\} \\ &\cup \{(f^{-n+1}(D_i), f^{-1}(\alpha_i(-n + 2))); i \in \underline{L}\} \end{aligned}$$

and apply Proposition 3.16 with  $\{(D_i(1), \beta_i(1))\}$ ,  $\{(D_i(0), \alpha_i(0))\}$  and  $\{(D_i(-1), \alpha_i(-1))\}$  equal to the first, second and third collections respectively, in the above union, letting  $\varepsilon = \varepsilon_n$  and  $\delta = \varepsilon_{|-n+1|}$ . From the definition of pruning collection,  $f^n(D_i) \not\prec f^k(D_j)$  for any  $k < n$  and any  $i, j \in \underline{L}$  and  $f^{-n+1}(D_i) \not\prec f^k(D_j)$  for any  $k > -n + 1$  and any  $i, j \in \underline{L}$ , so that the hypotheses of the proposition are satisfied. We may then conclude there exist  $\{\alpha_i(n) \subset f^n(D_i)\}_{i=1}^L$  and  $\{\alpha_i(-n + 1) \subset f^{-n+1}(D_i)\}_{i=1}^L$  a  $(\varepsilon_n, c)$ - and a  $(\varepsilon_{|-n+1|}, e)$ -collection respectively, both compatible with  $\mathcal{D}$ . From Corollary 3.12,  $\{\alpha_i(n)\}_{i=1}^L$  is compatible with

$$\begin{aligned} &\{(f^k(D_i), \alpha_i(k)); i \in \underline{L}, -n + 1 \leq k \leq n - 1\} \\ &\cup \{(f^n(D_i), f(\alpha_i(n - 1))); i \in \underline{L}\} \end{aligned}$$

and  $\{\alpha_i(-n + 1)\}_{i=1}^L$  is compatible with

$$\begin{aligned} &\{(f^k(D_i), \alpha_i(k)); i \in \underline{L}, -n + 2 \leq k \leq n\} \\ &\cup \{(f^{-n+1}(D_i), f^{-1}(\alpha_i(-n + 2))); i \in \underline{L}\}. \end{aligned}$$

That  $\alpha_i(n) \cap \alpha_j(k) = \emptyset$  for  $-n + 1 \leq k \leq n - 1$  and  $\alpha_i(-n + 1) \cap \alpha_j(k) = \emptyset$  for  $-n + 2 \leq k \leq n$  is a consequence of Proposition 3.13. This finishes the induction step and proves the proposition.  $\square$

**Corollary 3.19** *With the notation of Proposition 3.18, for every  $n \in \mathbb{Z}$ ,  $\alpha_i(n) \subset I^c(f(\alpha_i(n - 1)))$  and  $\alpha_i(n) \subset I^e(f^{-1}(\alpha_i(n + 1)))$ .*

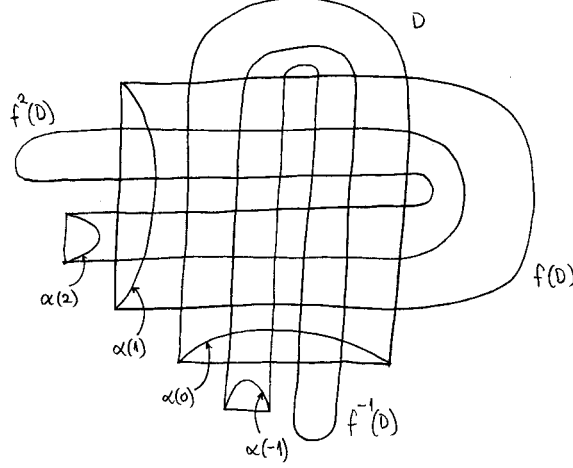

Figure 12: The first few  $\alpha(n)$ 's for a pruning collection containing only one  $(c, e)$ -disk  $D$ .

PROOF: For  $n \geq 1$ , (i) of Proposition 3.18 implies that  $\alpha_i(n) \subset I^c(f(\alpha_i(n-1)))$  whereas (ii) implies that for  $m \leq 0$ ,  $\alpha_i(m) \subset I^e(f^{-1}(\alpha_i(m+1)))$ . By Proposition 3.3,  $f^{-1}(\alpha_i(m+1)) \subset I^c(\alpha_i(m))$  and applying  $f$  to both sides we get  $\alpha_i(m+1) \subset f(I^c(\alpha_i(m))) = I^c(f(\alpha_i(m)))$ . Letting  $n = m+1$  we see that for  $n \leq 1$ ,  $\alpha_i(n) \subset I^e(f(\alpha_i(n-1)))$ , which completes the proof of the first statement. The second is obtained from it using Proposition 3.3 (see figure 13.)  $\square$

The next proposition is nothing but a “fattened” version of Proposition 3.18 (see figure 14.) We could have proven it together with Proposition 3.18 had we stated the “fattened” versions of the propositions we proved before. Although feasible, this would have been rather cumbersome. It is also possible to give a direct proof using the techniques we have used so far. We leave it to the interested reader.

**Proposition 3.20** *Let  $\{\alpha_i(n); i \in \underline{L}, n \in \mathbb{Z}\}$  be as in Proposition 3.18. Then there exist collections of disjoint open cross-cuts  $\{\beta_i(n) \subset f^n(D_i); i \in \underline{L}, n \in \mathbb{Z}\}$  and  $\{\gamma_i(n) \subset f^n(D_i); i \in \underline{L}, n \in \mathbb{Z}\}$  joining vertices such that:*

- (i)  $\beta_i(n) \subset I^c(\alpha_i(n))$  and  $\gamma_i(n) \subset I^e(\alpha_i(n))$ ;
- (ii) for  $n \geq 1$ ,  $\{\gamma_i(n); i \in \underline{L}\}$  is a  $(\varepsilon_n, c)$ -collection compatible with

$$\{(f^k(D_i), \beta_i(k)); i \in \underline{L}, -n+1 \leq k \leq n-1\}$$

$$\cup \{(f^n(D_i), f(\beta_i(n-1))); i \in \underline{L}\};$$

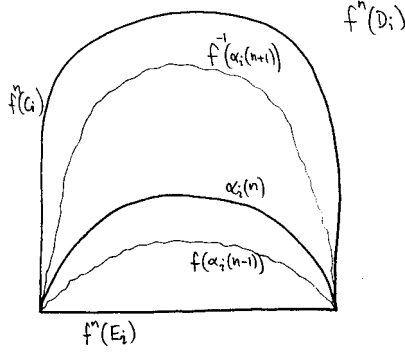

Figure 13: The  $\alpha(n)$ 's are chosen so that  $\alpha_i(n) \subset I^c(f(\alpha_i(n-1)))$  and  $\alpha_i(n) \subset I^e(f^{-1}(\alpha_i(n+1)))$ .

(iii) for  $m \leq 0$ ,  $\{\beta_i(m); i \in \underline{L}\}$  is a  $(\varepsilon_{|m|}, e)$ -collection compatible with

$$\begin{aligned} & \{(f^k(D_i), \gamma_i(k)); i \in \underline{L}, m+1 \leq k \leq -m+1\} \\ & \cup \{(f^m(D_i), f^{-1}(\gamma_i(m+1))); i \in \underline{L}\}. \quad \square \end{aligned}$$

The corollary below is proved in the same way as Corollary 3.19 (see figure 15.)

**Corollary 3.21** *With the notation of Proposition 3.20, for every  $n \in \mathbb{Z}$ ,  $\gamma_i(n) \subset I^c(f(\beta_i(n-1)))$  and  $\beta_i(n) \subset I^e(f^{-1}(\gamma_i(n+1)))$ .  $\square$*

The next proposition creates the sets in whose union will lie the support of the isotopy we will construct to prove the main theorem.

**Proposition 3.22** *Let  $\{\alpha_i(n)\}$ ,  $\{\beta_i(n)\}$  and  $\{\gamma_i(n)\}$  be as in Propositions 3.18 and 3.20. Then for every  $n \in \mathbb{Z}$  and  $i \in \underline{L}$ ,  $\overline{f^{-1}(\beta_i(n+1)) \cup \gamma_i(n)}$  is a Jordan curve bounding a Jordan domain  $\mathcal{V}_i(n)$  such that*

$$\mathcal{V}_i(n) \supset f^{-1}(\alpha_i(n+1)) \cup \alpha_i(n).$$

Moreover,

$$\mathcal{V}_i(n) = I^c(\gamma_i(n)) \cap I^e(f^{-1}(\beta_i(n+1))).$$

PROOF: The proof is an easy exercise using (i) of Proposition 3.20, Corollary 3.21 and Proposition 3.3 (see figure 16.)  $\square$



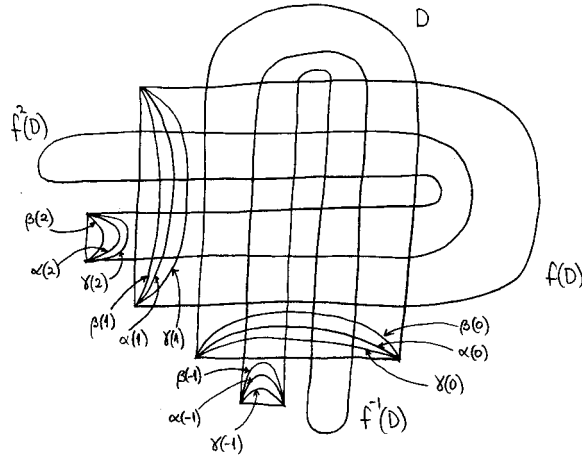

Figure 14: The first few  $\gamma(n)$ 's and  $\beta(n)$ 's for a pruning collection containing only one  $(c, e)$ -disk  $D$ .

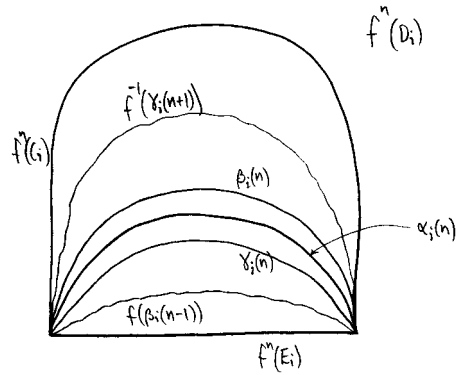

Figure 15: The  $\beta_i(n)$ 's and  $\gamma_i(n)$ 's are chosen so that  $\gamma_i(n) \subset I^c(f(\beta_i(n-1)))$  and  $\beta_i(n) \subset I^e(f^{-1}(\gamma_i(n+1)))$ .

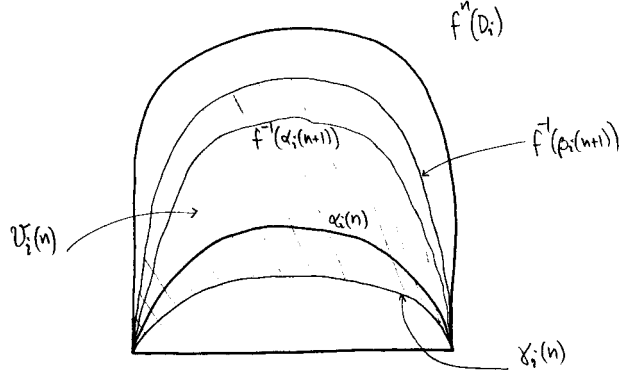

Figure 16:  $\overline{f^{-1}(\beta_i(n+1)) \cup \gamma_i(n)}$  is a Jordan curve bounding the domain  $\mathcal{V}_i(n)$ .

**Proposition 3.23** *Let  $D_1, D_2$  be  $(c, e)$ -disks,  $D_1 \not\asymp D_2$  and  $\alpha_1 \subset D_1$  and  $\alpha_2 \subset D_2$  be disjoint open cross-cuts joining vertices. Then  $\alpha_1 \cap I_2 \subset I^c(\alpha_2)$  and  $\alpha_2 \cap I_1 \subset I^e(\alpha_1)$ .*

PROOF: Since  $D_1 \not\asymp D_2$  either  $I_1 \cap I_2 = \emptyset$ , in which case both statements are clearly true, or  $D_1 \succ D_2$  and  $D_1 \neq D_2$ . If  $D_1 \succ D_2$ ,  $C_1 \cap I_2 = \emptyset$  and since  $\alpha_1 \cap \alpha_2 = \emptyset$ ,  $(\alpha_1 \cup C_1) \cap \alpha_2 = \emptyset$ . It follows, since  $\alpha_2$  is connected, that either  $\alpha_2 \subset I^c(\alpha_1)$  or  $\alpha_2 \cap I^c(\alpha_1) = \emptyset$ . We want to show that the latter is true, so we will assume  $\alpha_2 \subset I^c(\alpha_1)$  and reach a contradiction. The endpoints of  $\alpha_2$  are the same as those of  $E_2$  and since  $E_2 \cap I_1 = \emptyset$  ( $D_1 \succ D_2$ ) and  $\alpha_1 \subset I_1$ , if  $\alpha_2 \subset I^c(\alpha_1)$ , it must be the case that the endpoints of  $\alpha_2$  lie on  $C_1$ . But the endpoints of  $\alpha_2$  coincide with those of  $C_2$  and, by (ii) in the definition of  $\succ$ ,  $C_2 \subset C_1$ . We claim that  $C_1 = C_2$ , for if  $C_2$  is strictly contained in  $C_1$ , one of the endpoints of  $\alpha_2$  lies in  $\overset{\circ}{C}_1$  and since  $\alpha_2 \subset I_1 \cap I_2$ , (iii) in the definition of  $\succ$  implies that  $C_1 \subset C_2$  which is a contradiction. By Proposition 3.6 we see that  $D_1 = D_2$  which is contrary to our hypothesis that  $D_1 \not\asymp D_2$ .

This contradiction shows that  $\alpha_2 \cap I^c(\alpha_1) = \emptyset$  and since  $\alpha_2 \cap \alpha_1 = \emptyset$  by hypothesis, we have shown that  $\alpha_2 \cap I_1 \subset I^e(\alpha_1)$ . The other statement is proven analogously.  $\square$

**Corollary 3.24** *Under the hypotheses of Proposition 3.23*

$$I^c(\alpha_1) \cap I^e(\alpha_2) = \emptyset. \quad \square$$

**Proposition 3.25** *Let  $i, j \in \underline{L}$  and  $n, k \in \mathbb{Z}$ :*

(i) if  $f^k(D_j) \not\prec f^n(D_i)$  then  $f^{-1}(\alpha_j(k+1)) \cap \overline{\mathcal{V}_i(n)} = \emptyset$ , and

(ii) if  $f^k(D_j) \not\prec f^n(D_i)$  then  $\alpha_j(k) \cap \overline{\mathcal{V}_i(n)} = \emptyset$ .

PROOF: From Proposition 3.20 (i) and Proposition 3.3 it follows that  $\alpha_i(n) \subset I^e(\beta_i(n)) \cap I^c(\gamma_i(n))$ . From Proposition 3.20 it also follows that  $\beta_j(k) \cap \gamma_i(n) = \emptyset$  for any  $i, j \in \underline{L}$ ,  $k, n \in \mathbb{Z}$ . Assume  $f^k(D_j) \not\prec f^n(D_i)$ . By Corollary 3.24, we see that  $I^e(\beta_j(k)) \cap I^c(\gamma_i(n)) = \emptyset$ . Since  $\mathcal{V}_i(n) \subset I^c(\gamma_i(n))$ ,  $\alpha_j(k) \subset I^e(\beta_j(k))$  and  $I^e(\beta_j(k))$  is open we can conclude that  $\overline{\mathcal{V}_i(n)} \cap \alpha_j(k) = \emptyset$ . This proves (ii). In order to prove (i) assume  $f^k(D_j) \not\prec f^n(D_i)$ . Then  $f^{k+1}(D_j) \not\prec f^{n+1}(D_i)$  and, as above, we can conclude that  $I^e(\beta_i(n+1)) \cap I^c(\gamma_j(k+1)) = \emptyset$ . It follows that

$$I^e(f^{-1}(\beta_i(n+1))) \cap I^c(f^{-1}(\gamma_j(k+1))) = \emptyset$$

and since

$$\mathcal{V}_i(n) \subset I^e(f^{-1}(\beta_i(n+1))),$$

then

$$f^{-1}(\alpha_j(k+1)) \subset I^c(f^{-1}(\gamma_j(k+1))).$$

This latter being an open set, we see that

$$f^{-1}(\alpha_j(k+1)) \cap \overline{\mathcal{V}_i(n)} = \emptyset.$$

This completes the proof.  $\square$

**Proposition 3.26** *With the notation above:*

(i) for  $n \geq 1$  and  $-n+1 \leq k \leq n$ ,  $f^k(C_i) \cap f^n(I_j) \subset I^c(\gamma_j(n))$ ;

(ii) for  $m \leq 0$  and  $m \leq k \leq -m+1$ ,  $f^k(E_i) \cap f^m(I_j) \subset I^e(\beta_j(m))$ .

PROOF: From Proposition 3.20 we know that  $\{\gamma_j(n)\}_{j=1}^L$  is compatible with

$$\{(f^k(D_i), \beta_i(k)); i \in \underline{L}, -n+1 \leq k \leq n-1\} \cup \{(f^n(D_i), f(\beta_i(n-1))); i \in \underline{L}\}.$$

If  $f^k(C_i) \cap f^n(I_j) = \emptyset$  there is nothing to prove. Otherwise,  $f^n(D_j) \succ f^k(D_i)$  and therefore either  $[I^c(\gamma_j(n)) \cup \gamma_j(n)] \subset I^c(\beta_i(k))$  or  $[I^c(\gamma_j(n)) \cup \gamma_j(n)] \cap f^k(D_i) = \emptyset$ . Since  $f^k(C_i) \subset f^k(D_i) \cap I^c(\beta_i(k))$ , the conclusion of (i) follows.  $\square$

**Corollary 3.27** For  $k \geq 1$ ,  $f^k(C_i)$  and  $f^{-k}(E_i)$  are disjoint from  $\mathcal{V}_j(n)$  for every  $i, j \in \underline{L}$  and every  $n \in \mathbb{Z}$ .

PROOF: If  $k > n$  by the definition of pruning collection  $f^k(D_i) \not\subset f^n(D_j)$  which implies that  $f^k(C_i) \cap f^n(I_j) = \emptyset$ . Since  $\mathcal{V}_j(n) \subset f^n(I_j)$  this proves the result for  $k > n$ . If  $1 \leq k \leq n$  by Proposition 3.26,  $f^k(C_i) \cap \mathcal{V}_j(n) \subset I^e(\gamma_j(n))$  whereas by Proposition 3.22,  $\mathcal{V}_j(n) \subset I^c(\gamma_j(n))$ , which completes the proof of  $f^k(C_i) \cap \mathcal{V}_j(n) = \emptyset$  if  $k \geq 1$ ,  $j \in \underline{L}$  and  $n \in \mathbb{Z}$ .

If  $n > k$  we again have by the definition of pruning collection that  $f^n(D_j) \not\subset f^k(D_i)$ , which implies that  $f^k(E_i) \cap f^n(I_j) = \emptyset$  and thus that  $f^k(E_i) \cap \mathcal{V}_j(n) = \emptyset$ . If  $m \leq k \leq 0$ , by Proposition 3.26,  $f^k(E_i) \cap f^n(I_j) \subset I^c(\beta_j(n))$  which implies that, if  $n \leq k \leq -1$ ,

$$f^k(E_i) \cap f^n(I_j) \subset f^{-1}(I^c(\beta_j(n+1))) = I^c(f^{-1}(\beta_j(n+1))).$$

By Proposition 3.22,  $\mathcal{V}_j(n) \subset I^e(f^{-1}(\beta_j(n+1)))$  and thus  $f^k(E_i) \cap \mathcal{V}_j(n) = \emptyset$  if  $k \leq 1$ ,  $j \in \underline{L}$ ,  $n \in \mathbb{Z}$ . This completes the proof.  $\square$

## 4 Isotopies

**Definition 4.1** Let  $X, Y$  be topological spaces. By an isotopy we mean a continuous map  $H : X \times [0, 1] \rightarrow Y$  such that the “slice” map  $H_t : X \rightarrow Y$ ,  $H_t(x) = H(x, t)$  is a homeomorphism for each  $t \in [0, 1]$ . If  $f, g : X \rightarrow Y$  are homeomorphisms, we say  $f$  and  $g$  are isotopic if there exists an isotopy  $H : X \times [0, 1] \rightarrow Y$  such that  $H(x, 0) = f(x)$  and  $H(x, 1) = g(x)$  for every  $x \in X$ .

The support of an isotopy  $H$  is by definition (see the remark below) the set

$$\text{supp } H = \mathcal{C}\{x \in X; H(x, t) = H(x, 0) \forall t \in [0, 1]\}$$

where, as usual,  $\mathcal{C}$  stands for complement.

If  $f : X \rightarrow X$  is a homeomorphism we define the support of  $f$  as

$$\text{supp } f = \mathcal{C}\{x \in X; f(x) = x\}$$

REMARK: Notice that our definition of support is not the usual one in that we are not taking closures. Supports of isotopies and homeomorphisms are therefore *open* sets.

The following proposition is a straightforward exercise in point set topology and we omit the proof.

**Proposition 4.2** *Let  $H : X \times [0, 1] \rightarrow X$  be an isotopy of the identity, i.e.,  $H(x, 0) = x$  for every  $x \in X$ . If  $x \in \text{supp } H$ , then  $H(x, t)$  and  $x$  belong to the same path component of  $\text{supp } H$ .  $\square$*

REMARK: If  $X$  is locally path-connected, the path components of  $\text{supp } H$  coincide with its connected components, since  $\text{supp } H$  is open.

**Definition 4.3** *Let  $G$  be a collection of subsets of a metric space. We call  $G$  a null collection if for every  $\varepsilon > 0$  only finitely many elements of  $G$  have diameter greater than  $\varepsilon$ .*

The lemma below is true in greater generality than we state and is part of the folklore of hyperbolic geometry, geodesic laminations, etc. The proof we give is somewhat sketchy but is rather elementary.

**Lemma 4.4** *Let  $\mathbb{D}$  denote the unit disk  $\{x \in \mathbb{R}^2; \|x\| \leq 1\}$ , and  $\{\alpha_n\}_{n=1}^{\infty}$  a null collection of closed cross-cuts, disjoint except possibly at endpoints, no two  $\alpha_n$ 's sharing both endpoints. For each  $n \geq 1$ , let  $\gamma_n$  be the closed arc of circle perpendicular to  $S^1 = \{x \in \mathbb{R}^2; \|x\| = 1\}$  with the same endpoints as  $\alpha_n$ . Then there exists a homeomorphism  $\zeta : \mathbb{D} \rightarrow \mathbb{D}$  such that  $\zeta|_{S^1}$  is the identity and  $\zeta(\alpha_n) = \gamma_n$ .*

PROOF: From the hypotheses that the  $\alpha_n$ 's are interior disjoint and no two share both endpoints it follows that the cross-cuts  $\gamma_n$  are interior disjoint and the correspondence  $\alpha_n \rightarrow \gamma_n$  is one-to-one in the sense that if  $\alpha_n \neq \alpha_m$  then  $\gamma_n \neq \gamma_m$ . Moreover,  $\{\gamma_n\}_{n=1}^{\infty}$  is a null collection, since given  $\varepsilon > 0$  only finitely many pairs of endpoints of the  $\alpha_n$ 's can be more than  $\varepsilon$  apart, which implies that only finitely many  $\gamma_n$ 's have diameter greater than  $\varepsilon$ .

Let  $\psi_n : \gamma_n \rightarrow \alpha_n$  be a homeomorphism extending the identity homeomorphism between the endpoints of  $\gamma_n$  and  $\alpha_n$ , for each  $n \geq 1$ , and define the map  $\psi$  as

$$\psi = \text{id} \cup \bigcup_{n=1}^{\infty} \psi_n : S^1 \cup \bigcup_{n=1}^{\infty} \gamma_n \longrightarrow S^1 \cup \bigcup_{n=1}^{\infty} \alpha_n$$

where  $\text{id} : S^1 \rightarrow S^1$  is the identity homeomorphism.  $\psi$  is well defined since the interiors  $\overset{\circ}{\gamma}_n$  are disjoint and  $\psi_n$  is the identity at the endpoints of  $\gamma_n$ . We claim  $\psi$  is a homeomorphism. From what we have said above,  $\psi$  is clearly one-to-one and onto. All there remains to show is that  $\psi$  is continuous. Let  $\{x_k\}$  be a sequence in  $S^1 \cup \bigcup_{n=1}^{\infty} \gamma_n$  and assume  $x_k \rightarrow x$ . We want to show that  $\psi(x_k) \rightarrow \psi(x)$ . If there exists  $n$  such that all but finitely many points  $x_k$  lie in  $\gamma_n$ , then for

$k_0$  sufficiently large  $x_k \in \gamma_n$  for every  $k \geq k_0$  and since  $\gamma_n$  is closed  $x \in \gamma_n$ . It follows that for  $k \geq k_0$ ,  $\psi(x_k) = \psi_n(x_k) \rightarrow \psi_n(x) = \psi(x)$  since  $\psi_n$  is continuous. If there is no  $\gamma_n$  containing all but finitely many  $x_k$ 's, we can choose a subsequence  $x_{k_j} \in \gamma_j$  so that different points lie in different  $\gamma_j$ 's. Since  $\{\gamma_n\}$  is a null sequence,  $\text{diam } \gamma_j \rightarrow 0$  as  $j \rightarrow \infty$  and, since  $x_{k_j} \in \gamma_j$  and  $x_{k_j} \rightarrow x$ , for any sequence  $y_j \in \gamma_j$ ,  $y_j \rightarrow x$ . In particular, if  $p_j, q_j$  are the endpoints of  $\gamma_j$ ,  $p_j, q_j \rightarrow x$ . This shows that  $x \in S^1$ . Also, the cross-cuts  $\alpha_j$ , whose endpoints are  $p_j, q_j$ , are all distinct, since the  $\gamma_j$ 's are, and since  $\{\alpha_n\}$  is a null family and  $p_j, q_j \rightarrow x$ , for any sequence  $z_j \in \alpha_j$ ,  $z_j \rightarrow x$ . We then have  $\psi(x_{k_j}) = \psi_j(x_{k_j}) = z_j \in \alpha_j$  and  $z_j \rightarrow x = \psi(x)$  since  $x \in S^1$ . This shows that  $\psi$  is a homeomorphism. Assume for a moment we have shown that every component of the complement of  $S^1 \cup \bigcup_{n=1}^{\infty} \gamma_n$  in  $\mathbb{D}$  is a Jordan domain. Let  $U$  be one such and  $\partial U = J$ .  $J$  is a Jordan curve in  $S^1 \cup \bigcup_{n=1}^{\infty} \gamma_n$  and thus  $\psi(J)$  is a Jordan curve in  $S^1 \cup \bigcup_{n=1}^{\infty} \alpha_n$ . We claim that the Jordan domain  $V$  bounded by  $\psi(J)$  is a component of the complement of  $S^1 \cup \bigcup_{n=1}^{\infty} \alpha_n$  in  $\mathbb{D}$ . It is clear that  $V \subset \{x; |x| < 1\}$  so that  $V \cap S^1 = \emptyset$ . If  $V \cap \alpha_j \neq \emptyset$  for some  $\alpha_j$ , then  $\alpha_j$ , which is connected and disjoint from  $S^1 \cup \bigcup_{n \neq j} \alpha_n \supset \partial V$ , is contained in  $V$  and its endpoints in  $\partial V$ . But this implies that the endpoints of  $\gamma_j$  lie on  $J$  which in turn implies  $\gamma_j \subset \overline{U}$ . Since we assumed  $U$  to be in the complement of  $S^1 \cup \bigcup_{n=1}^{\infty} \gamma_n$ ,  $\gamma_j \subset J = \partial U$ . This would then contradict the hypothesis that no two  $\alpha_n$ 's shared both endpoints. This shows that if  $U$  is a component of the complement of  $S^1 \cup \bigcup_{n=1}^{\infty} \gamma_n$  in  $\mathbb{D}$  whose boundary is a Jordan curve  $J$ ,  $\psi(J)$  is a Jordan curve in  $S^1 \cup \bigcup_{n=1}^{\infty} \alpha_n$  bounding a component  $V$  of the complement of  $S^1 \cup \bigcup_{n=1}^{\infty} \alpha_n$  in  $\mathbb{D}$ . So if every component  $U$  of the complement of  $S^1 \cup \bigcup_{n=1}^{\infty} \gamma_n$  in  $\mathbb{D}$  is a Jordan domain we can use Theorem 1.7 to extend  $\psi$  to a homeomorphism  $\tilde{\psi} : \mathbb{D} \rightarrow \mathbb{D}$  and  $\zeta = \tilde{\psi}^{-1}$  will satisfy the conclusions of the lemma.

In order to see that the components  $U$  of  $\mathbb{D} \setminus \left[ S^1 \cup \bigcup_{n=1}^{\infty} \gamma_n \right]$  are Jordan domains let  $\gamma_n$  be a cross-cut such that  $\gamma_n \subset \partial U$ . Such a  $\gamma_n$  must exist unless  $\{\gamma_n\} = \emptyset$  in which case the statement is trivial. By a conformal mapping, map  $\mathbb{D}$  onto the upper half plane  $\mathbb{H}$  so that  $\gamma_n$  maps onto  $S^1 \cap \mathbb{H}$  and  $U$  maps onto  $U' \subset \{x; |x| < 1\} \cap \mathbb{H}$ . It is now not hard to see that  $\partial U' \setminus S^1$  is the graph of a continuous function  $g : (-1, 1) \rightarrow [0, 1)$  such that  $|g(x)| < \sqrt{1-x^2}$  for every  $x \in (-1, 1)$ . This proves that  $\partial U'$  is a Jordan curve and therefore so is  $\partial U$  and completes the proof of the lemma.  $\square$

**Corollary 4.5** *Let  $J$  be a Jordan curve and  $\{\alpha_n\}_{n=1}^\infty$  and  $\{\beta_n\}_{n=1}^\infty$  two null collections of interior disjoint cross-cuts in  $D$ , the closed disk bounded by  $J$ . Assume that no two elements of each collection share both endpoints and that the endpoints of  $\alpha_i$  and  $\beta_i$  coincide. Then there exists a homeomorphism  $\zeta : D \rightarrow D$  such that  $\zeta|_J$  is the identity,  $\zeta(\alpha_n) = \beta_n$  and  $\zeta$  is isotopic to the identity through an isotopy with support in  $I$ , the interior of  $D$ .*

PROOF: Let  $f : D \rightarrow \mathbb{D}$  a homeomorphism and  $\zeta_\alpha : \mathbb{D} \rightarrow \mathbb{D}$  and  $\zeta_\beta : \mathbb{D} \rightarrow \mathbb{D}$  homeomorphisms “straightening”  $\{f(\alpha_n)\}$  and  $\{f(\beta_n)\}$ , which exist by Lemma 4.4. Set  $\zeta = \zeta_\beta^{-1} \circ \zeta_\alpha$ . It is not hard to check that  $\zeta|_J = \text{id}$  and  $\zeta(\alpha_n) = \beta_n$ . That  $\zeta$  is isotopic to the identity is a consequence of Theorem 1.8.  $\square$

**Corollary 4.6** *Let  $J$  be a Jordan curve and  $\alpha, \beta$  cross-cuts in  $D$  having the same endpoints. Then there exists an isotopy of the identity taking  $\alpha$  to  $\beta$  with support in  $I$ .*

PROOF: The collection  $\{\alpha\}$  with a single element is a null collection so it is possible to apply Lemma 4.4 and Corollary 4.5.  $\square$

NOTATION: Let  $D_1, D_2$  be closed disks,  $D_1 \subset D_2$  and  $D_1, D_2|_L$ , where  $L \subset \partial D_1 \cap \partial D_2$  is an arc. If  $D_1 \setminus L \subset I_2$ , the interior of  $D_2$ , we will write  $D_1 \subset D_2|_L$ .

**Lemma 4.7** *Let  $\psi : D \rightarrow D$  be a homeomorphism onto its image so that  $\psi(D) \subset D|_{\psi(L)}$ , where  $L$  is a closed arc,  $\psi(L) \subset L$  and  $p \in L$  is a fixed point such that  $\psi^n(x) \rightarrow p$  for every  $x \in L$ . Then there exists an isotopy  $h : D \times [0, 1] \rightarrow D$  of the identity such that  $h|_{\partial D} = \text{id}$  and if  $\zeta(\cdot) = h(\cdot, 1)$ , then  $(\psi \circ \zeta)^n(x) \rightarrow p$  for every  $x \in D$ .*

PROOF: We will construct a null collection  $\{\alpha_n\}_{n=1}^\infty$  of disjoint open cross-cuts in  $I$  with the following properties:

- (i)  $\alpha_n$  has the same endpoints as  $\psi^n(L)$ ;
- (ii) if  $I_{n-1}$  is the Jordan domain bounded by  $\alpha_{n-1} \cup \psi^{n-1}(L)$ ,  $\alpha_n$  is a cross-cut in  $I_{n-1} \cap \psi(I_{n-1})$ , for  $n \geq 2$ ;
- (iii)  $\alpha_n \subset V_n^\perp(\psi^n(L))$ .

Set  $\alpha_1 = \psi(\partial D \setminus L)$  and  $D_1 = \psi(D)$ . Notice that  $D_1 \subset D|_{\psi(L)}$  implies  $\psi(D_1) \subset D_1|_{\psi^2(L)}$ . By Proposition 2.13, it is possible to find  $\alpha_2 \subset \psi(I_1) \cap I_1 = \psi(I_1)$ , an open cross-cut joining the endpoints of  $\psi^2(L)$  such that  $\alpha_2 \subset V_{\frac{1}{2}}(\psi^2(L))$ .

Assume we have constructed  $\alpha_1, \alpha_2, \dots, \alpha_n$  satisfying (i), (ii) and (iii) above. Since  $\alpha_n \subset \psi(I_{n-1}) \cap I_{n-1}$ , and  $\alpha_n$  has the same endpoints as  $\psi^n(L)$ ,  $D_n \subset \psi(D_{n-1})|_{\psi^n(L)}$  and  $D_n \subset D_{n-1}|_{\psi^n(L)}$ . This latter implies that  $\psi(D_n) \subset \psi(D_{n-1})|_{\psi^{n+1}(L)}$  and since  $\psi^{n+1}(L) \subset \psi^n(L)$ , by Proposition 2.9, it follows that  $D_n, \psi(D_n)|_{\psi^{n+1}(L)}$ . By Proposition 2.13, there exists  $\alpha_{n+1} \subset I_n \cap \psi(I_n)$  an open cross-cut with the same endpoints as  $\psi^{n+1}(L)$  such that  $\alpha_{n+1} \subset V_{\frac{1}{n+1}}(\psi^{n+1}(L))$ . By induction, we construct the collection  $\{\alpha_n\}_{n=1}^{\infty}$ . That  $\{\alpha_n\}_{n=1}^{\infty}$  is a null collection follows from the fact that  $\alpha_n \subset V_{\frac{1}{n}}(\psi^n(L))$  and  $\text{diam } \psi^n(L) \rightarrow 0$ . That the  $\alpha_n$ 's are disjoint is clear since  $\alpha_n \subset I_{n-1}$  for every  $n \geq 1$ . Notice also that no two  $\alpha_n$ 's share both endpoints. This is so because the endpoints of  $\alpha_n$  are the same as those of  $\psi^n(L)$  and if  $\psi^n(L)$  and  $\psi^m(L)$  shared both endpoints,  $L$  would contain more than one fixed point.

Let  $\beta_n = \psi^{-1}(\alpha_{n+1})$ . The collection  $\{\beta_n\}_{n=1}^{\infty}$  is clearly a null collection of disjoint open cross-cuts no two of which share both endpoints. Also, for each  $n \geq 1$ ,  $\alpha_n$  and  $\beta_n$  have the same endpoints. By Corollary 4.5 there exists an isotopy of the identity  $h : D \times [0, 1] \rightarrow D$  such that if  $\zeta(\cdot) = h(\cdot, 1)$ ,  $\zeta(\alpha_n) = \beta_n$ . Then  $\psi \circ \zeta(\alpha_n) = \psi(\beta_n) = \alpha_{n+1}$  and since  $\psi(\psi^n(L)) = \psi^{n+1}(L)$  we see that  $\psi \circ \zeta(D_n) = D_{n+1}$ . But  $\text{diam } D_n \rightarrow 0$  as  $n \rightarrow \infty$  and therefore it follows that  $(\psi \circ \zeta)^n(x) \rightarrow p$ ,  $\forall x \in D$  as  $n \rightarrow \infty$  as we wanted.  $\square$

**Corollary 4.8** *For  $i = 1, \dots, n$  let  $D_i$  be closed disks with disjoint interiors and  $L_i \subset \partial D_i$  a closed arc. Let  $\psi : \pi \rightarrow \pi$  be a homeomorphism of the plane such that  $\psi(L_i) \subset L_{i+1}$  and  $\psi(D_i) \subset D_{i+1}|_{\psi(L_i)}$ , where we let the indices “wrap around”, i.e., we set  $n+1$  to be 1. Assume  $\psi^n|_{D_1} : (D_1, L_1) \rightarrow (D_1, L_1)$  satisfies the hypotheses of Lemma 4.7. Then there exists an isotopy  $h : \pi \times [0, 1] \rightarrow \pi$  of the identity such that  $\text{supp } h \subset D_1$  and if  $\zeta(\cdot) = h(\cdot, 1)$ ,  $(\psi \circ \zeta)^{kn}(x) \rightarrow p$  as  $k \rightarrow \infty$  for every  $x \in D_1$  where  $p \in L_1$  is the fixed point of  $\psi^n|_{L_1}$ .*

PROOF: The proof is straightforward using Lemma 4.7 and we omit the details.  $\square$

## 5 The Proof of the Main Theorem

In what follows  $f : \pi \rightarrow \pi$  will be a uniformly continuous homeomorphism of the plane and  $\{D_i\}_{i=1}^L$  a pruning collection for  $f$ . As we pointed out before, we may and will assume that the subscripts



reflect the partial order  $\geq$  in  $\{D_i\}_{i=1}^L$ , in the sense that, if  $i > j$  then  $D_i \not\leq D_j$ . In particular, if  $i > j$  then  $D_i \not\leq D_j$ .

**Definition 5.1** For each  $i \in L$  we define four numbers  $n(i)$ ,  $N(i)$ ,  $m(i)$ ,  $M(i) \in \mathbb{Z} \cup \{\pm\infty\}$  as follows:

- (i)  $n(i)$  is the smallest integer  $\geq 1$  such that  $f^{n(i)}(D_i), f(D_j)|_{f^{n(i)}(C_i)}$  for some  $j \in \underline{L}$  or  $n(i) = \infty$  if  $f^k(D_i), f(D_j) \not\chi_{f^k(C_i)}$  for every  $k \geq 1$  and  $j \in \underline{L}$ ;
- (ii)  $N(i) = \left\lceil \frac{n(i)}{2} \right\rceil$ , i.e., the smallest integer greater than or equal to  $\frac{n(i)}{2}$ , if  $n(i) < \infty$  or  $N(i) = \infty$  if  $n(i) = \infty$ ;
- (iii)  $m(i)$  is the largest integer  $\leq 0$  such that  $f^{m(i)}(D_i), D_j|_{f^{m(i)}(E_i)}$  for some  $j \in \underline{L}$  or  $m(i) = -\infty$  if  $f^k(D_i), D_j \not\chi_{f^k(E_i)}$  for every  $k \leq 0$  and  $j \in \underline{L}$ ;
- (iv)  $M(i) = \left\lceil \frac{m(i)}{2} \right\rceil$  if  $m(i) > -\infty$  or  $M(i) = -\infty$  if  $m(i) = -\infty$ .

The following proposition is a straightforward consequence of the definitions and we omit the proof.

**Proposition 5.2** If  $n(i)$ ,  $N(i)$ ,  $m(i)$  and  $M(i)$  are finite the following holds for each  $i \in \underline{L}$ :

- (i)  $n(i) = 2N(i) - \delta$  and  $m(i) = 2M(i) - \delta'$  where  $\delta, \delta' = 0$  or  $1$ ;
- (ii)  $f^{N(i)}(D_i), f^{-N(i)+\delta+1}(D_j)|_{f^{N(i)}(C_i)}$  for some  $j \in \underline{L}$  but for  $-N(i) + \delta + 2 \leq k \leq N(i) - 1$ ,

$$f^{N(i)}(D_i), f^k(D_j) \not\chi_{f^{N(i)}(C_i)}$$

for any  $j \in \underline{L}$ ;

- (iii) for  $1 \leq n < N(i)$ ,  $-n + 1 \leq k \leq n - 1$ ,  $f^n(D_i), f^k(D_j) \not\chi_{f^n(C_i)}$  for any  $j \in \underline{L}$ ;
- (iv)  $f^{M(i)}(D_i), f^{-M(i)+\delta'}(D_j)|_{f^{M(i)}(E_i)}$  for some  $j \in \underline{L}$  but for  $M(i) + 1 \leq k \leq -M(i) + \delta' + 1$ ,

$$f^{M(i)}(D_i), f^k(D_j) \not\chi_{f^{M(i)}(E_i)}$$

for any  $j \in \underline{L}$ ;

- (v) for  $M(i) < m \leq 0$  and  $m + 1 \leq k \leq -m + 1$ ,  $f^m(D_i), f^k(D_j) \not\chi_{f^m(E_i)}$  for any  $j \in \underline{L}$ .  $\square$

Recall that we defined  $c$ - and  $e$ -equivalence relations in a collection  $\{D_i\}_{i=1}^L$  of  $(c, e)$ -disks and in Proposition 3.15 proved that the equivalence classes have distinguished representatives. The following proposition is again an easy consequence of the definitions.

**Proposition 5.3** *For each  $i \in \underline{L}$ ,  $n(i) > 1$  if and only if  $D_i$  is the distinguished representative in its  $c$ -equivalence class in  $\{D_i\}_{i=1}^L$ . Likewise,  $m(i) < 0$  if and only if  $D_i$  is the distinguished representative in its  $e$ -equivalence class in  $\{D_i\}_{i=1}^L$ .  $\square$*

We now start the construction of the isotopy for the proof of the main theorem. If the pruning collection contains only one  $(c, e)$ -disk  $D_1$  and  $N(1) = \infty$  and  $M(1) = -\infty$ , most of what is presented from here to the end of this section is very much simplified. We suggest that the reader concentrate on this case upon a first reading.

Recall that  $\mathcal{V}_i(n) \subset f^n(I_i)$  is a Jordan domain containing  $\alpha_i(n)$  and  $f^{-1}(\alpha_i(n+1))$  as cross-cuts with the same endpoints. Using Corollary 3.21 construct, for each  $i \in \underline{L}$  and  $M(i) \leq n < N(i)$  an isotopy  $k_{i,n} : \pi \times [0, 1] \rightarrow \pi$  of the identity such that  $\text{supp } k_{i,n} \subset \mathcal{V}_i(n)$  and  $k_{i,n}(\alpha_i(n), 1) = f^{-1}(\alpha_i(n+1))$ . If  $n < M(i)$  or  $n \geq N(i)$  we let  $k_{i,n} \equiv \text{identity}$ . Set  $\zeta_{i,n}(\cdot) = k_{i,n}(\cdot, 1)$ . For  $n \in \mathbb{Z}$  define

$$k_n(x, t) = \begin{cases} k_{1,n}(x, Lt), & t \in \left[0, \frac{1}{L}\right] \\ \zeta_{1,n}(k_{2,n}(x, Lt - 1)), & t \in \left[\frac{1}{L}, \frac{2}{L}\right] \\ \zeta_{1,n} \circ \zeta_{2,n}(k_{3,n}(x, Lt - 2)), & t \in \left[\frac{2}{L}, \frac{3}{L}\right] \\ \vdots & \vdots \\ \zeta_{1,n} \circ \zeta_{2,n} \circ \dots \circ \zeta_{L-1,n}(k_{L,n}(x, Lt - L + 1)), & t \in \left[\frac{L-1}{L}, 1\right] \end{cases}$$

and let  $\zeta_n(\cdot) = k_n(\cdot, 1)$ . Now let  $r_0 = k_0$  and for  $n \geq 1$

$$r_n(x, t) = \begin{cases} k_{-n}(x, 2t), & t \in \left[0, \frac{1}{2}\right] \\ \zeta_{-n}(k_n(x, 2t - 1)), & t \in \left[\frac{1}{2}, 1\right] \end{cases}$$

and set  $\rho_n(\cdot) = r_n(\cdot, 1)$  for  $n \geq 0$ .

Recall that the locus  $\overline{P} = \bigcup_{i=1}^L D_i$  of a pruning collection  $\{D_i\}_{i=1}^L$  was called a pruning front. We

will denote the union of the interiors  $\bigcup_{i=1}^L I_i$  by  $P$ .

**Proposition 5.4** *The isotopies  $r_n$  just defined have the following properties:*

- (i)  $\text{supp } r_n \subset [f^n(P) \cup f^{-n}(P)] \setminus \bigcup_{-n+1}^{n-1} f^k(\overline{P})$  for every  $n \geq 0$  so that if  $n \neq m$ ,  $\text{supp } r_n \cap \text{supp } r_m = \emptyset$ ;
- (ii) since  $f$  is uniformly continuous, the diameters of the connected components of  $\text{supp } r_n$  converge to 0 as  $n \rightarrow \infty$ ;
- (iii) for each  $i \in \underline{L}$ , if  $n < N(i)$ ,  $\rho_n(\alpha_i(n)) = f^{-1}(\alpha_i(n+1))$  and if  $-n \geq M(i)$ ,  $\rho_n(\alpha_i(-n)) = f^{-1}(\alpha_i(-n+1))$ .

PROOF: From the definition of  $k_n$  it is clear that for  $n \in \mathbb{Z}$ ,

$$\text{supp } k_n \subset \bigcup \{\mathcal{V}_i(n); M(i) \leq n < N(i)\}$$

so that for  $n \geq 0$

$$\text{supp } r_n \subset \bigcup \{\mathcal{V}_i(n); 1 \leq n < N(i)\} \cup \bigcup \{\mathcal{V}_i(-n); M(i) \leq -n \leq 0\}$$

and since  $\mathcal{V}_i(n) \subset f^n(I_i)$ , it is clear that

$$\text{supp } r_n \subset f^n(P) \cup f^{-n}(P) = \bigcup_{i=1}^L f^n(I_i) \cup \bigcup_{i=1}^L f^{-n}(I_i).$$

There is nothing more to prove for  $n = 0$  (recall that  $\bigcup_1^{-1} f^k(P) = \emptyset$ , by our convention) and we may assume that  $n \geq 1$  (see figure 17.)

If  $1 \leq n < N(i)$ , it follows from Proposition 5.2 that

$$f^n(D_i), f^k(D_j) \not\ll_{f^n(C_i)}$$

for any  $j \in \underline{L}$  and  $-n+1 \leq k \leq n-1$ . Since  $\{\gamma_i(n)\}_{i=1}^L$  is a  $(\varepsilon_n, c)$ -collection compatible with

$$\{(f^k(D_j), \beta_j(k)) : j \in \underline{L}, -n+1 \leq k \leq n-1\},$$

by Proposition 3.20, we must have  $[I^c(\gamma_i(n)) \cup \gamma_j(n)] \cap f^k(D_j) = \emptyset$  for every  $j \in \underline{L}$  and  $-n+1 \leq k \leq n-1$ . But  $\mathcal{V}_i(n) \subset I^c(\gamma_i(n))$  by Proposition 3.22 and taking the union over  $j \in \underline{L}$  and  $-n+1 \leq k \leq n-1$  we see that

$$\mathcal{V}_i(n) \cap \bigcup_{-n+1}^{n-1} f^k(\overline{P}) = \emptyset$$

from which it follows that

$$\bigcup \{ \mathcal{V}_i(n); 1 \leq n < N(i) \} \cap \bigcup_{-n+1}^{n-1} f^k(\overline{P}) = \emptyset .$$

If  $M(i) < m \leq 0$ , it follows from Proposition 5.2 that

$$f^m(D_i), f^k(D_j) \not\ll_{f^m(E_i)}$$

for any  $j \in \underline{L}$  and  $m+1 \leq k \leq -m+1$ . Again by Proposition 3.20  $\{\beta_i(m)\}_{i=1}^L$  is a  $(\varepsilon_{|m|}, e)$ -collection compatible with

$$\{(f^k(D_j), \beta_j(k)); j \in \underline{L}, m+1 \leq k \leq -m+1\},$$

which implies that  $[I^e(\beta_i(m)) \cup \beta_i(m)] \cap f^k(D_j) = \emptyset$  for every  $j \in \underline{L}$  and  $m+1 \leq k \leq -m+1$ , and thus that  $[I^e(f^{-1}(\beta_i(m))) \cup f^{-1}(\beta_i(m))] \cap f^k(D_j) = \emptyset$  for every  $j \in \underline{L}$  and  $m \leq k \leq -m$ . Letting  $m = -n+1$  and noticing that  $\mathcal{V}_i(-n) \subset I^e(f^{-1}(\beta_i(-n+1)))$ , by Proposition 3.22, what we have just seen implies that for  $M(i) \leq -n < 0$

$$\mathcal{V}_i(-n) \cap \bigcup_{-n+1}^{n-1} f^k(\overline{P}) = \emptyset$$

from which it follows that

$$\bigcup \{ \mathcal{V}_i(-n); M(i) \leq -n < 0 \} \cap \bigcup_{-m+1}^{n-1} f^k(\overline{P}) = \emptyset .$$

This finishes the proof of (i).

In order to prove (ii) notice that  $\text{supp } r_n \subset \bigcup_{i=1}^L \{ \mathcal{V}_i(n) \cup \mathcal{V}_i(-n) \}$  and from Propositions 3.20 and 3.22, for  $n \geq 1$ ,  $\mathcal{V}_i(n) \subset I^c(\gamma_i(n)) \subset V_{\varepsilon_n}(f^n(C_i))$  and

$$\mathcal{V}_i(-n) \subset I^e(f^{-1}(\beta_i(-n+1))) = f^{-1}(I^e(\beta_i(-n+1))) \subset f^{-1}(V_{\varepsilon_{n-1}}(f^{-n+1}(E_i))).$$

From the  $(c, e)$  dynamic assumption,  $\text{diam } f^n(C_i) \rightarrow 0$  as  $n \rightarrow \infty$  and  $\text{diam } f^m(E_i) \rightarrow 0$  as  $m \rightarrow -\infty$ . Since  $\varepsilon_n \rightarrow 0$ , it is clear that  $\text{diam } \mathcal{V}_i(n) \rightarrow 0$ , as  $n \rightarrow \infty$  and from the uniform continuity of  $f$  we can also conclude that  $\text{diam } \mathcal{V}_i(-n) \rightarrow 0$  as  $n \rightarrow \infty$ . It is now easy to see that

the connected components of  $\bigcup_{i=1}^L \{\mathcal{V}_i(n) \cup \mathcal{V}_i(-n)\}$  have diameters converging to zero as  $n \rightarrow \infty$ . This proves (ii).

Let us now look at (iii). From the way we indexed the pruning collection, if  $i > j$ ,  $D_i \not\prec D_j$  which implies  $f^n(D_i) \not\prec f^n(D_j)$  for any  $n \in \mathbb{Z}$ . From Proposition 3.25 it follows that  $f^{-1}(\alpha_i(n+1)) \cap \mathcal{V}_j(n) = \emptyset$ . Similarly, if  $l > i$  the same proposition implies that  $\alpha_i(n) \cap \mathcal{V}_l(n) = \emptyset$ . Since each  $k_{i,n}$  is an isotopy of the identity with support contained in  $\mathcal{V}_i(n)$ , and  $\zeta_{i,n}(\cdot) = k_{i,n}(\cdot, 1)$ , we have  $\text{supp } \zeta_{i,n} \subset \mathcal{V}_i(n)$  and, from what we said above, we see that if  $j < i$ ,  $\zeta_{j,n}(f^{-1}(\alpha_i(n+1))) = f^{-1}(\alpha_i(n+1))$  and that if  $l > i$ ,  $\zeta_{l,n}(\alpha_i(n)) = \alpha_i(n)$ . Thus, for any  $M(i) \leq n < N(i)$

$$\begin{aligned} \zeta_n(\alpha_i(n)) &= \zeta_{1,n} \circ \dots \circ \zeta_{i,n} \circ \dots \circ \zeta_{L,n}(\alpha_i(n)) \\ &= \zeta_{1,n} \circ \dots \circ \zeta_{i,n}(\alpha_i(n)) \\ &= \zeta_{1,n} \circ \dots \circ \zeta_{i-1,n}(f^{-1}(\alpha_i(n+1))) \\ &= f^{-1}(\alpha_i(n+1)). \end{aligned}$$

From the definition of pruning collections,  $f^{-n}(D_i) \not\prec f^{-n}(D_j)$  for any  $n \geq 1$  and any  $i, j \in \underline{L}$  and, by Proposition 3.25, it follows that  $f^{-1}(\alpha_i(n+1)) \cap \mathcal{V}_j(-n) = \emptyset$  and  $\mathcal{V}_i(n) \cap \alpha_j(-n) = \emptyset$ . Thus we can conclude that for any  $i \in \underline{L}$ ,  $f^{-1}(\alpha_i(n+1)) \cap \text{supp } \zeta_{-n} = \emptyset$  and that  $\alpha_i(-n) \cap \text{supp } \zeta_n = \emptyset$ , for  $n \geq 1$ . Therefore if  $1 \leq n < N(i)$ ,

$$\begin{aligned} \rho_n(\alpha_i(n)) &= \zeta_{-n} \circ \zeta_n(\alpha_i(n)) \\ &= \zeta_{-n}(f^{-1}(\alpha_i(n+1))) \\ &= f^{-1}(\alpha_i(n+1)) \end{aligned}$$

and if  $M(i) \leq -n \leq -1$ ,

$$\begin{aligned} \rho_n(\alpha_i(-n)) &= \zeta_{-n} \circ \zeta_n(\alpha_i(-n)) \\ &= \zeta_{-n}(\alpha_i(-n)) \\ &= f^{-1}(\alpha_i(-n+1)). \end{aligned}$$

This completes the proof since, for  $n = 0$ ,  $\rho_0 = \zeta_0$  and this case had already been taken care of.  $\square$

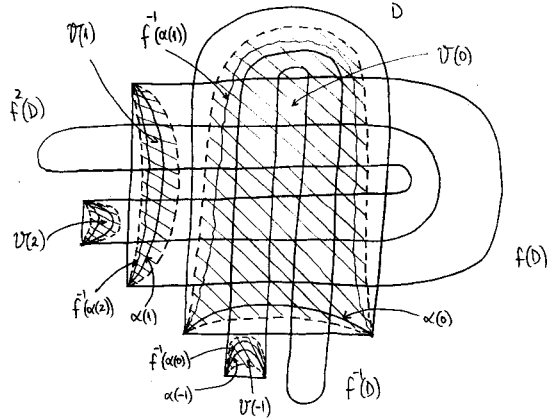

Figure 17: The first few  $\mathcal{V}(n)$ 's for a pruning collection with only one  $(c, e)$ -disk  $D$ .

**Corollary 5.5** *The sequence  $R_n = \bigcup_{i=0}^n r_n$  is a Cauchy sequence in the uniform topology and converges to an isotopy  $R : \pi \times [0, 1] \rightarrow \pi$ . If we set  $\rho(\cdot) = R(\cdot, 1)$ , for each  $i \in \underline{L}$  and  $M(i) \leq n < N(i)$ ,  $\rho(\alpha_i(n)) = f^{-1}(\alpha_i(n+1))$ . Moreover  $\text{supp } R \subset \bigcup \{\mathcal{V}_i(n); i \in \underline{L}, M(i) \leq n < N(i)\}$ .*

PROOF: Given  $\varepsilon > 0$ , by Proposition 5.4, there exists  $K$  large enough so that all the connected components of  $\text{supp } r_m$  have diameter smaller than  $\varepsilon$  if  $m \geq K$ . Let  $n > m \geq K$ . We then have

$$\begin{aligned}
 d(R_m, R_n) &= \sup_{(x,t)} d(R_m(x,t), R_n(x,t)) \\
 &= \sup_{(x,t)} d(R_m(x,t), [R_m \cup \bigcup_{m+1}^n r_i](x,t)) \\
 &= \sup_{(x,t)} d(x, \bigcup_{m+1}^n r_i(x,t)) \\
 &< \varepsilon
 \end{aligned}$$

where the last inequality is a consequence of Proposition 4.2. This shows that  $R_n$  is a Cauchy sequence. The remaining statements are readily proven and we leave them to the reader.  $\square$

**Proposition 5.6** *Let  $R$  and  $\rho$  be as in Corollary 5.5. Then for each  $i \in \underline{L}$  we have:*

(i)  $\rho(D^c(\alpha_i(n))) = D^c(f^{-1}(\alpha_i(n+1)))$  for  $1 \leq n < N(i)$  and

(ii)  $\rho(D^e(\alpha_i(m))) = D^e(f^{-1}(\alpha_i(m+1)))$  for  $M(i) \leq m < 0$ .

PROOF: Notice that  $\text{supp } R \subset \bigcup\{\mathcal{V}_i(n); i \in \underline{L}, M(i) \leq n < N(i)\}$ . By Corollary 3.27, for  $n \geq 1$ ,  $f^n(C_i) \cap \text{supp } R = \emptyset$  and by Corollary 5.5, if  $1 \leq n < N(i)$ ,  $\rho(\alpha_i(n)) = f^{-1}(\alpha_i(n+1))$ . Therefore

$$\begin{aligned} \rho(f^n(C_i) \cup \alpha_i(n)) &= \rho(f^n(C_i)) \cup \rho(\alpha_i(n)) \\ &= f^n(C_i) \cup f^{-1}(\alpha_i(n+1)) \end{aligned}$$

But

$$f^n(C_i) \cup \alpha_i(n) = \partial D^c(\alpha_i(n))$$

and

$$f^n(C_i) \cup f^{-1}(\alpha_i(n+1)) = \partial D^c(f^{-1}(\alpha_i(n+1)))$$

This completes the proof of (i). (ii) is proven analogously.  $\square$

**Definition 5.7** For each  $n \geq 0$ , let  $\psi_n = f \circ \rho_n$ ,  $\Psi_n = \bigcup_{i=0}^n \psi_i$  and  $\Psi = f \circ \rho$ , i.e.,  $\psi_n(\cdot) = f \circ r_n(\cdot, 1)$ ,  $\Psi_n(\cdot) = f \circ R_n(\cdot, 1)$  and  $\Psi(\cdot) = f \circ R(\cdot, 1)$ .

Recall that if  $\xi : X \rightarrow X$  is a homeomorphism we defined

$$\text{supp } \xi = \mathcal{C}\{x \in X; \xi(x) = x\}.$$

**Lemma 5.8** Let  $\xi, \eta : X \rightarrow X$  be homeomorphisms so that  $\text{supp } \xi \subset A$  and  $\text{supp } \eta \subset B$ . Then  $A \cup B = A \cup \xi \circ \eta(B)$ .

PROOF: First notice that if  $\text{supp } \xi \subset A$  then  $\xi(A) = A$  since  $\xi(\mathcal{C}A) = \mathcal{C}A$  and  $\xi$  is a homeomorphism. Therefore, since  $\text{supp } \xi \circ \eta \subset A \cup B$  we have

$$A \cup B = \xi \circ \eta(A \cup B) = \xi(A) \cup (B) = A \cup \xi(B) = A \cup \xi \circ \eta(B) \quad \square$$

**Proposition 5.9** For  $n \geq 0$ ,

(i)  $f^n(P) \cup f^{-n}(P) = \rho_n(f^n(P)) \cup f^{-n}(P)$ ;

(ii)  $f^n(P) \cup f^{-n}(P) = f^n(P) \cup \rho_n^{-1}(f^{-n}(P))$ .

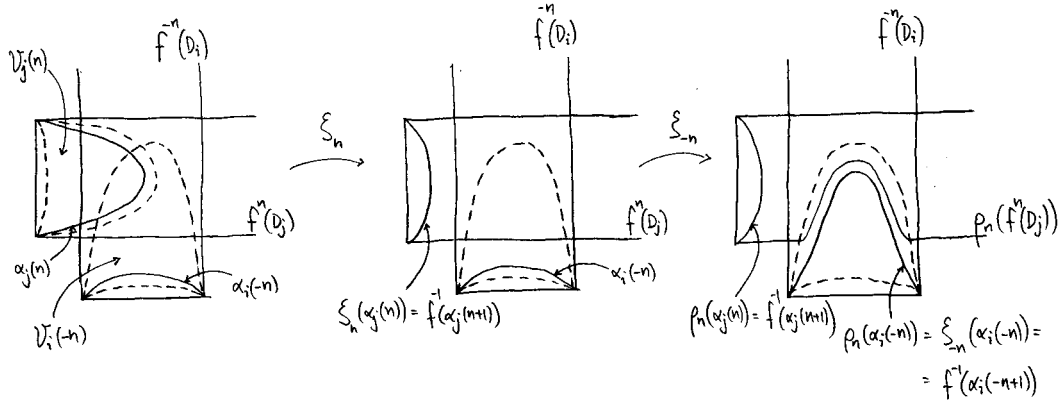

Figure 18: The homeomorphism  $\rho_n$ .

PROOF: For  $n = 0$ ,  $\text{supp } \rho_0 \subset P$  and the result follows. For  $n \geq 1$ ,  $\rho_n = \zeta_{-n} \circ \zeta_n$  and  $\text{supp } \zeta_{-n} \subset f^{-n}(P)$  and  $\text{supp } \zeta_n \subset f^n(P)$ . The results now follow as easy applications of Lemma 5.8 (see figure 18.)  $\square$

The following corollary is immediate from the definition of  $\psi_n$ .

**Corollary 5.10** For  $n \geq 1$ ,

- (i)  $f^{n+1}(P) \cup f^{-n+1}(P) = \psi_n(f^n(P)) \cup f^{-n+1}(P)$ ;
- (ii)  $f^n(P) \cup f^{-n}(P) = f^n(P) \cup \psi_n^{-1}(f^{-n+1}(P))$ .  $\square$

We now state and prove an important technical proposition to be used later. We will use the following

**Definition 5.11** Let  $P(0) = P$  and define inductively  $P(n) = \Psi_{n-1}(P(n-1))$  and  $P(-n) = \Psi_n^{-1}(P(-n+1))$ , for every  $n \geq 1$ .

**Proposition 5.12** With the notation above  $P(1) = f(P)$  and

- (i) for  $n \geq 1$ ,  $\bigcup_{-n+1}^{n-1} f^k(P) = \bigcup_{-n+1}^{n-1} P(k)$ ;
- (ii) for  $n \geq 2$ ,  $\bigcup_{-n+2}^n f^k(P) = \bigcup_{-n+2}^n P(k)$ .



PROOF: We will use induction on  $n$ . For  $n = 1$ , (i) states that  $P = P(0)$ , which is just the definition, whereas  $P(1) = \Psi_0(P) = \psi_0(P) = f\rho_0(P)$  and, since  $\text{supp } \rho_0 \subset P$ ,  $\rho_0(P) = P$ , which shows that  $P(1) = f(P)$  (see figure 19.)

We now show that  $\bigcup_0^2 f^k(P) = \bigcup_0^2 P(k)$ , but before we start, let us point out that, from the definitions of  $\psi_n$  and  $\Psi_n$ , the following is clear, for each  $n \geq 0$ :

a)  $\Psi_n = f$  in the complement of  $\text{supp } R_n \subset \bigcup_{-n}^n f^k(P)$ ;

b)  $\psi_n = f$  in the complement of  $\text{supp } \rho_n \subset [f^n(P) \cup f^{-n}(P)] \setminus \bigcup_{-n+1}^{n-1} f^k(\overline{P})$ ;

c)  $\Psi_n = \begin{cases} \Psi_{n-1} & \text{within } \bigcup_{-n+1}^{n-1} f^k(P) \\ \psi_n & \text{without } \bigcup_{-n+1}^{n-1} f^k(P) \end{cases} ;$

d)  $\Psi_n^{-1} = \begin{cases} \Psi_{n-1}^{-1} & \text{within } \bigcup_{-n+2}^n f^k(P) = \Psi_{n-1}^{-1} \left( \bigcup_{-n+1}^{n-1} f^k(P) \right) \\ \psi_n^{-1} & \text{without } \bigcup_{-n+2}^n f^k(P) = \psi_n^{-1} \left( \bigcup_{-n+1}^{n-1} f^k(P) \right) \end{cases} .$

Having said this, let us go back to the proof of  $\bigcup_0^2 f^k(P) = \bigcup_0^2 P(k)$ . Notice that from c) above we have

$$P(2) = \Psi_1(P(1)) = \begin{cases} \Psi_0(P(1)) & \text{within } P \\ \psi_1(P(1)) & \text{without } P \end{cases}$$

and, since we have seen that  $P(0) = P$  and  $P(1) = f(P)$ ,

$$\begin{aligned} \Psi_1(P(1)) &= \Psi_1(P(1) \cap P(0)) \cup \Psi_1(P(1) \setminus P(0)) \\ &= [\Psi_1(P(1)) \cap \Psi_0(P(0))] \cup [\Psi_1(f(P) \setminus P)] \\ &= [P(2) \cap P(1)] \cup [\psi_1(f(P) \setminus P)] \\ &= [P(2) \cap f(P)] \cup [\psi_1(f(P)) \setminus f(P)] \end{aligned}$$

where the last equality is a consequence of b) above. Thus

$$\begin{aligned}
\bigcup_0^2 P(k) &= \Psi_1(P(1)) \cup \bigcup_0^1 P(k) \\
&= \Psi_1(P(1)) \cup \bigcup_0^1 f^k(P) \\
&= \psi_1(f(P)) \cup \bigcup_0^1 f^k(P) \\
&= \bigcup_0^2 f^k(P)
\end{aligned}$$

where the last equality is a consequence of Corollary 5.10 (i), with  $n = 1$ .

We now show that  $\bigcup_{-1}^1 f^k(P) = \bigcup_{-1}^1 P(k)$ . From d) above we have

$$P(-1) = \Psi_1^{-1}(P(0)) = \begin{cases} \Psi_0^{-1}(P(0)) & \text{within } f(P) = P(1) \\ \psi_1^{-1}(P(0)) & \text{without } f(P) = P(1) \end{cases}$$

so that

$$\begin{aligned}
\Psi_1^{-1}(P(0)) &= \Psi_1^{-1}(P(0) \cap P(1)) \cup \Psi_1^{-1}(P(0) \setminus P(1)) \\
&= [\Psi_1^{-1}(P(0)) \cap \Psi_0^{-1}(P(1))] \cup \Psi_1^{-1}(P \setminus f(P)) \\
&= [P(-1) \cap P(0)] \cup [\psi_1^{-1}(P \setminus f(P))] \\
&= [P(-1) \cap P] \cup [\psi_1^{-1}(P) \setminus P]
\end{aligned}$$

where the last equality is a consequence of b). From this we see that

$$\begin{aligned}
\bigcup_{-1}^1 P(k) &= \bigcup_0^1 P(k) \cup \Psi_1^{-1}(P(0)) \\
&= \bigcup_0^1 f^k(P) \cup \Psi_1^{-1}(P(0)) \\
&= \bigcup_0^1 f^k(P) \cup \psi_1^{-1}(P) \\
&= \bigcup_{-1}^1 f^k(P)
\end{aligned}$$

where the last equality is again a consequence of Corollary 5.10 (ii), with  $n = 1$ . This completes the proof of (i) and (ii) for  $n = 2$ . Suppose we have proven that (i) and (ii) hold for  $2 \leq n \leq N$ . From this assumption the assertions below follow:

$$1) \bigcup_{-n+1}^n f^k(P) = \bigcup_{-n+1}^n P(k), \text{ for } 2 \leq n \leq N, \text{ by just taking the union of (i) and (ii).}$$

$$2) f^n(P) = P(n) \text{ and } f^{-n+1}(P) = P(-n+1) \text{ in the complement of } \bigcup_{-n+2}^{n-1} f^k(P) = \bigcup_{-n+2}^{n-1} P(k),$$

for  $0 \leq n \leq N$ . This can be seen as follows: by (i),  $\bigcup_{-n+2}^n f^k(P) = \bigcup_{-n+2}^n P(k)$  and by 1),

$$\bigcup_{-n+2}^{n-1} f^k(P) = \bigcup_{-n+2}^{n-1} P(k). \text{ Then}$$

$$f^n(P) \cup \bigcup_{-n+2}^{n-1} f^k(P) = P(n) \cup \bigcup_{-n+2}^{n-1} P(k).$$

It then follows that  $f^n(P) = P(n)$  in the complement of  $\bigcup_{-n+2}^{n-1} f^k(P) = \bigcup_{-n+2}^{n-1} P(k)$ . The other part is proven similarly.

3)  $\Psi_n(P(j)) = P(j+1)$  for any  $-n \leq j \leq n$ ,  $0 \leq n \leq N$ . For notice that  $\Psi_n = \Psi_{|j|}$  in  $\bigcup_{-|j|}^{|j|} f^k(P) = \bigcup_{-|j|}^{|j|} P(k) \supset P(j)$ . Thus  $\Psi_n(P(j)) = \Psi_{|j|}(P(j)) = P(j+1)$  from the definition of  $P(j)$ . This reasoning is valid for  $-n \leq j \leq n$ ,  $0 \leq n < N$ . For  $n = N$  what remains to be shown is that  $\Psi_N(P(N)) = P(N+1)$  and  $\Psi_N(P(-N)) = P(N+1)$  or equivalently  $P(-N) = \Psi_N^{-1}(P(-N+1))$ . But these are just the definitions again.

We now proceed to prove (i) and (ii) for  $N+1$ . We start with (ii)  $\bigcup_{-N+1}^{N+1} P(k) = \bigcup_{-N+1}^{N+1} f^k(P)$ .

From c) in the beginning of the proof

$$P(N+1) = \Psi_N(P(N)) = \begin{cases} \Psi_{N-1}(P(N)) & \text{within } \bigcup_{-N+1}^{N-1} f^k(P) \\ = \bigcup_{-N+1}^{N-1} P(k) \\ \psi_N(P(N)) & \text{without } \bigcup_{-N+1}^{N-1} f^k(P) \\ = \bigcup_{-N+1}^{N-1} P(k) \end{cases}$$

Thus,

$$\begin{aligned}
\Psi_N(P(N)) &= \Psi_N \left( P(N) \cap \bigcup_{-N+1}^{N-1} P(k) \right) \cup \Psi_N \left( P(N) \setminus \bigcup_{-N+1}^{N-1} P(k) \right) \\
&= \left[ \Psi_N(P(N)) \cap \Psi_{N-1} \left( \bigcup_{-N+1}^{N-1} P(k) \right) \right] \cup \\
&\quad \Psi_N \left( f^N(P) \setminus \bigcup_{-N+1}^{N-1} f^k(P) \right) \\
&= \left[ P(N+1) \cap \bigcup_{-N+2}^N P(k) \right] \cup \psi_N \left( f^N(P) \setminus \bigcup_{-N+1}^{N-1} f^k(P) \right) \\
&= \left[ P(N+1) \cap \bigcup_{-N+2}^N f^k(P) \right] \cup \left[ \psi_N(f^N(P)) \setminus \bigcup_{-N+2}^N f^k(P) \right]
\end{aligned}$$

where we used 2) in the second equality, 3) in the third and b) from the beginning in the fourth, not to mention the induction hypothesis here and there. From this it follows that

$$\begin{aligned}
\bigcup_{-N+1}^{N+1} P(k) &= \Psi_N(P(N)) \cup \bigcup_{-N+1}^N P(k) \\
&= \Psi_N(P(N)) \cup \bigcup_{-N+1}^N f^k(P) \\
&= \psi_N(f^N(P)) \cup \bigcup_{-N+1}^N f^k(P) \\
&= \bigcup_{-N+1}^{N+1} f^k(P)
\end{aligned}$$

where the last equality comes from Corollary 5.10 (i) with  $n = N$ .

We now prove (i)  $\bigcup_{-N}^N P(k) = \bigcup_{-N}^N f^k(P)$ . From d) we have

$$P(-N) = \Psi_N^{-1}(P(-N+1)) = \begin{cases} \Psi_{N-1}^{-1}(P(-N+1)) \text{ within} \\ \bigcup_{-N+2}^N f^k(P) = \bigcup_{-N+2}^N P(k) \\ \Psi_N^{-1}(P(-N+1)) \text{ without} \\ \bigcup_{-N+2}^N f^k(P) = \bigcup_{-N+2}^N P(k) \end{cases}$$

Thus

$$\begin{aligned}
\Psi_N^{-1}(P(-N+1)) &= \Psi_N^{-1} \left( P(-N+1) \cap \bigcup_{-N+2}^N P(k) \right) \cup \\
&\quad \Psi_N^{-1} \left( P(-N+1) \setminus \bigcup_{-N+2}^N P(k) \right) \\
&= \left[ \Psi_N^{-1}(P(-N+1)) \cap \Psi_{N-1}^{-1} \left( \bigcup_{-N+2}^N P(k) \right) \right] \cup \\
&\quad \Psi_N^{-1} \left( f^{-N+1}(P) \setminus \bigcup_{-N+2}^N f^k(P) \right) \\
&= \left[ P(-N) \cap \bigcup_{-N+1}^{N-1} P(k) \right] \cup \\
&\quad \psi_N^{-1} \left( f^{-N+1}(P) \setminus \bigcup_{-N+2}^N f^k(P) \right) \\
&= \left[ P(-N) \cap \bigcup_{-N+1}^{N-1} f^k(P) \right] \cup \\
&\quad \left[ \psi_N^{-1}(f^{-N+1}(P)) \setminus \bigcup_{-N+1}^{N-1} f^k(P) \right]
\end{aligned}$$

where we have used 2) in the second equality, 3) in the third, b) in the fourth and the induction hypothesis.

Therefore

$$\begin{aligned}
\bigcup_{-N}^N P(k) &= \bigcup_{-N+1}^N P(k) \cup \Psi_N^{-1}(P(-N+1)) \\
&= \bigcup_{-N+1}^N f^k(P) \cup \Psi_N^{-1}(P(-N+1)) \\
&= \bigcup_{-N+1}^N f^k(P) \cup \psi_N^{-1}(P(-N+1)) \\
&= \bigcup_{-N}^N f^k(P)
\end{aligned}$$

where the last equality comes from Corollary 5.10 (ii) with  $n = N$ . This completes the proof.  $\square$

**Corollary 5.13** For  $n \geq 1$

$$(i) \quad \bigcup_{n+1}^n f^k(P) = \bigcup_{-n+1}^n P(k);$$

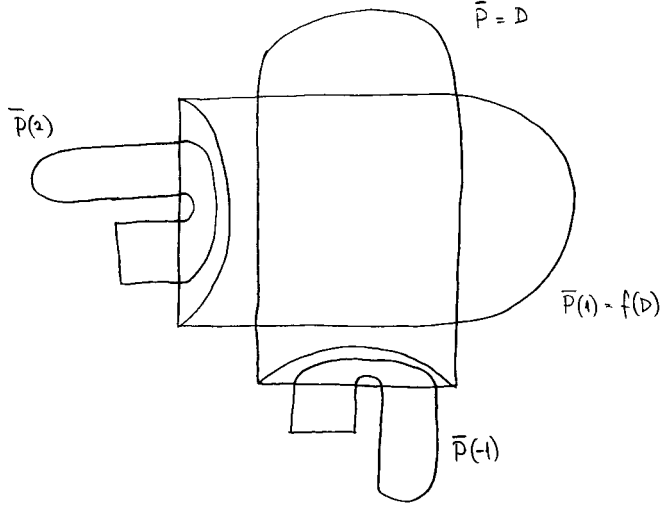

Figure 19:  $\bar{P}(k), k = -1, 0, 1, 2$ , for a pruning collection containing only one  $(c, e)$ -disk  $D$ .

(ii)  $f^n(P) = P(n)$  and  $f^{-n+1}(P) = P(-n+1)$  in the complement of

$$\bigcup_{-n+2}^{n-1} f^k(P) = \bigcup_{-n+2}^{n-1} P(k).$$

PROOF: The proof is the same as that given for 1) and 2) in the proof of Proposition 5.12.  $\square$

**Corollary 5.14** *If  $\Psi$  is as we defined above,  $P(k) = \Psi(P(k-1))$  for every  $k \in \mathbb{Z}$ , that is  $\{P(k); k \in \mathbb{Z}\}$  is an orbit under  $\Psi$ .*

PROOF: Just notice that  $\Psi = \Psi_n$  in  $\bigcup_{-n}^n f^k(P)$  and argue like in the proof of 3) in Proposition 5.12.  $\square$

We are now going to define new closed disks  $A_i, i \in \underline{L}$  whose union is still the closed pruning front  $\bar{P}$ . We will see that the cross-cut  $\alpha_i(0) \subset D_i$  is also a cross-cut in  $A_i$  and divides it into two disks  $A_i^c$  and  $A_i^e$  (see figure 20.) These will have some disjoint/nested properties we will make precise later and will be useful in the proof of the theorem.

**Definition 5.15** *Let  $A_L = A_L(0) = D_L$  and, for  $1 \leq i \leq L$ , set  $A_i = A_i(0) = \zeta_{L,0}^{-1} \circ \dots \circ \zeta_{i+1,0}^{-1}(D_i)$ . Then define inductively for  $n \geq 1$ ,  $A_i(n) = \Psi(A_i(n-1))$  and  $A_i(-n) = \Psi^{-1}(A_i(-n+1))$ .*

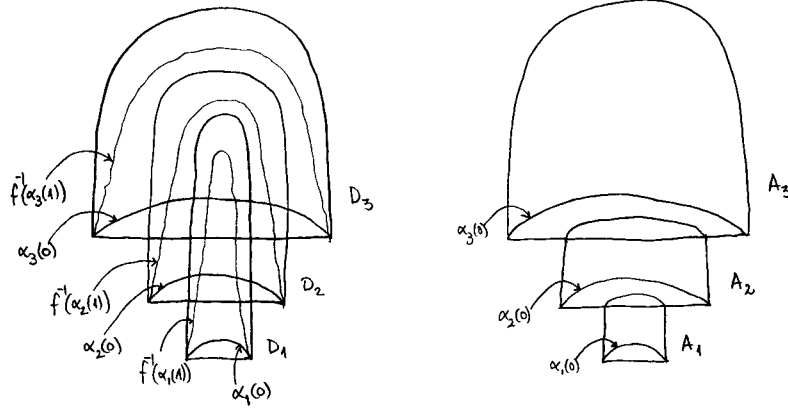

Figure 20: The  $D_i$ 's and the  $A_i$ 's

**Proposition 5.16** For  $l \in \underline{L}$ ,  $\bigcup_{i=l}^L A_i = \bigcup_{i=l}^L D_i$ . In particular  $\bigcup_{i=1}^L A_i = \overline{P}$ .

PROOF: By definition  $A_L = D_L$ . Assume we have shown that  $\bigcup_{i=l+1}^L A_i = \bigcup_{i=l+1}^L D_i$ . Then

$$\begin{aligned}
 \bigcup_{i=l}^L A_i &= \bigcup_{i=l+1}^L A_i \cup A_l \\
 &= \bigcup_{i=l+1}^L D_i \cup \zeta_{L,0}^{-1} \circ \dots \circ \zeta_{l+1,0}^{-1}(D_l) \\
 &= \bigcup_{i=l}^L D_i
 \end{aligned}$$

where the last equality holds because  $\text{supp } \zeta_{L,0}^{-1} \circ \dots \circ \zeta_{l+1,0}^{-1} \subset \bigcup_{i=l+1}^L D_i$ .  $\square$

**Corollary 5.17** For every  $n \in \mathbb{Z}$ ,  $\overline{P}(n) = \bigcup_{i=1}^L A_i(n)$ .  $\square$

**Proposition 5.18** For  $n \geq 1$  and  $i \in \underline{L}$ ,

(i)  $\zeta_n \left( \bigcup_{j \leq i} f^n(D_j) \right) = \bigcup_{j \leq i} f^n(D_j);$

$$(ii) \quad \zeta_{-n} \left( \bigcup_{j \geq i} f^{-n}(D_j) \right) = \bigcup_{j \geq i} f^{-n}(D_j).$$

PROOF: If  $k > i \geq j$  then  $D_k \not\subset D_j$  and we have seen that for  $n \geq 1$ ,  $I^c(\gamma_k(n))$  is either contained in  $f^n(I_j)$  or it is disjoint from  $f^n(D_j)$ . If  $I^c(\gamma_k(n))$  is contained in  $f^n(I_j)$  it is because  $f^n(D_k)$ ,  $f^n(D_j)|_{f^n(C_k)}$  and therefore  $f(D_k)$ ,  $f(D_j)|_{f(C_k)}$ . By Proposition 5.3,  $N(i) = 1$  and it follows that  $k_{i,n} \equiv \text{identity}$ . If  $I^c(\gamma_k(n))$  is disjoint from  $f^n(D_j)$  so is  $\mathcal{V}_k(n)$ , since  $\mathcal{V}_k(n) \subset I^c(\gamma_k(n))$ . Either way we see that  $(\text{supp } \zeta_{k,n}) \cap f^n(D_j) = \emptyset$ . Thus

$$\begin{aligned} \zeta_n \left( \bigcup_{j \leq i} f^n(D_j) \right) &= \zeta_{1,n} \circ \dots \circ \zeta_{L,n} \left( \bigcup_{j \leq i} f^n(D_j) \right) \\ &= \zeta_{1,n} \circ \dots \circ \zeta_{i,n} \left( \bigcup_{j \leq i} f^n(D_j) \right) \\ &= \bigcup_{j \leq i} f^n(D_j) \end{aligned}$$

where the last equality holds because  $\text{supp } \zeta_{1,n} \circ \dots \circ \zeta_{i,n} \subset \bigcup_{j \leq i} f^n(D_j)$ . This proves (i). (ii) is proven analogously.  $\square$

The next proposition and corollary are analogous to Proposition 5.9 and Corollary 5.10. The proofs use Proposition 5.18 but are otherwise completely similar. We omit them.

**Proposition 5.19** For  $n \geq 1$  and  $i \in \underline{L}$ ,

$$(i) \quad \rho_n \left( \bigcup_{j \leq i} f^n(D_j) \right) \cup f^{-n}(P) = \bigcup_{j \leq i} f^n(D_j) \cup f^{-n}(P);$$

$$(ii) \quad f^n(P) \cup \rho_n^{-1} \left( \bigcup_{j \geq i} f^{-n}(D_j) \right) = f^n(P) \cup \bigcup_{j \geq i} f^{-n}(D_j). \quad \square$$

**Corollary 5.20** For  $n \geq 1$  and  $i \in \underline{L}$ ,

$$(i) \quad \psi_n \left( \bigcup_{j \leq i} f^n(D_j) \right) \cup f^{-n+1}(P) = \bigcup_{j \leq i} f^{n+1}(D_j) \cup f^{-n+1}(P);$$

$$(ii) \quad f^n(P) \cup \psi_n^{-1} \left( \bigcup_{j \geq i} f^{-n+1}(D_j) \right) = f^n(P) \cup \bigcup_{j \geq i} f^{-n}(D_j). \quad \square$$



We can now state and prove a proposition which sharpens Proposition 5.12 somewhat. Although the proof goes along the same lines as that of Proposition 5.12 we present it for completeness.

**Proposition 5.21** *For  $n \geq 1$  and  $i \in \underline{L}$  we have*

$$(i) \bigcup_{j \leq i} f^n(D_j) \cup \bigcup_{-n+2}^{n-1} f^k(P) = \bigcup_{j \leq i} A_j(n) \cup \bigcup_{-n+2}^{n-1} P(k);$$

$$(ii) \bigcup_{j \geq i} f^{-n+1}(D_j) \cup \bigcup_{-n+2}^{n-1} f^k(P) = \bigcup_{j \geq i} A_j(-n+1) \cup \bigcup_{-n+2}^{n-1} P(k).$$

PROOF: The proof is by induction on  $n$ . Notice that for  $n = 1$ , (ii) above is just Corollary 5.17. In order to prove (i) with  $n = 1$ , observe that, since  $A_i = A_i(0) \subset \overline{P}$ ,  $A_i(1) = \Psi(A_i(0)) = \psi_0(A_i(0)) = f \circ \rho_0(A_i(0))$ . Thus

$$\begin{aligned} A_i(1) &= f \circ \rho_0(\zeta_{L,0}^{-1} \circ \dots \circ \zeta_{i+1,0}^{-1}(D_i)) \\ &= f \circ (\zeta_{1,0} \circ \dots \circ \zeta_{L,0}) \circ (\zeta_{L,0}^{-1} \circ \dots \circ \zeta_{i+1,0}^{-1}(D_i)) \\ &= f \circ (\zeta_{1,0} \circ \dots \circ \zeta_{i,0})(D_i) \end{aligned}$$

Reasoning as in the proof of Corollary 5.17, it is easy to prove that  $\bigcup_{j \leq i} A_j(1) = \bigcup_{j \leq i} f(D_j)$  which is (i) for  $n = 1$ .

Assume we have shown that

$$\bigcup_{j \leq i} A_j(n) \cup \bigcup_{-n+2}^{n-1} P(k) = \bigcup_{j \leq i} f^n(D_j) \cup \bigcup_{-n+2}^{n-1} f^k(P).$$

Then, since we know that  $\bigcup_{-n+1}^{n-1} P(k) = \bigcup_{-n+1}^{n-1} f^k(P)$  and  $\bigcup_{-n+1}^n P(k) = \bigcup_{-n+1}^n f^k(P)$  by Proposition 5.12, just like in the proof of that proposition we can see that

$$\bigcup_{j \leq i} A_j(n) \setminus \bigcup_{-n+1}^{n-1} P(k) = \bigcup_{j \leq i} f^n(D_j) \setminus \bigcup_{-n+1}^{n-1} f^k(P).$$

Using all this information we have

$$\begin{aligned}
\bigcup_{j \leq i} A_j(n+1) \cup \bigcup_{-n+1}^n P(k) &= \left[ \bigcup_{j \leq i} A_j(n+1) \setminus \bigcup_{-n+2}^n P(k) \right] \cup \bigcup_{-n+1}^n P(k) \\
&= \left[ \Psi \left( \bigcup_{j \leq i} A_j(n) \setminus \bigcup_{-n+1}^{n-1} P(k) \right) \right] \cup \bigcup_{-n+1}^n P(k) \\
&= \left[ \Psi \left( \bigcup_{j \leq i} f^n(D_j) \setminus \bigcup_{-n+1}^{n-1} f^k(P) \right) \right] \cup \bigcup_{-n+1}^n f^k(P) \\
&= \left[ \psi_n \left( \bigcup_{j \leq i} f^n(D_j) \setminus \bigcup_{-n+1}^{n-1} f^k(P) \right) \right] \cup \bigcup_{-n+1}^n f^k(P) \\
&= \left[ \psi_n \left( \bigcup_{j \leq i} f^n(D_j) \right) \setminus \bigcup_{-n+2}^n f^k(P) \right] \cup \bigcup_{-n+1}^n f^k(P) \\
&= \psi_n \left( \bigcup_{j \leq i} f^n(D_j) \right) \cup \bigcup_{-n+1}^n f^k(P) \\
&= \bigcup_{j \leq i} f^{n+1}(D_j) \cup \bigcup_{-n+1}^n f^k(P)
\end{aligned}$$

where the last equality holds by Corollary 5.20, (i). Statement (ii) is proven analogously and we leave it to the interested reader.  $\square$

**Corollary 5.22** For  $n \geq 1$  and  $i \in \underline{L}$  we have:

(i)  $A_i(n) = f^n(D_i)$  in the complement of

$$\bigcup_{j < i} f^n(D_j) \cup \bigcup_{-n+2}^{n-1} f^k(P) = \bigcup_{j < i} A_j(n) \cup \bigcup_{-n+2}^{n-1} P(k);$$

(ii)  $A_i(-n+1) = f^{-n+1}(D_i)$  in the complement of

$$\bigcup_{j > i} f^{-n+1}(D_j) \cup \bigcup_{-n+2}^{n-1} f^k(P) = \bigcup_{j > i} A_j(-n+1) \cup \bigcup_{-n+2}^{n-1} P(k). \quad \square$$

**Proposition 5.23** For each  $i \in \underline{L}$ ,  $\alpha_i(0)$  is a cross-cut in  $A_i$  and divides  $A_i$  into two closed disks  $A_i^c$  and  $A_i^e$  bounded by  $\rho_0^{-1}(C_i) \cup \alpha_i(0)$  and  $\alpha_i(0) \cup E_i$ , respectively.

PROOF: In the proof of Proposition 5.4 (iii), we have shown that for each  $i \in \underline{L}$ ,  $\rho_0(\alpha_i(0)) = \zeta_0(\alpha_i(0)) = \zeta_{1,0} \circ \dots \circ \zeta_{i,0}(\alpha_i(0))$ . Thus we see that

$$\begin{aligned} \alpha_i(0) &= \rho_0^{-1}(\zeta_{1,0} \circ \dots \circ \zeta_{i,0}(\alpha_i(0))) \\ &= \zeta_{L,0}^{-1} \circ \dots \circ \zeta_{1,0}^{-1} \circ \zeta_{1,0} \circ \dots \circ \zeta_{i,0}(\alpha_i(0)) \\ &= \zeta_{L,0}^{-1} \circ \dots \circ \zeta_{i+1}^{-1}(\alpha_i(0)) \end{aligned}$$

so that  $\alpha_i(0)$  is left fixed by  $\zeta_{L,0}^{-1} \circ \dots \circ \zeta_{i+1,0}^{-1}$ . Since  $\alpha_i(0)$  is a cross-cut in  $D_i$  and  $A_i = \zeta_{L,0}^{-1} \circ \dots \circ \zeta_{i+1,0}^{-1}(D_i)$ ,  $\alpha_i(0)$  is also a cross-cut in  $A_i$ .

We now show that  $A_i$  is bounded by  $\rho_0^{-1}(C_i) \cup E_i$  which will complete the proof of the proposition. Notice that if  $j \leq i$ ,  $C_i \cap I_j = \emptyset$  so that  $\rho_0^{-1}(C_i) = \zeta_{L,0}^{-1} \circ \dots \circ \zeta_{i+1,0}^{-1}(C_i)$ . On the other hand, for  $j \geq i$ ,  $I_j \cap E_i = \emptyset$  so that  $\zeta_{L,0}^{-1} \circ \dots \circ \zeta_{i+1,0}^{-1}(E_i) = E_i$ . This shows that  $\zeta_{L,0}^{-1} \circ \dots \circ \zeta_{i+1,0}^{-1}(C_i \cup E_i) = \rho_0^{-1}(C_i) \cup E_i$ , as we wanted.  $\square$

**Proposition 5.24** *For each  $i \in \underline{L}$ , (i) and (ii) hold:*

(i) *for  $n \geq 1$ ,  $A_i(n)$  is bounded by the Jordan curve*

$$f^n(C_i) \cup \Psi^n(E_i);$$

(ii) *for  $m \leq 0$ ,  $A_i(m)$  is bounded by the Jordan curve*

$$\Psi^m(\rho_0^{-1}(C_i)) \cup f^m(E_i) = \Psi^{m-1}(f(C_i)) \cup f^m(E_i).$$

PROOF: In the proof of Proposition 5.23 we saw that  $A_i(0)$  is bounded by  $\rho_0^{-1}(C_i) \cup E_i = \psi_0^{-1}(f(C_i)) \cup E_i = \Psi^{-1}(f(C_i)) \cup E_i$ . Therefore  $A_i(1) = \Psi(A_i(0))$  is bounded by  $\Psi(\Psi^{-1}(f(C_i)) \cup E_i) = f(C_i) \cup \Psi(E_i)$ , which proves (i) and (ii) for  $n = 1$  and  $m = 0$  respectively. The general result is now proved by induction using Corollary 3.27 to guarantee that  $\Psi^n(f(C_i)) = f^{n+1}(C_i)$  for  $n \geq 0$  and that  $\Psi^m(E_i) = f^m(E_i)$  for  $m \leq 0$ .  $\square$

**Definition 5.25** *Let  $A_i^c(0) = A_i^c$  and  $A_i^e(0) = A_i^e$  as in Proposition 5.23 and define inductively for  $n \geq 1$ ,  $A_i^{c(e)}(n) = \Psi(A_i^{c(e)}(n-1))$  and  $A_i^{c(e)}(-n) = \Psi^{-1}(A_i^{c(e)}(-n+1))$  (see figure 21.)*

**Proposition 5.26** *With the notation just introduced we have:*

(i)  $A_i^c(n) = D^c(\alpha_i(n))$  for  $1 \leq n \leq N(i)$ ;

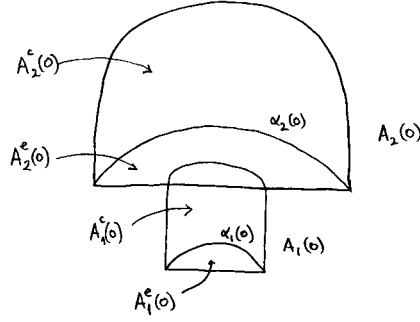

Figure 21:  $A_i^c(0)$  and  $A_i^e(0)$  for  $i = 1, 2$ .

(ii)  $A_i^e(m) = D^e(\alpha_i(m))$  for  $M(i) \leq m \leq 0$ .

PROOF: That  $A_i^e = D^e(\alpha_i(0))$  is a direct consequence of Proposition 5.23, since  $A_i^e$  is bounded by  $\alpha_i(0) \cup E_i$  which is the same curve that bounds  $D^e(\alpha_i(0))$ . On the other hand,  $A_i^c(0)$  is bounded by  $\rho_0^{-1}(C_i) \cup \alpha_i(0)$  and it follows that  $A_i^c(1) = \Psi(A_i^c(0))$  is bounded by

$$\Psi(\rho_0^{-1}(C_i) \cup \alpha_i(0)) = \psi_0(\rho_0^{-1}(C_i) \cup \alpha_i(0)) = f(C_i) \cup \alpha_i(1).$$

This shows that  $A_i^c(1) = D^c(\alpha_i(1))$ .

Assume we have shown that  $A_i^c(n) = D^c(\alpha_i(n))$  for  $n < N(i)$ . Then, using Proposition 5.6 (i), we see that

$$\begin{aligned} A_i^c(n+1) &= \Psi(A_i^c(n)) \\ &= f\rho(D^c(\alpha_i(n))) \\ &= f(D^c(f^{-1}(\alpha_i(n+1)))) \\ &= D^c(\alpha_i(n+1)) \end{aligned}$$

This proves (i). (ii) is proven similarly.  $\square$

Let  $n(i), N(i), m(i)$  and  $M(i)$  be as we defined them in the beginning of this section. By Proposition 5.2 if  $n(i), m(i)$  are finite then  $n(i) = 2N(i) - \delta, m(i) = 2M(i) - \delta'$ , where  $\delta, \delta' = 0$  or 1. Moreover,

$$f^{N(i)}(D_i), f^{-N(i)+\delta+1}(D_j)|_{f^{N(i)}(C_i)}$$

and

$$f^{M(i)}(D_i), f^{-M(i)+\delta'}(D_l)|_{f^{M(i)}(E_i)}$$

for some  $j, l \in \underline{L}$ . Recall also that if  $D_1, D_2|_L$  and  $D_1 \setminus L \subset I_2$  we write  $D_1 \subset D_2|_L$ . We can now state

**Proposition 5.27** *With the above notation for each  $i \in \underline{L}$ , (i) and (ii) hold:*

(i) *If  $n(i) < \infty$  and  $j \in \underline{L}$  is largest such that*

$$f^{N(i)}(D_i), f^{-N(i)+\delta+1}(D_j)|_{f^{N(i)}(C_i)}$$

*then*

$$A_i^c(N(i)) \subset A_j(-N(i) + \delta + 1)|_{f^{N(i)}(C_i)};$$

(ii) *if  $m(i) > -\infty$  and  $j \in \underline{L}$  is smallest such that*

$$f^{M(i)}(D_i), f^{-M(i)+\delta'}(D_j)|_{f^{M(i)}(E_i)}$$

*then*

$$A_i^c(M(i)) \subset A_j(-M(i) + \delta')|_{f^{M(i)}(E_i)}.$$

PROOF: By Proposition 5.26 we know that  $A_i^c(N(i)) = D^c(\alpha_i(N(i)))$ . We have to show that  $f^{N(i)}(C_i) \subset \partial A_j(-N(i) + \delta + 1)$  and that

$$\begin{aligned} A_i^c(N(i)) \setminus f^{N(i)}(C_i) &= D^c(\alpha_i(N(i))) \setminus f^{N(i)}(C_i) \\ &= I^c(\alpha_i(N(i))) \cup \alpha_i(N(i)) \\ &\subset I(A_j(-N(i) + \delta + 1)) \end{aligned}$$

where the last set is the interior of  $A_j(-N(i) + \delta + 1)$  and the second equality is just the definition and only the last inclusion needs proof (see figure 22.)

Let us first show that

$$f^{N(i)}(C_i) \subset \partial A_j(-N(i) + \delta + 1).$$

By assumption

$$f^{N(i)}(D_i), f^{-N(i)+\delta+1}(D_j)|_{f^{N(i)}(C_i)}$$

which implies that

$$f^{N(i)}(C_i) \subset f^{-N(i)+\delta+1}(C_j).$$

If  $n(i) = 1$ , then  $N(i) = 1$  and  $\delta = 1$ , so that by Proposition 5.24 and the above we have  $f(C_i) \subset f(C_j) \subset \partial A_j(1)$ . If  $n(i) > 1$ , applying  $f^{N(i)-\delta-1}$  to the inclusion  $f^{N(i)}(C_i) \subset f^{-N(i)+\delta+1}(C_j)$  we

get  $f^{n(i)-1}(C_i) \subset C_j$ . From Corollary 3.27 we know that  $f^n(C_i) \cap \text{supp } R = \emptyset$  for  $n \geq 1$ . In particular,  $f^{n(i)-1}(C_i) \cap \text{supp } \rho_0 = \emptyset$ , and it follows that  $f^{n(i)-1}(C_i) \subset \rho_0^{-1}(C_j) \subset \partial A_j(0)$ , this last inclusion coming from Proposition 5.24. Also, if  $k < n(i)$  then  $\Psi^{-k}(f^{n(i)}(C_i)) = f^{-k}(f^{n(i)}(C_i)) = f^{n(i)-k}(C_i)$ , so that

$$\begin{aligned} \Psi^{-N(i)+\delta+1}(f^{n(i)-1}(C_i)) &= f^{N(i)}(C_i) \\ &\subset \Psi^{-N(i)+\delta+1}(\rho_0^{-1}(C_i)) \\ &\subset \partial A_j(-N(i) + \delta + 1) \end{aligned}$$

as we wanted.

In order to see that  $I^c(\alpha_i(N(i))) \cup \alpha_i(N(i)) \subset I(A_j(-N(i) + \delta + 1))$  first notice that, since  $\{\alpha_l(N(i))\}_{l=1}^L$  is a  $(\varepsilon_{N(i)}, c)$ -collection compatible with

$$\{(f^k(D_j), \alpha_j(k)); j \in \underline{L}, -N(i) + 1 \leq k \leq N(i) - 1\}$$

and that

$$f^{N(i)}(D_i), f^{-N(i)+\delta+1}(D_j)|_{f^{N(i)}(C_i)}$$

then

$$I^c(\alpha_i(N(i))) \cup \alpha_i(N(i)) \subset f^{-N(i)+\delta+1}(I_j).$$

We will now show that

$$[I^c(\alpha_i(N(i))) \cup \alpha_i(N(i))] \cap \left[ \bigcup_{l>j} f^{-N(i)+\delta+1}(D_l) \cup \bigcup_{-N(i)+\delta+2}^{N(i)-\delta-1} f^k(\bar{P}) \right] = \emptyset.$$

This is so because by assumption  $f^{N(i)}(D_i), f^{-N(i)+\delta+1}(D_l) \not\ll_{f^{N(i)}(C_i)}$  for  $l > j$  and from Proposition 5.2 (ii),  $f^{N(i)}(D_i), f^k(D_j) \not\ll_{f^{N(i)}(C_i)}$  for any  $j \in \underline{L}$  and  $-N(i) + \delta + 2 \leq k \leq N(i) - 1$ . This together with the aforementioned compatibility of  $\{\alpha_i(N(i))\}_{l=1}^L$  are exactly what we need in order to verify the equation above. By Corollary 5.22 (ii),

$$A_j(-N(i) + \delta + 1) = f^{-N(i)+\delta+1}(D_j)$$

in the complement of

$$\bigcup_{l>j} f^{-N(i)+\delta+1}(D_l) \cup \bigcup_{-N(i)+\delta+2}^{N(i)-\delta-1} f^k(P)$$

which shows that

$$I^c(\alpha_i(N(i))) \cup \alpha_i(N(i)) \subset A_j(-N(i) + \delta + 1).$$

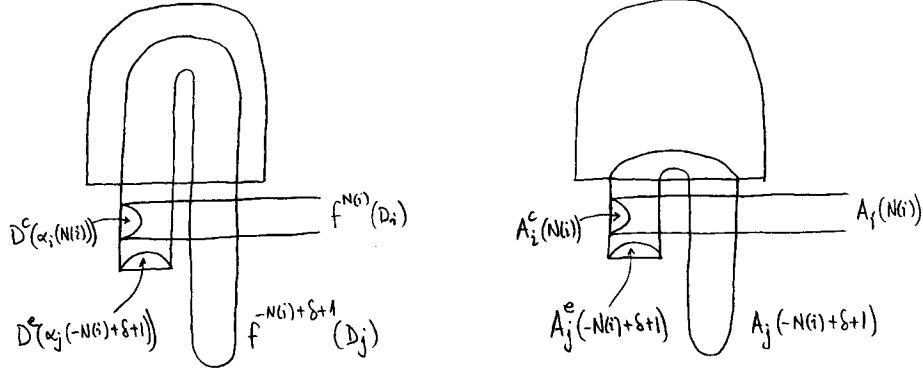

Figure 22: A possible configuration for  $f^{N(i)}(D_i)$ ,  $f^{-N(i)+\delta+1}(D_j)$  and  $A_i(N(i))$ ,  $A_j(-N(i)+\delta+1)$  and  $A_i^c(N(i))$ .

We leave it for the reader to show that it is possible to put  $I(A_j(-N(i)+\delta+1))$  in place of  $A_j(-N(i)+\delta+1)$  in the inclusion above.  $\square$

**Proposition 5.28** *Under the hypotheses of Proposition 5.27 (i) and (ii) respectively, (i') and (ii') below hold:*

$$(i') \quad A_i^c(N(i)) \subset A_j^c(-N(i)+\delta+1)|_{f^{N(i)}(C_i)};$$

$$(ii') \quad A_i^e(M(i)) \subset A_j^e(-M(i)+\delta')|_{f^{M(i)}(E_i)}.$$

PROOF: By Proposition 5.27,  $A_i^c(N(i)) \subset A_j^c(-N(i)+\delta+1)|_{f^{N(i)}(C_i)}$ . Therefore all we need to prove is that

$$[I^c(\alpha_i(N(i))) \cup \alpha_i(N(i))] \cap A_j^e(-N(i)+\delta+1) = \emptyset.$$

There are two cases to be considered:  $M(j) \leq -N(i)+\delta+1$  and  $M(j) > -N(i)+\delta+1$ . If  $M(j) \leq -N(i)+\delta+1$ , by Proposition 5.26,

$$A_j^e(-N(i)+\delta+1) = D^e(\alpha_j(-N(i)+\delta+1))$$

and, since  $\{\alpha_l(N(i))\}_{l=1}^L$  is a  $(\varepsilon_{N(i)}, c)$ -collection compatible with

$$\{(f^k(D_j), \alpha_j(k)); j \in \underline{L}, -N(i)+1 \leq k \leq N(i)-1\},$$

then

$$[I^c(\alpha_i(N(i))) \cup \alpha_i(N(i))] \subset I^c(\alpha_j(-N(i)+\delta+1))$$

so that

$$[I^c(\alpha_i(N(i))) \cup \alpha_i(N(i))] \cap D^e(-N(i) + \delta + 1) = \emptyset,$$

as we wanted.

If  $M_j > -N(i) + \delta + 1$ , there exists  $l \in \underline{L}$  such that

$$f^{M(j)}(D_j), f^{-M(j)+\delta'}(D_l)|_{f^{M(j)}(E_j)}$$

where  $m(j) = 2M(j) + \delta'$ , and, assuming  $l$  is the smallest such, by Proposition 5.28 (ii), we can conclude that  $A_j^e(M(j)) \subset A_l(-M(j) + \delta')$ . Therefore

$$\begin{aligned} A_j^e(-N(i) + \delta + 1) &= \Psi^{-M(j)-N(i)+\delta+1}(A_j^e(M(j))) \\ &\subset \Psi^{-M(j)-N(i)+\delta+1}(A_l(-M(j) + \delta')) \\ &= A_l(-m(j) - N(i) + \delta + 1). \end{aligned}$$

From  $M(j) \geq -N(i) + \delta + 2$  we have

$$\begin{aligned} -m(j) - N(i) + \delta + 1 &= -2M(j) + 2\delta' - N(i) + \delta + 1 \\ &\leq 2N(i) - 2\delta - 4 + 2\delta' - N(i) + \delta + 1 \\ &= N(i) - \delta - 3 - 2\delta' \\ &\leq N(i) - \delta - 1 \end{aligned}$$

If  $m(j) > 0$ , then  $-m(j) - N(i) + \delta + 1 \geq -N(i) + \delta + 2$ , so that

$$A_l(-m(j) - N(i) + \delta + 1) \subset \bigcup_{-N(i)+\delta+2}^{N(i)-\delta-1} \overline{P}(k).$$

If  $m(j) = 0$ , then  $D_j, D_l|_{E_j}$ , which implies that  $D_l \succ D_j$  and therefore that  $l > j$ . With this we have shown that

$$\begin{aligned} A_l(-m(j) - N(i) + \delta + 1) &\subset \bigcup_{l>j} A_l(-N(i) + \delta + 1) \cup \bigcup_{-N(i)+\delta+2}^{N(i)-\delta-1} \overline{P}(k) \\ &= \bigcup_{l>j} f^{-N(i)+\delta+1}(D_l) \cup \bigcup_{-N(i)+\delta+2}^{N(i)-\delta-1} f^k(\overline{P}) \end{aligned}$$

where this last equality is a consequence of Proposition 5.21 (ii). But, from the proof of Proposition 5.27, we have seen that  $I^c(\alpha_i(N(i))) \cup \alpha_i(N(i))$  does not intersect the set after the equal sign just above. This finishes the proof.  $\square$



**Corollary 5.29** *With the same notation as above, for every  $i \in \underline{L}$  the following holds:*

(i) *if  $n(i) < \infty$ , then for every  $j \in \underline{L}$  such that*

$$f^{N(i)}(D_i), f^{-N(i)+\delta+1}(D_j)|_{f^{N(i)}(C_i)}$$

*we have*

$$A_i^c(N(i)) \subset A_j^c(-N(i) + \delta + 1)|_{f^{N(i)}(C_i)};$$

(ii) *if  $m(i) > -\infty$ , then for every  $j \in \underline{L}$  such that*

$$f^{M(i)}(D_i) f^{-M(i)+\delta'}(D_j)|_{f^{M(i)}(E_i)}$$

*we have*

$$A_i^e(M(i)) \subset A_j^e(-M(i) + \delta')|_{f^{M(i)}(E_i)}.$$

PROOF: We have shown that if  $j \in \underline{L}$  is largest such that

$$f^{n(i)}(D_i), f(D_j)|_{f^{n(i)}(C_i)}$$

(which is equivalent to the condition in (i) above) then the desired inclusion holds. Let  $l \in \underline{L}$  be such that  $f^{n(i)}(D_i), f(D_l)|_{f^{n(i)}(C_i)}$ ,  $l \neq j$  (and thus  $l < j$ .) By Proposition 2.9,  $f(D_j), f(D_l)|_{f^{n(i)}(C_i)}$  and since  $l < j$ , we must have  $f(D_l) \prec f(D_j)$ . Since  $\{\alpha_i(1)\}_{i=1}^L$  is a  $(\varepsilon, c)$ -collection, it follows that  $[I^c(\alpha_j(1)) \cup \alpha_j(1)] \subset I^c(\alpha_l(1))$  and by Proposition 5.26 this is equivalent to  $A_j^c(1) \subset A_l^c(1)|_{f(C_j)}$  (see figure 23.) Taking the  $\Psi^{-N(i)+\delta}$ -image of this latter inclusion, we get

$$A_j^c(-N(i) + \delta + 1) \subset A_l^c(-N(i) + \delta + 1)|_{\Psi^{-N(i)+\delta}(f(C_j))}.$$

Notice that  $\Psi^{-N(i)+\delta}(f(C_j)) = \Psi^{-N(i)+\delta+1}(\rho_0^{-1}(C_j))$  and that in the proof of Proposition 5.28 we showed that  $f^{N(i)}(C_i) \subset \Psi^{-N(i)+\delta+1}(\rho_0^{-1}(C_j))$ . Therefore

$$A_i^c(N(i)) \subset A_j^c(-N(i) + \delta + 1)|_{f^{N(i)}(C_i)}$$

and

$$A_j^c(-N(i) + \delta + 1) \subset A_l^c(-N(i) + \delta + 1)|_{\Psi^{-N(i)+\delta+1}(\rho_0^{-1}(C_i))}$$

imply that

$$A_i^c(N(i)) \subset A_l^c(-N(i) + \delta + 1)|_{f^{N(i)}(C_i)}$$

as we wanted.  $\square$

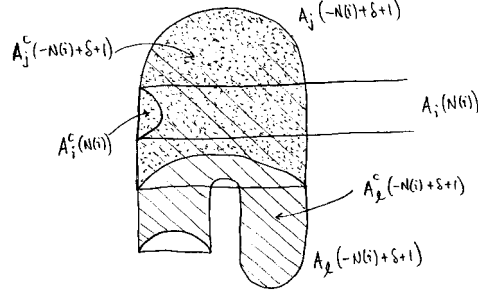

Figure 23: An example of  $A_i(N(i))$ ,  $A_j(-N(i) + \delta + 1)$  and  $A_l(-N(i) + \delta + 1)$ .

**Proposition 5.30**  $\Psi$  has the following properties:

- (i) if  $n(i) = \infty$ , then  $\Psi^n(A_i^c)$  has interior disjoint from  $\overline{P}$  for every  $n > 0$ ;
- (ii) if  $n(i) < \infty$ , then for every  $j \in \underline{L}$  such that  $f^{n(i)}(D_i), f(D_j)|_{f^{n(i)}(C_i)} \Psi^{n(i)}(A_i^c) \subset A_j^c(1)|_{f^{n(i)}(C_i)}$  and  $f^{n(i)}(C_i) \subset f(C_j)$
- (iii) if  $m(i) = -\infty$ , then  $\Psi^m(A_i^e)$  has interior disjoint from  $\overline{P}$  for every  $m < 0$ ;
- (iv) if  $m(i) > -\infty$ , then for every  $j \in \underline{L}$  such that  $f^{m(i)}(D_i), D_j|_{f^{m(i)}(E_i)} \Psi^{m(i)}(A_i^e) \subset A_j^e|_{f^{m(i)}(E_i)}$  and  $f^{m(i)}(E_i) \subset E_j$ .

PROOF: If  $n(i) = \infty$ , then  $N(i) = \infty$  and by Proposition 5.26 we see that  $\Psi^n(A_i^c) = A_i^c(n) = D^c(\alpha_i(n))$  for every  $n \geq 1$ . Since  $f^n(D_i), f^k(D_j) \not\subset_{f^n(C_i)}$  for  $-n + 1 \leq k \leq n - 1$ ,

$$[I^c(\alpha_i(n)) \cup \alpha_i(n)] \cap \bigcup_{-n+1}^{n-1} f^k(\overline{P}) = \emptyset.$$

This being true for every  $n \geq 1$ , we see that  $[I^c(\alpha_i(n)) \cup \alpha_i(n)] \cap \overline{P} = \emptyset$  for every  $n \geq 1$ , which proves

(i). (ii) is immediate from Corollary 5.29. (iii) and (iv) are analogous and we omit the proofs.  $\square$

We can now state and prove the main theorem.

**Theorem 5.31 (Main Theorem)** Let  $f : \pi \rightarrow \pi$  be a homeomorphism of the plane,  $\{D_i\}_{i=1}^L$  a pruning collection and  $P = \bigcup_{i=1}^L I_i$ , where  $I_i$  is the interior of the disk  $D_i$ . Then there exists an isotopy  $H : \pi \times [0, 1] \rightarrow \pi$  of the identity such that  $\text{supp } H \subset \bigcup_{k \in \mathbb{Z}} f^k(P)$ , and if we set  $f_P(\cdot) = f \circ H(\cdot, 1)$ , every point of  $P$  is wandering under  $f_P$ .

PROOF: Construct a directed graph  $G_c$  as follows: its vertices are the integers  $\{i \in \underline{L}; n(i) > 1\}$  and there is a directed vertex from  $i$  to  $j$  if  $n(i) < \infty$  and  $f^{n(i)}(D_i), f(D_j)|_{f^{n(i)}(C_i)}$ . Since we have taken only  $i \in \underline{L}$  for which  $n(i) > 1$ , it is easy to see that from each vertex there is at most one outgoing edge (or none, if  $n(i) = \infty$ ). A *loop* in the directed graph consists of an ordered set of distinct vertices  $\{i_1 < i_2 < \dots < i_l\}$  such that there is a directed edge from  $i_r$  to  $i_{r+1}$ , for  $1 \leq r \leq l$  where we let the indices “wrap around”, i.e.,  $l+1$  “=” 1. Since there is at most one edge emanating from each vertex, and the vertices in a loop are ordered and distinct, it follows that two loops are either equal or disjoint. Let  $\mathcal{L} = \{i_1, \dots, i_l\}$  be a loop in  $G_c$ , which for now we will represent by just its subscripts  $\{1, \dots, l\}$  so that the notation is not too awkward. By definition, we have

$$f^{n(r)}(D_r), f(D_{r+1})|_{f^{n(r)}(C_r)} \text{ for } 1 \leq r \leq l$$

and by Proposition 5.30

$$\Psi^{n(r)}(A_i^c) \subset A_{r+1}(1)|_{f^{n(r)}(C_r)} \text{ for } 1 \leq r \leq l$$

from which it follows that

$$\Psi^{\sum_{r=1}^l n(r) - (l-2)}(A_1^c(1)) \subset A_1^c(1)|_{f^{\sum_{r=1}^l n(r) - (l-1)}(C_i)}$$

For a loop  $\mathcal{L} = \{i, \dots, i_l\}$  let  $n(\mathcal{L}) = \sum_{r=1}^l n(i_r) - (l-2)$ . By Lemma 4.7 and Corollary 4.8, there exists an isotopy  $h_{\mathcal{L}}$  of the identity with  $\text{supp } h_{\mathcal{L}} \subset I(A_{i_1}^c(1))$  such that, if  $\zeta_{\mathcal{L}}(\cdot) = h_{\mathcal{L}}(\cdot, 1)$ , then  $(\Psi \circ \zeta_{\mathcal{L}})^{kn(\mathcal{L})}(x) \rightarrow p$  for every  $x \in A_i^c(1)$ , where  $p$  is the fixed point of  $\Psi^{n(\mathcal{L})}$  in  $f^{n(\mathcal{L})+1}(C_i)$ . We then construct isotopies  $h_{\mathcal{L}}$  for each loop  $\mathcal{L}$  in  $G_c$ . Since the vertices of  $G_c$  where integers  $i \in \underline{L}$  for which  $n(i) > 1$ , the supports of isotopies associated to different loops are disjoint. Let  $h_c$  be the union of all these isotopies. By construction  $\text{supp } h_c \subset \bigcup_{i=1}^L I(A_i^c(1)) = \bigcup_{i=1}^L I^c(\alpha_i(1))$ .

In an analogous manner, we construct a directed graph  $G_e$  whose vertices are  $\{i \in \underline{L}; m(i) < 0\}$  and for each loop  $\mathcal{L}$  in  $G_e$ , we construct an isotopy  $h_{\mathcal{L}}$  of the identity, with support in  $A_{i_1}^e(1)$ , playing the analogous role for  $\Psi^{-1}$  as the above ones played for  $\Psi$ . Let  $k_e$  denote the union of these isotopies, for it is again easy to check that they have disjoint supports, and define  $h_e = \Psi^{-1} \circ k_e^{-1} \circ \Psi$ , i.e., for each fixed  $t$ ,  $h_e(x, t) = \Psi^{-1}(k_e^{-1}(\Psi(x), t))$ .  $h_e$  is also an isotopy of the identity and since  $\text{supp } k_e \subset \bigcup_{i=1}^L I(A_i^e(1))$ ,

$$\text{supp } h_e \subset \bigcup_{i=1}^L I(A_i^e(0)) = \bigcup_{i=1}^L I^e(\alpha_i(0)).$$

From this it follows that  $\text{supp } h_e \cap \text{supp } h_c = \emptyset$  and we let  $h = h_c \cup h_e$  and  $\zeta(\cdot) = h(\cdot, 1)$ . Finally set

$$H(x, t) = \begin{cases} h(x, 2t) & t \in \left[0, \frac{1}{2}\right] \\ R(\zeta(x), 2t - 1) & t \in \left[\frac{1}{2}, 1\right] \end{cases}.$$

It is now not hard to check that  $H$  has the desired properties.  $\square$

## 6 Examples

In this section we present examples of pruning collections for Smale's horseshoe map  $f : \mathbb{R}^2 \rightarrow \mathbb{R}^2$ . We begin by choosing a rigid model for  $f$  and describing some well known results, offered without proof. We also present some elementary concepts of kneading theory which we will need (the reader is referred to the books of Wiggins [Wi], Devaney [De], and de Melo and Van Strien [MS] for further details on the horseshoe and on 1-dimensional dynamics.) We then get to the examples. In describing the dynamics of the "pruned" maps  $f_P$  in each example, we will make several assertions and only sketch the proofs. The reason for proceeding thus is twofold. First, this is a section to give examples of pruning collections and this aspect is presented fully. Second, the details we omit are part of a more general theory deserving of separate treatment, which we intend to do in forthcoming papers.

We now fix a rigid model of Smale's horseshoe map  $f : \mathbb{R}^2 \rightarrow \mathbb{R}^2$ . Foliate the square

$$S = \{(x, y) : |x| \leq \frac{1}{2}, |y| \leq \frac{1}{2}\}$$

with horizontal *unstable* leaves and vertical *stable* leaves, and begin by choosing the action of  $f$  on  $S$  as depicted in figure 24. We require that  $f$  should stretch the unstable leaves uniformly, contract the stable leaves uniformly, and map segments of unstable (respectively, stable) leaf in  $S \cap f^{-1}(S)$  onto segments of unstable (respectively, stable) leaf in  $S$ . Moreover, we choose  $f$  to map the corner of  $S$  marked with a circle on figure 24 onto the corner of  $f(S)$  marked with a circle. Extend  $f$  to the half-disks  $A_1$  and  $A_2$  as depicted in the diagram: let  $f$  be a strict contraction of  $A_1 \cup A_2$ , so that there is a fixed point  $x$  of  $f$  lying in  $A_1$  with the property that  $f^i(y) \rightarrow x$  as  $i \rightarrow \infty$  for all  $y \in A_1 \cup A_2$ . Finally, extend  $f$  over the rest of  $\mathbb{R}^2$  without introducing any new nonwandering points.

The nonwandering set  $\Omega(f)$  of  $f$  consists of the fixed point  $\{x\}$  and an invariant Cantor set  $\Lambda \subset S$ . Moreover, there exists a homeomorphism  $h : \Sigma \rightarrow \Lambda$ , where  $\Sigma = \{0, 1\}^{\mathbb{Z}}$  is the two-sided

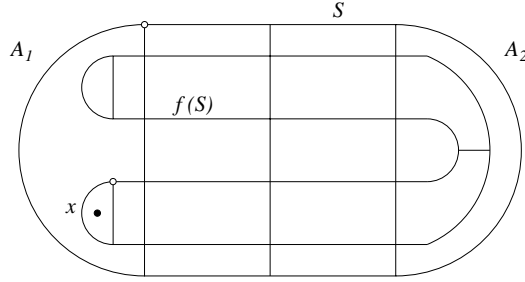

Figure 24: A rigid model for the horseshoe.

shift on two symbols, which conjugates the shift map  $\sigma : \Sigma \rightarrow \Sigma$  and  $f|_{\Lambda} : \Lambda \rightarrow \Lambda$ .  $\Lambda$  is a hyperbolic invariant set and each point  $p \in \Lambda$  has one-dimensional stable and unstable manifolds which intersect transversally. Notice that if two points  $p_0$  and  $p_1$  lie on the stable (unstable) manifold of some point  $q \in \Lambda$ ,  $p_0$  and  $p_1$  are the endpoints of exactly one arc contained in the stable (unstable) manifold of  $p$ .

We now describe the *unimodal order* on the one-sided shift space  $\Sigma_+ = \{0, 1\}^{\mathbb{N}}$  and, using it, define *kneading sequences*.

**Definition 6.1** Let  $s = s_0s_1\dots$  and  $t = t_0t_1\dots$  lie in  $\Sigma_+$  and suppose  $s_i = t_i$  for  $i < k$  and  $s_k \neq t_k$ . We set  $s \triangleleft t$  if  $\sum_{i=1}^k s_i$  is even. We set  $s \trianglelefteq t$  if either  $s = t$  or  $s \triangleleft t$ .

**Definition 6.2** Let  $\sigma : \Sigma_+ \rightarrow \Sigma_+$  be the shift map and  $\kappa \in \Sigma_+$ . We say  $\kappa$  is a *kneading sequence* if, for every  $n \in \mathbb{N}$ ,  $\sigma^n(\kappa) \trianglelefteq \kappa$ .

The unimodal order just defined is used in the study of 1-dimensional *unimodal* maps, i.e., piecewise monotone endomorphisms of the interval with exactly one critical (turning) point. In this context, kneading sequences are defined as the itinerary of the critical value. It is possible to check that kneading sequences associated to unimodal maps satisfy the definition above.

The unimodal order describes the horizontal and vertical ordering of points in  $\Lambda$  as follows: if  $(x_1, y_1), (x_2, y_2) \in \Lambda$ , with  $h(x_1, y_1) = s_{-2}s_{-1} \cdot s_0s_1\dots$  and  $h(x_2, y_2) = t_{-2}t_{-1} \cdot t_0t_1\dots$ , then

$$x_1 < x_2 \iff s_0s_1s_2 \cdots \triangleleft t_0t_1t_2 \cdots \quad \text{and}$$

$$y_1 < y_2 \iff s_{-1}s_{-2} \cdots \triangleleft t_{-1}t_{-2} \cdots$$

We shall often use the elements of  $\Sigma$  to describe points of  $\Lambda$  without explicitly invoking the map  $h$ . Thus, for example, we may talk about “the fixed point  $\bar{1}$ ,” “the periodic orbit  $\overline{10011}$ ,”

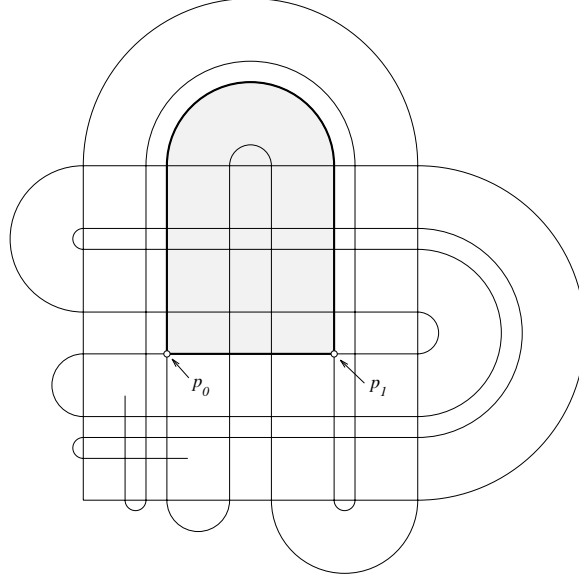

Figure 25:  $(c, e)$ -disk determined by  $p_0 = \overline{010.011\overline{0}}$  and  $p_1 = \overline{010.111\overline{0}}$

or “the point  $\overline{0.01\overline{01}}$ .” Here, a bar over a group of symbols stands for infinite repetition of the group. If the group is to the right (left) of the decimal point, it should be repeated infinitely to the right (left) and if there is no decimal point, the group should be repeated infinitely to both sides (so  $\overline{0.01\overline{01}} = \dots 000.0101101101\dots$  and  $\overline{10} = \dots 1010.1010\dots$ .) If the symbolic sequence is an element of  $\Sigma_+$ , a bar over a group of symbols means infinite repetition of the group to the right. Let  $p \in \Lambda$  and  $h(p) = s_{-2}s_{-1} \cdot s_0s_1\dots$ , we will sometimes refer to  $\dots s_{-2}s_{-1} \cdot s_0s_1\dots$  as the *symbolic representation* of  $p$  and to  $\dots s_{-2}s_{-1}$ . and  $.s_0s_1\dots$  as the *symbolic vertical and horizontal coordinates* of  $p$ , respectively.

If two points  $p_0, p_1 \in \Lambda$  have symbolic representation  $\dots t_{-2}t_{-1} \cdot t_0t_1\dots$  and  $\dots s_{-2}s_{-1} \cdot s_0s_1\dots$ , respectively,  $p_0$  and  $p_1$  lie on the same stable (unstable) manifold if there exists  $N \in \mathbb{Z}$  such that  $s_i = t_i$  for every  $i \geq N$  ( $i \leq N$ ). Consequently,  $p_0$  and  $p_1$  lie on the same stable *and* unstable manifolds if their symbolic representations differ in at most finitely many entries. If the symbolic representations of  $p_0$  and  $p_1$  differ at exactly one entry, the stable and unstable arcs of which they are the endpoints form a simple closed curve bounding a closed disk which we denote by  $D(p_0, p_1)$  (see figure 25.) Because the boundary of  $D(p_0, p_1)$  is the union of a stable and an unstable arcs,  $D(p_0, p_1)$  is a  $(c, e)$ -disk for  $f$  as defined in Section 3 whose vertices are  $p_0$  and  $p_1$ .

NOTATION: If  $p_0, p_1 \in \Lambda$  lie on the same stable (unstable) manifold, we denote the closed arc of stable (unstable) manifold whose endpoints are  $p_0$  and  $p_1$  by  $[p_0, p_1]_s$  ( $[p_0, p_1]_u$ ). Let  $s = s_0s_1\dots \in \Sigma_+$ . We define the *vertical segment with horizontal coordinate*  $s$  to be  $[\overline{0.s}, \overline{01.s}]_s$  and denote it

by  $\text{ver}(s)$ . A vertical segment is thus an arc of stable manifold extending from the lowest to the highest possible symbolic vertical coordinates (notice that  $000\dots$  and  $100\dots$  are, respectively, the smallest and largest elements of  $\Sigma_+$  in the unimodal order), having symbolic horizontal coordinate  $s$ . Notice also that, if we use  $\sigma$  to denote the shift map on  $\Sigma_+$ ,  $f(\text{ver}(s)) \subset \text{ver}(\sigma(s))$ .

We are now ready to present examples of pruning collections for  $f$ .

REMARK: So that the figures below are not hopelessly complicated and unintelligible, we will represent the Cantor set  $\Lambda$  as a solid square. Formally, what we are depicting is the quotient of  $\Lambda$  under an equivalence relation which collapses the “gaps” of the vertical and horizontal Cantor sets, the product of which is  $\Lambda$ . The ambiguity thus created is easily understood and the clarity gained plentifully compensates it.

**Example 1.** Let  $\kappa$  be a kneading sequence and

$$D = D(\bar{0}.0\kappa, \bar{0}.1\kappa)$$

be the  $(c, e)$ -disk determined by  $\bar{0}.0\kappa$  and  $\bar{0}.1\kappa$  (that is, the disk bounded by the union of  $C = [\bar{0}.0\kappa, \bar{0}.1\kappa]_s$  and  $E = [\bar{0}.0\kappa, \bar{0}.1\kappa]_u$ ). We claim that the collection  $\{D\}$ , containing  $D$  alone, is a pruning collection (see figure 26.) In order to see this we have to show that, if  $f^k(I) \cap I \neq \emptyset$  (where  $I$  is the interior of  $D$ ), then  $f^k(D) \succ D$ , if  $k > 0$ , and  $f^k(D) \prec D$ , if  $k < 0$ . Notice that conditions (ii) and (iii) in Definition 3.2 are automatically satisfied since  $C$  and  $E$  are arcs of stable and unstable manifolds which intersect transversally. All there is left to check is that  $f^n(C) \cap I = \emptyset$  for  $n > 0$  and  $f^m(E) \cap I = \emptyset$  for  $m < 0$ .

Notice that  $E \subset [\bar{0}, \bar{0}.1\bar{0}]_u$ , that

$$f^{-1}([\bar{0}, \bar{0}.1\bar{0}]_u) = [\bar{0}, \bar{0}.01\bar{0}]_u \subset [\bar{0}, \bar{0}.1\bar{0}]_u$$

and that

$$[\bar{0}, \bar{0}.1\bar{0}]_u \cap I = \emptyset .$$

Thus, if  $m \leq -1$ ,  $f^m(E) \cap I = \emptyset$ . On the other hand, observe that  $f(C) = \text{ver}(\kappa)$  and, therefore,  $f^n(C) \subset \text{ver}(\sigma^{n-1}(\kappa))$  for  $n \geq 1$ . If  $f^n(C) \cap I \neq \emptyset$ , then  $f^n(C) \subset I$  and, in fact,  $\text{ver}(\sigma^{n-1}(\kappa)) \subset I$ . This implies that

$$0\kappa \triangleleft \sigma^{n-1}(\kappa) \triangleleft 1\kappa$$

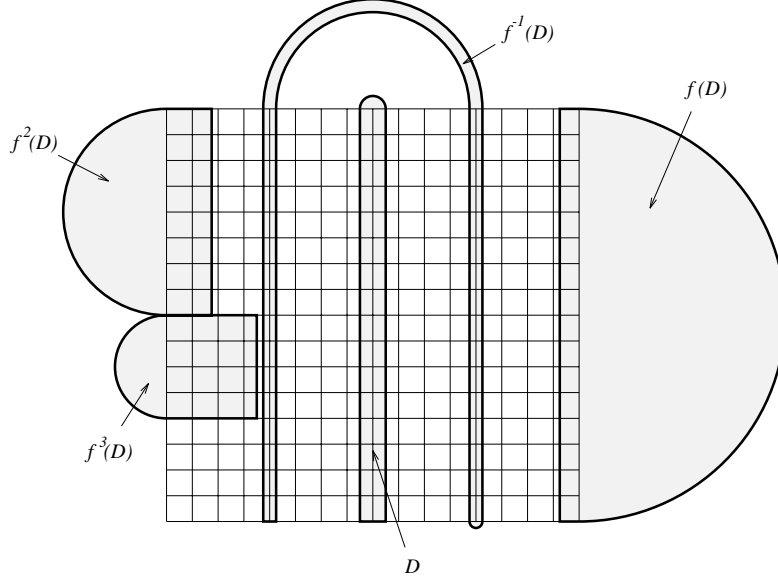

Figure 26: A “one-dimensional-like” pruning front for the horseshoe.

and, applying  $\sigma$  to this inequality, we get  $\kappa \triangleleft \sigma^n(\kappa)$ , which contradicts the assumption that  $\kappa$  is a kneading sequence.

Let  $f_\kappa$  denote the map obtained using Theorem 5.31 for  $\bar{P} = D$ . The family  $\mathcal{F} = \{f_\kappa; \kappa \text{ is a kneading sequence}\}$  mimics in dimension 2 a *full family* of unimodal maps of the interval. In particular,  $\mathcal{F}$  is an uncountable family of 2-dimensional homeomorphisms passing from trivial dynamics to a full horseshoe as  $\kappa$  varies from  $\bar{0}$  to  $\bar{10}$ .

**Example 2.** Consider the two  $(c, e)$ -disks

$$D_1 = D(\bar{1}.010\bar{1}, \bar{1}.110\bar{1}) \quad \text{and} \quad D_2 = D(\bar{1}01.0\bar{1}, \bar{1}01.\bar{1}) .$$

Because of the periodicity in the coordinates of the vertices of  $D_1$  and  $D_2$ , it is easy to check that  $\{D_1, D_2\}$  is a pruning collection (see figure 27.) Let  $\alpha_i(k) \subset f^k(D_i)$ , for  $i = 1, 2, k \in \mathbb{Z}$ , be closed cross-cuts as given by Proposition 3.18. Then

$$\gamma_0 = \bigcup \{\alpha_i(2k); i = 1, 2, k \in \mathbb{Z}\}$$

and

$$\gamma_1 = \bigcup \{\alpha_i(2k - 1); i = 1, 2, k \in \mathbb{Z}\}$$

are Jordan curves (see figure 28) such that  $\gamma_0 \cap \gamma_1 = \{\bar{1}\}$ . If  $f_P$  is the map given by Theorem 5.31 for the pruning front  $\bar{P} = D_1 \cup D_2$  and  $U_0$  and  $U_1$  are the closed disks bounded by  $\gamma_0$  and  $\gamma_1$ ,  $f_P$  interchanges  $U_0$  and  $U_1$ , that is,  $f_P(U_0) = U_1$  and  $f_P(U_1) = U_0$ . Moreover, if  $\Lambda_0 = \Omega(f_P) \cap U_0$  is the



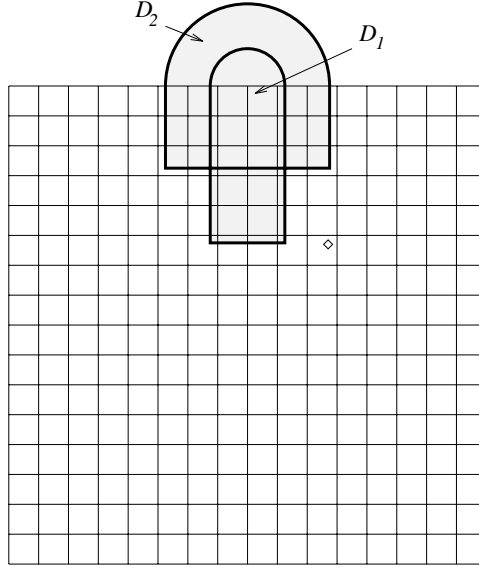

Figure 27: The  $(c, e)$ -disks  $D_1$  and  $D_2$  of Example 2.  $\diamond$  is the fixed point  $\bar{1}$ .

intersection of the nonwandering set of  $f_P$  with  $U_0$ ,  $f_P^2|_{\Lambda_0} : \Lambda_0 \rightarrow \Lambda_0$  is topologically conjugated to the full horseshoe  $f|_{\Lambda} : \Lambda \rightarrow \Lambda$  restricted to the set  $\Lambda$ . This is an example of a “renormalizable” or “reducible” map.

**Example 3.** Consider the  $(c, e)$ -disks

$$D_1 = D(\bar{0}.0\overline{1000100}, \bar{0}.1\overline{1000100}) \quad \text{and} \quad D_2 = D(\bar{0}1100010.\bar{0}\bar{1}, \bar{0}1100010.\bar{1}) .$$

Notice that  $D_1$  is of the kind  $D(\bar{0}.0\kappa, \bar{0}.1\kappa)$ , since  $\kappa = \overline{1000100} \in \Sigma_+$  is a kneading sequence, as may easily be verified. As in the previous example, the periodicity in the coordinates of the vertices of  $D_1$  and  $D_2$  make it an easy computation to check that  $\{D_1, D_2\}$  is a pruning collection (see figure 29.)

Let  $s_7^6(0)$  denote the periodic orbit containing the point  $\overline{1000100}$  (see [HWh] for an explanation of this name). Since none of its seven points lies in  $P = I_1 \cup I_2$ , none of them lies in  $\bigcup_{n \in \mathbb{Z}} f^n(P)$ . In figure 30,  $f^k(P)$ , for  $-1 \leq k \leq 3$ , are shown. Notice that the nonwandering points of  $f_P$  lie outside the shaded region. (In fact, it is not hard to see that the points on the open  $e$ -side  $\overset{\circ}{E}_1$  of  $D_1$  are also wandering under  $f_P$ .)

We claim that the map  $f_P$  obtained using Theorem 5.31 realizes the minimum topological entropy among all maps in the isotopy class of  $f$  relative to  $s_7^6(0)$ . In order to see this, we construct a Markov Partition for  $f_P$  like in figure 31. The horizontal and vertical sides of the rectangles  $R_i$  are contained in  $\bigcup_{n \in \mathbb{Z}} f_P^n(E_1 \cup E_2)$  and  $\bigcup_{n \in \mathbb{Z}} f_P^n(C_1 \cup C_2)$ , respectively. (In fact, it is enough to take the

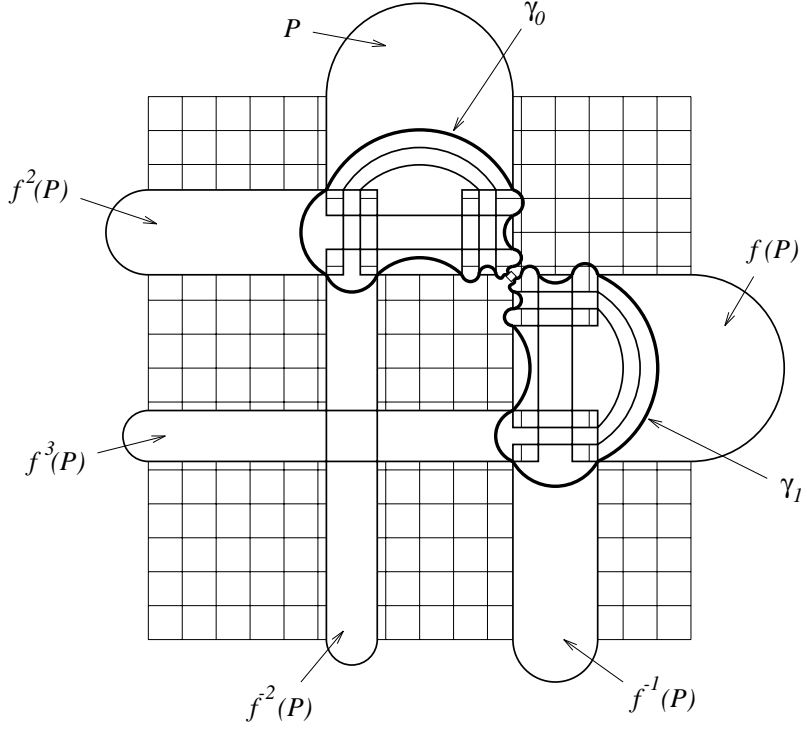

Figure 28: The Jordan curves  $\gamma_0$  and  $\gamma_1$

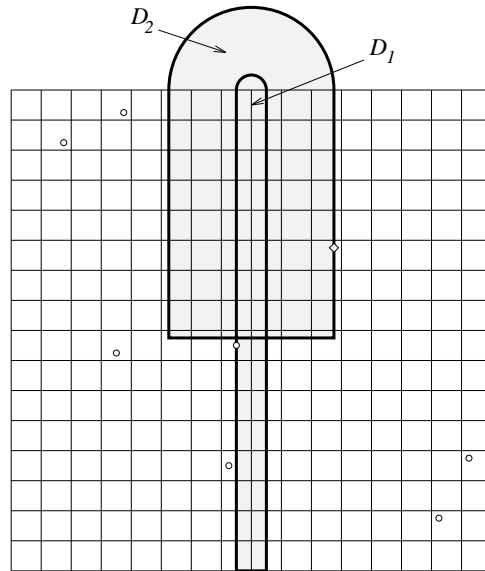

Figure 29: The  $(c, e)$ -disks  $D_1$  and  $D_2$  of Example 3. The points marked by  $\circ$  are the periodic orbit  $s_7^6(0)$  and  $\diamond$  is the fixed point  $\bar{1}$ .

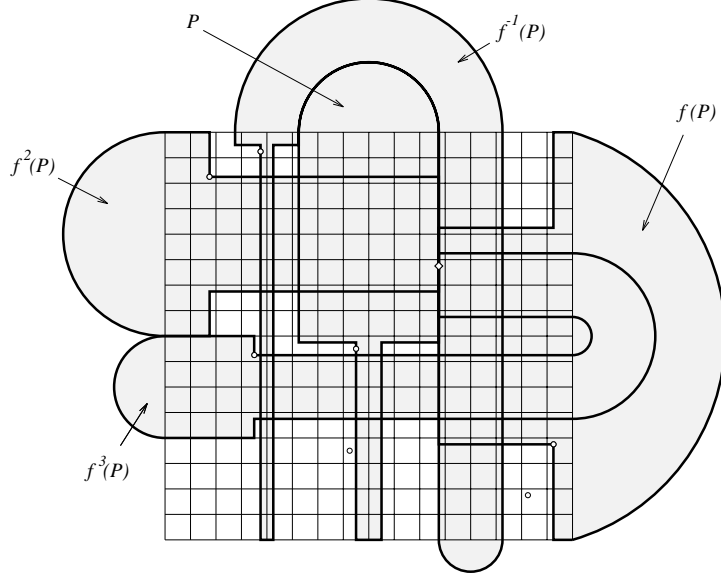

Figure 30: A few images of  $P$  under  $f$ .

unions ranging from  $n = -7$  to  $n = 7$ , say.) It is easy to see that, if we define  $\Lambda_P = \Omega(f_P) \setminus \{\bar{0}, \bar{1}\}$ , where  $\Omega(f_P)$  is the nonwandering set of  $f_P$  and  $\bar{0}$  and  $\bar{1}$  are the fixed of  $f$  inside  $S$ , which are also fixed points under  $f_P$ , then  $\Lambda_P \subset \bigcup_{i=1}^8 R_i$ . The vertices of each  $R_i$  lie outside of  $\bigcup_{n \in \mathbb{Z}} f^n(P)$  and it therefore makes sense to refer to them using their symbolic representation in  $\Sigma$ . In table 1 we give the symbolic horizontal and vertical coordinates of the vertices of the rectangle  $R_i$ . The columns under  $x_L$  and  $x_R$  contain the left and right horizontal coordinates, respectively, whereas those under  $y_L$  and  $y_U$  contain the lower and upper vertical coordinates, respectively.

In figure 32 we show how the rectangles  $R_i$  are mapped under  $f_P$ . The transition matrix  $M = (m_{ij})$  associated with this partition is the  $8 \times 8$  matrix defined by

$$m_{ij} = \begin{cases} 1, & \text{if } I(f_P(R_j)) \cap R_i \neq \emptyset \\ 0, & \text{otherwise} \end{cases}$$

where  $I(R_i)$  stands for the interior of the rectangle  $R_i$ . Using the notation  $R_j \rightarrow R_i$  for  $I(f_P(R_j)) \cap R_i \neq \emptyset$ , we have  $R_1 \rightarrow R_2 R_3 R_4$ ,  $R_2 \rightarrow R_5$ ,  $R_3 \rightarrow R_6$ ,  $R_4 \rightarrow R_7$ ,  $R_5 \rightarrow R_8$ ,  $R_6 \rightarrow R_8 R_7$ ,  $R_7 \rightarrow R_3$ ,  $R_8 \rightarrow R_2 R_1$ , so that

$$M = \begin{bmatrix} 0 & 0 & 0 & 0 & 0 & 0 & 0 & 1 \\ 1 & 0 & 0 & 0 & 0 & 0 & 0 & 1 \\ 1 & 0 & 0 & 0 & 0 & 0 & 1 & 0 \\ 1 & 0 & 0 & 0 & 0 & 0 & 0 & 0 \\ 0 & 1 & 0 & 0 & 0 & 0 & 0 & 0 \\ 0 & 0 & 1 & 0 & 0 & 0 & 0 & 0 \\ 0 & 0 & 0 & 1 & 0 & 1 & 0 & 0 \\ 0 & 0 & 0 & 0 & 1 & 1 & 0 & 0 \end{bmatrix}$$

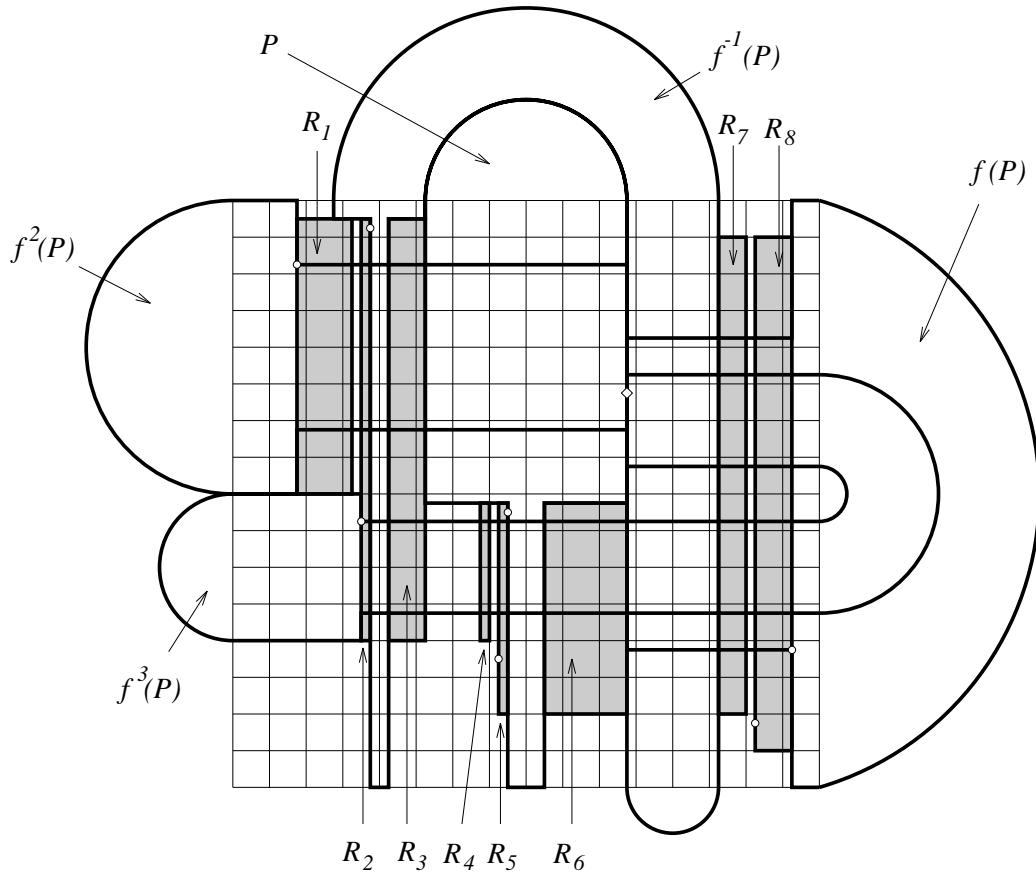

Figure 31: The Markov Partition for  $f_P$ .

	$x_L$	$x_R$	$y_L$	$y_U$
$R_1$	$\overline{.0001001}$	$\overline{.001011\overline{1000100}}$	$\overline{0}11.$	$\overline{0}110001.$
$R_2$	$\overline{.0010010}$	$\overline{.0010001}$	$\overline{0}110.$	$\overline{0}110001.$
$R_3$	$\overline{.011000100}$	$\overline{.0\overline{1}}$	$\overline{0}110.$	$\overline{0}110001.$
$R_4$	$\overline{.010\overline{1}}$	$\overline{.01011\overline{1000100}}$	$\overline{0}110.$	$\overline{0}1100010.$
$R_5$	$\overline{.0100100}$	$\overline{.0100010}$	$\overline{0}1100.$	$\overline{0}1100010.$
$R_6$	$\overline{.11000100}$	$\overline{.1}$	$\overline{0}1100.$	$\overline{0}1100010.$
$R_7$	$\overline{.10\overline{1}}$	$\overline{.1011\overline{1000100}}$	$\overline{0}1100.$	$\overline{0}11001.$
$R_8$	$\overline{.1001000}$	$\overline{.1000100}$	$\overline{0}11000.$	$\overline{0}11001.$

Table 1: The coordinates of the vertices of the rectangles  $R_i$ .

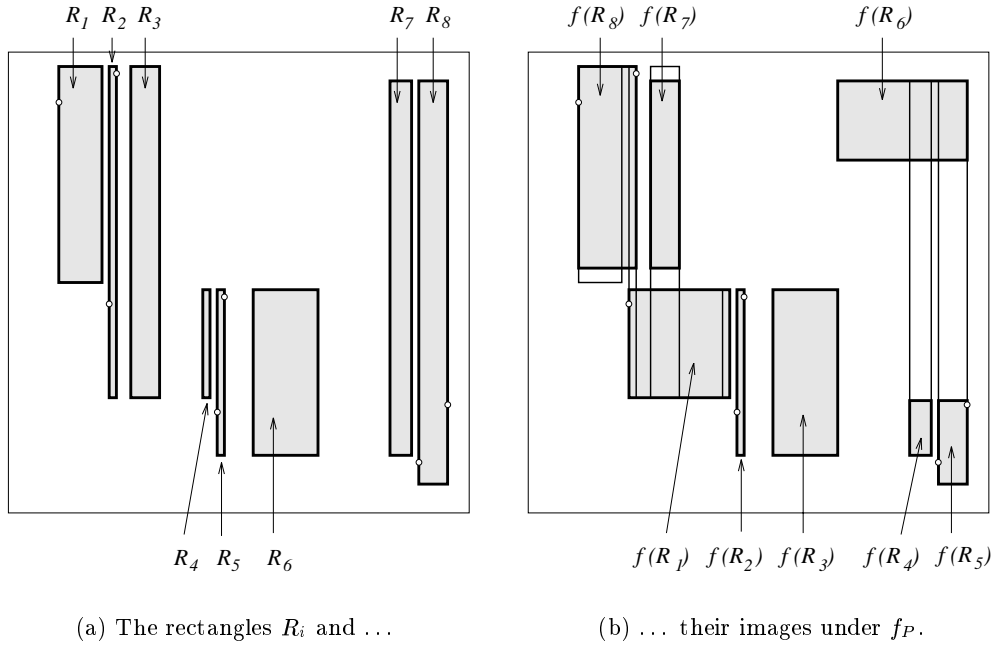

Figure 32: The Markov Partition and its image.

Let

$$\Sigma_M = \{s = \dots s_{-2}s_{-1} \cdot s_0s_1 \dots \in \{0, 1, \dots, 8\}^{\mathbb{Z}}; m_{s_i s_{i+1}} = 1 \forall i \in \mathbb{Z}\}$$

be the subshift of finite type associated to  $M$ . It is possible to show that, if  $s = \dots s_{-2}s_{-1} \cdot s_0s_1 \dots \in \Sigma_M$ , then  $\bigcap_{n \in \mathbb{Z}} f_P^{-n}(R_{s_n})$  consists of a single point in  $\Lambda_P$  and that the map  $k : \Sigma_M \rightarrow \Lambda_P$ , given by  $k(s) = \bigcap_{n \in \mathbb{Z}} f_P^{-n}(R_{s_n})$ , is a topological conjugacy between the shift map  $\sigma : \Sigma_M \rightarrow \Sigma_M$  and  $f_P|_{\Lambda_P} : \Lambda_P \rightarrow \Lambda_P$ . Under these circumstances,  $h(f_P) = \log \lambda$ , where  $\lambda$  is the spectral radius of  $M$ . Using your favorite matrix computation program, you may check that  $\lambda = 1.46557$  and that  $\log \lambda = 0.382244$ , which agrees with table 1 of [H2]. Although this is not a proof, one may be obtained using the algorithm in [BH] to find the pseudo-Anosov homeomorphism in the isotopy class of  $f$  rel.  $s_7^6(0)$ . It is known that this map realizes the minimum topological entropy in its isotopy class and it is possible to find a Markov Partition for it with the same transition matrix  $M$ .

As was mentioned in the introduction, we intend to show in a forthcoming paper that, as in Example 3, given a horseshoe periodic orbit collection  $\mathcal{O}$ , there exists a pruning front  $P = P(\mathcal{O})$  such that  $f_P$  restricted to  $\Omega(f_P)$  is semiconjugated to the Thurston minimal representative  $\phi_{\mathcal{O}}$  in the isotopy class of  $f$  rel.  $\mathcal{O}$  and that  $h(f_P) = h(\phi_{\mathcal{O}})$ .

## References

- [BH] Bestvina, M. and Handel, M. *Train-tracks for surface homeomorphisms*, Topology Vol. 34, No. 1, 1995, pp. 109–140.
- [C] Cvitanović, P., Gunaratne, G., and Procaccia, I., *Topological and Metric Properties of Hénon-type Strange Attractors*, Physical Review A Vol. 38, No. 3, 1988, pp. 1503–1520.
- [MS] de Melo, W. and van Strien, S. *One-dimensional Dynamics*, (Springer-Verlag, 1993.)
- [De] Devaney, R. *An Introduction to Chaotic Dynamical Systems*, (Benjamin/Cummings, 1986.)
- [H] Hall, T., *Periodicity in Chaos: the Dynamics of Surface Automorphisms*, Thesis (Cambridge, 1991.)
- [H2] Hall, T. *The creation of horseshoes*, Nonlinearity 7, 1994, pp. 861–924.
- [HWh] Holmes, P. and Whitley, D. *Bifurcation of one- and two-dimensional mappings*, Phil. Trans. R. Soc. Ser. A 311, 1984, pp. 43–102.
- [M] Moise, E.E., *Geometric Topology in Dimensions 2 and 3*, Graduate Texts in Mathematics, (Springer-Verlag, 1977.)
- [Mo] Moore, R.L., *Foundations of Point Set Theory*, Colloquium Publications Vol. 13 (American Mathematical Society, 1932; reprinted 1987.)
- [Ne] Newman, M.H.A., *Elements of the Topology of Plane Sets of Points*, (Cambridge University Press, 1961.)
- [Wi] Wiggins, S. *Introduction to Applied Nonlinear Dynamical Systems and Chaos*, Texts in Applied Mathematics, (Springer-Verlag, 1990.)
- [Wh] Whyburn, G.T., *Analytic Topology*, Colloquium Publications Vol. 28 (American Mathematical Society, 1942; reprinted 1971.)